



HAND-**E**

Original Notice

© 2022 Robotiq, Inc.

Robotiq Hand-E
for Cobots



Instruction Manual

LEAN 
ROBOTICS

robotiq.com | leanrobotics.org

Revisions	4
1. General Presentation	6
1.1. Gripper nomenclature	7
1.2. Object picking	9
1.3. Setup and control	10
2. Safety	11
2.1. Warning	12
2.2. Intended Use	12
3. Installation	13
3.1. Scope of Delivery	14
3.2. Required Tools and Equipment	15
3.3. Environmental and Operating Conditions	16
3.4. Mechanical Installation	17
3.5. Electrical Setup	21
4. Control	23
4.1. Overview	23
4.2. Gripper Register Mapping	25
4.3. Robot Output Registers & Functionalities	26
4.4. Robot Input Registers and Status	28
4.5. Picking Features	32
4.6. Control Logic Example	35
4.7. Modbus RTU Communication	35
5. Specifications	49
5.1. Technical dimensions	50
5.2. Mechanical Specifications	63
5.3. Electrical specifications	69
6. Maintenance	70
6.1. Gripper cleaning	72
6.2. Periodic inspection	73
6.3. Rack & pinion mechanism cleaning	74
7. Spare Parts, Kits and Accessories	76



8. Troubleshooting	80
8.1. Using the Robotiq User Interface (RUI)	80
9. Warranty and Patent	81
10. Harmonized Standards, Declarations and Certificates	84
10.1. EC declaration of incorporation	84
10.2. Applied standards	85
10.3. Ingress Protection Certificate	86
11. Contact	87



Revisions

Robotiq may modify this product without notice, when necessary, due to product improvements, modifications or changes in specifications. If such modification is made, the manual will also be revised, see revision information. See the latest version of this manual online at robotiq.com/support.

Revision 2022/01/10

- Part number updated in the Scope of Delivery section

Revision 2021/07/01

- Section " Installation"
 - Added section 3.4.4 " Installing Fingertip Extenders on the Gripper"
 - Updated subsection 3.4.1 " Single Gripper Installation"
- Section " Specifications"
 - Updated subsection 5.1.3 " Fingertips Extenders" , maximum opening is now 98 mm
 - Updated section 5.2.1
 - Updated section 5.2.3
- Section " Spare Parts, Kits and Accessories"
 - Hand-E SKU is now HND-GRP

Revision 2020/05/28

- Minor Revision: modifications to standardize our manuals
- Section " Warranty and Patent"
 - Cycle count is now 5 000 000.
 - Consumable parts are now excluded of the warranty.
- Section " Specifications"
 - Updated subsection " Mechanical Specifications"
 - Updated subsection " Electrical Specifications"
 - Updated subsection " Technical Dimensions"
- Section " Harmonized Standards, Declarations and Certificates"
 - Updated subsection " EC declaration of incorporation"
 - Updated subsection " Applied Standards"

Revision 2019/12/19

- Official release



Copyright

© 2019 - 2022 Robotiq Inc. All rights reserved.

This manual and the product it describes are protected by the Copyright Act of Canada, by laws of other countries, and by international treaties, and therefore may not be reproduced in whole or in part, whether for sale or not, without prior written consent from Robotiq. Under copyright law, copying includes translation into another language or format.

Information provided by Robotiq in this document is believed to be accurate and reliable. However, no responsibility is assumed by Robotiq for its use. There may be some differences between the manual and the product if the product has been modified after the edition date.

The information contained in this document is subject to change without notice.



1. General Presentation

The terms "Gripper", "Robotiq Gripper", "Hand-E Gripper" and "Hand-E" used in this manual are used interchangeably to designate the "Robotiq Hand-E Gripper". The Robotiq Hand-E Gripper is a robotic peripheral designed for industrial applications. It is a unique robotic end-of-arm tool designed to quickly pick, place and handle parts in a broad range of sizes and shapes.

Info

This manual uses the metric system. Unless otherwise specified, **all dimensions are in millimeters**.

Info

The following section presents the key features of the Gripper and must not be considered as appropriate to Gripper operation, each feature is detailed in the appropriate section of the manual. Safety guidelines must be read and understood before any operation is attempted with the Gripper.



1.1. Gripper nomenclature

The Hand-E Gripper is a parallel gripper. Its two fingers are actuated by a single motor.



Fig. 1-1: Robotiq Hand-E Gripper.

Please refer to the **Scope of Delivery** section and **Spare Parts, Kits and Accessories** section for details on standard and optional parts. The Hand-E basic gripper unit includes flat aluminum fingers overmolded with NBR.

The status LED presented in the figure above will be :

- solid blue/red when booting
- solid blue when powered with no errors (while communication is active)
- solid red if minor fault occurs, see status details in the **Control** section.
- blinking red/blue if major fault occurs, see status details in the **Control** section.

The user can install fingers directly on the racks, or fasten fingertips to fingertip holders, which are in turn installed on the racks. Refer to the **Installing the Gripper on the Robot** section for more information on how to integrate custom fingers and fingertips to Hand-E.

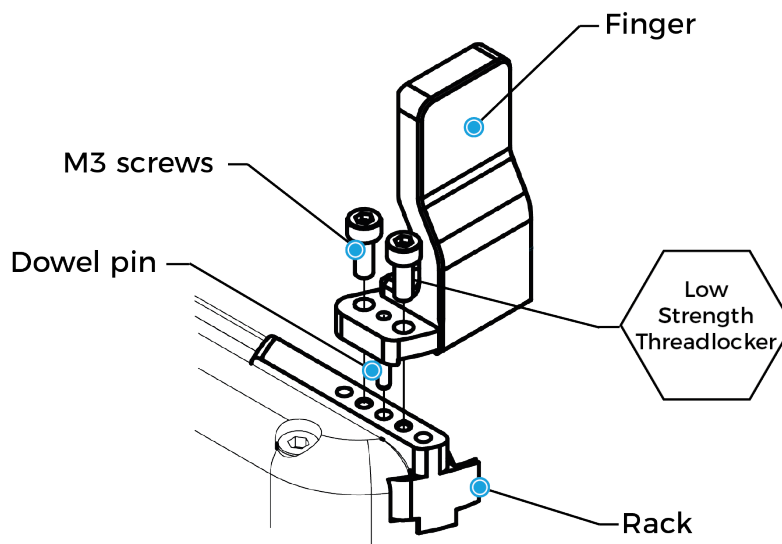

Fig. 1-2: Mounting a finger on a rack.

When ordered as a kit (please refer to the **Scope of Delivery** section), a fingertip starting kit is included (please refer to the **Spare Parts, Kits and Accessories** section). These fingertips should be mounted onto fingertip holders.

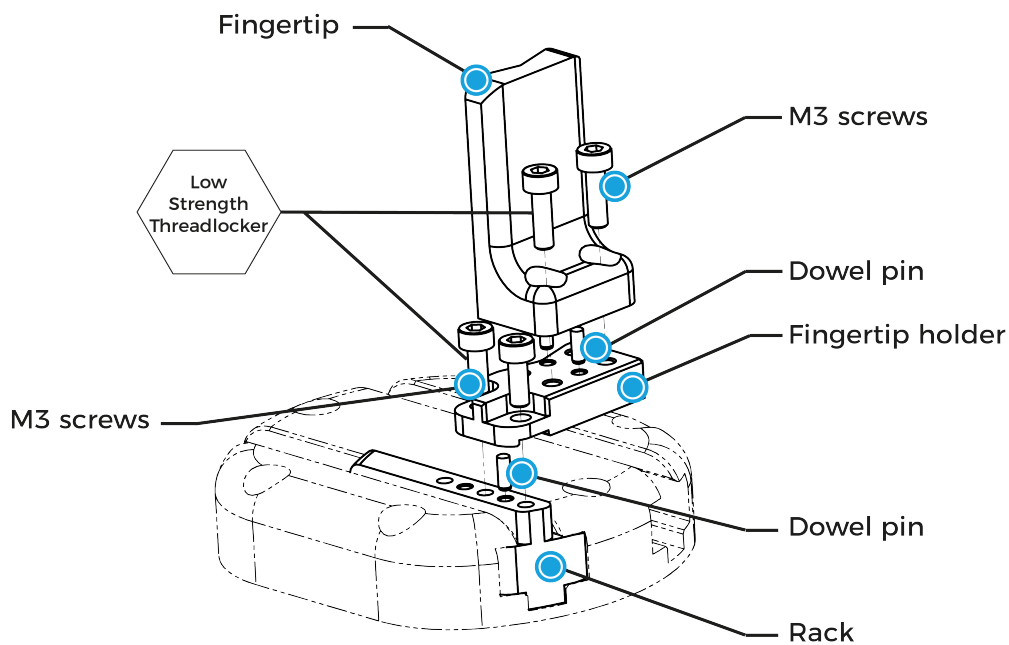

Fig. 1-3: Mounting a fingertip on a fingertip holder (example).

Tip

You can customize fingers and fingertips. Mount custom fingers on racks, and fingertips on fingertip holders.



12. Object picking

The Hand-E Gripper has a single actuator for opening and closing the fingers. It also allows internal gripping. The fingers can pick hollow parts from the inside by applying pressure with the outer surface of the fingers.

See the figure below for a representation and refer to the **Picking Features** section for details on available position commands for your gripper.

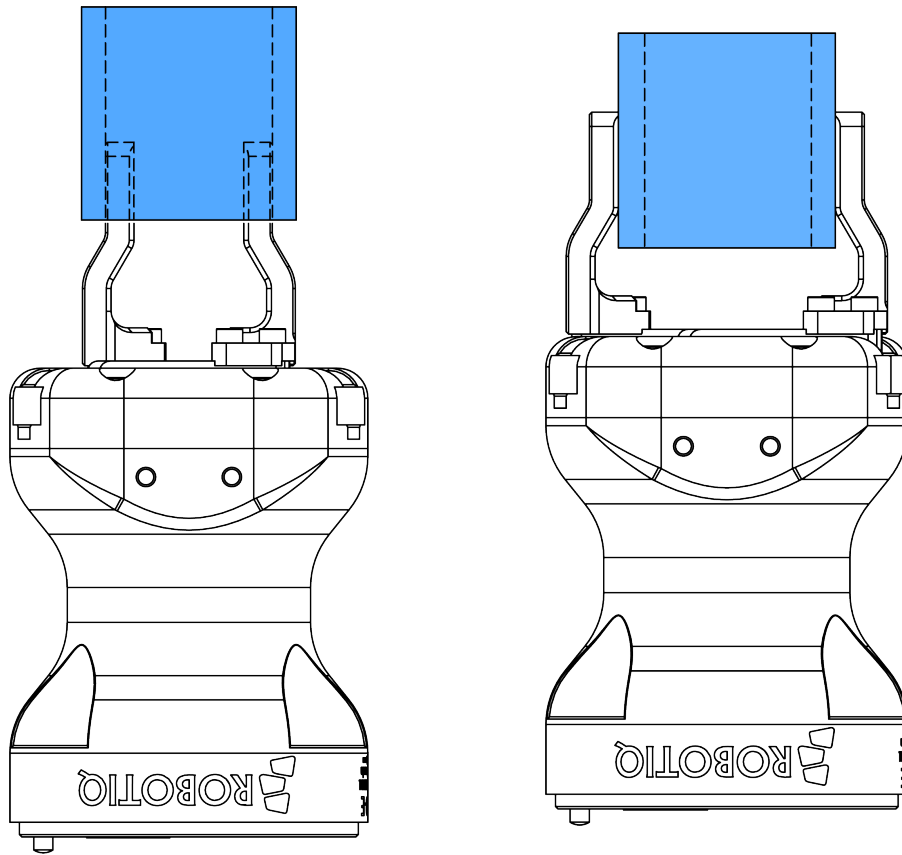

Fig. 1-4: Hand-E Gripper internal and external gripping.

1.3. Setup and control

The Gripper is powered and controlled directly via a single device cable that carries a 24V DC supply and Modbus RTU communication over RS-485. Refer to the **Electrical Setup** section for wiring information and the **Control** section for control of the gripper (software packages are available for control via some types of robot controllers).

Info

Robotiq Universal Controller is available when industrial communication protocols are required (other than Modbus RTU over serial).

A gripper coupling is required for using Hand-E; the coupling will provide mechanical and electrical connectivity. Please refer to the **Mechanical Installation** section for installation of the coupling, to the **Specifications** section for technical drawings, and to the **Spare Parts, Kits and Accessories** section for available couplings.

The Hand-E Gripper has an embedded object detection feature using indirect sensing methods. When picking an object with the "go to" command, the gripper status will allow you to know if an object is picked or not via a simple object detection bit (0 or 1). When an object is detected, the gripper will stop. If the object is being dropped, the gripper will automatically close to keep the object until the object is detected or until the position target from the "go to" command is reached. For details on object detection, see the **Control** section.



2. Safety

Warning

The operator must have read and understood all of the instructions in the following manual before handling the Robotiq Hand-E Gripper.

Info

The term "operator" refers to anyone responsible for any of the following operations on the Robotiq Hand-E Gripper:

- Installation
- Control
- Maintenance
- Inspection
- Calibration
- Programming
- Decommissioning

This documentation explains the various components of the Robotiq Hand-E Gripper and general operations regarding the whole life-cycle of the product from installation to operation and decommissioning.

The drawings and photos in this documentation are representative examples; nonetheless, discrepancies may be observed between those and the delivered product.



2.1. Warning

Caution

Any use of the Gripper in noncompliance of these warnings is inappropriate and may cause injury or damage.

Warning

- The Gripper needs to be properly secured before operating the robot.
- Do not install or operate a Gripper that is damaged or lacking parts.
- Never supply the Gripper with an alternative current source.
- Make sure all cord sets are always secured at both ends, at the Gripper and at the robot.
- Always meet the recommended keying for electrical connections.
- Make sure no one is in the robot and/or Gripper path before initializing the robot's routine.
- Always meet the Gripper's payload specifications.
- Set the Gripper's pinch force and speed accordingly, based on your application.
- Keep fingers and clothes away from the Gripper while the power is on.
- Do not use the Gripper on people or animals.
- For welding applications, make sure there are no Gripper parts on the ground path of the welding power source.

2.1.1. Risk assessment and final application:

The Robotiq Hand-E Gripper is meant to be used on an industrial robot. The robot, Gripper and any other equipment used in the final application must be evaluated with a risk assessment. It is the robot integrator's duty to ensure that all local safety measures and regulations are met. Depending on the application, there may be risks that require additional protection/safety measures, for example, the work-piece the gripper is manipulating might be inherently dangerous to the operator.

2.2. Intended Use

The gripper unit is designed for gripping and temporarily securing or holding objects.

The product is intended for installation on a robot or other automated machinery and equipment.

Info

Always comply with local and/or national laws, regulations and directives on automation safety and general machine safety.

The unit should be used exclusively within the range of its technical data. Any other use of the product is deemed improper and unintended use. Robotiq will not be liable for any damages resulting from any improper or unintended use.



3. Installation

The following subsections will guide you through the installation and general setup of your Robotiq Hand-E Gripper.

- The **Scope of Delivery** section
- The **Required Tools and Equipment** section
- The **Environmental and Operating Conditions** section
- The **Mechanical Installation** section
- The **Electrical Setup** section
- The **Installation** section

Warning

Before installing:

- Read and understand the safety instructions related to the Hand-E Gripper.
- Verify your package according to the scope of delivery and your order.
- Have the required parts, equipment and tools listed in the requirements readily available.

Warning

When installing:

- Meet the recommended environmental conditions.
- Do not operate the Gripper, or even turn on the power supply, before it is firmly anchored and the danger zone is cleared. The fingers of the gripper may move and cause injury or damage.



3.1. Scope of Delivery

Caution

The following is not included as part of a standard delivery:

- Options such as adapter plates or couplings for mounting on various industrial robots, fingertips or finger pads.
- Hardware required for options; accessories or fixtures for the gripper, unless specified.
- Power supply units, power supply wiring or fuses.

3.1.1. Robotiq Hand-E Gripper

Standard upon delivery

- Robotiq Hand-E basic gripper unit (**HND-GRP**)
- Hand-E Fingertip Starting Kit (**HND-TIP-START-KIT**)
- USB to RS485 signal converter (**ACC-ADT-USB-RS485**)
- Coupling for connection to the robot controller (**GRP-CPL-062**)

Info

See the **Spare Parts, Kits and Accessories** section section for a list of available couplings.

- Robotiq device cable (**CBL-COM-2065-10-HF**)

Optional:

- RS485 to RS232 signal converter (**ACC-ADT-RS232-RS485**)
- Robotiq Universal Controller (**UNI-CTR-XXXX**)



3.2. Required Tools and Equipment

The following tools are required to install the Hand-E Gripper:

- 4 mm hex key to mount the gripper onto its coupling .
- Metric hex key according to your coupling to mount the coupling onto the robot.

Optional tools if installing fingertip/holder kits: **HND-FIN-ALU-KIT**, **HND-TIP-VGR-KIT** or **HND-TIP-HLD-KIT**

- 2,5 mm hex key

The following parts are required for setup :

- Power supply (see below).
- Fuse, see information below.
- Emergency stop is not provided, but its use is strongly advised.

The gripper needs to be supplied by a DC voltage source. This power supply is not included with the gripper. Required power supply must match the Robotiq device. The following table shows the specifications with regards to the power supply required to operate the gripper and the optional Robotiq Controller.

SPECIFICATION	VALUE
Output voltage	24 V DC \pm 10%
Output current	1 A
Overcurrent	Recommended power supply with internal protection, otherwise fusing is required. 2 A fuse at 25°C [77°F] ¹

Table 3-1: Hand-E power supply requirements.

Info

¹ Suggested fuse is a: Phoenix Contact # 0916605 2 A thermal, use AWG #20 wiring.

Warning

If your power supply could exceed the specified regulation, over-voltage protection is required.

Robotiq recommends the use of the following power supplies:

- For the 1A output current: TDK-Lambda DPP Series, *100W Single Output DIN Rail Mount Power Supply*. **DPP30-24**.

Tip

Optional Robotiq Universal Controller can use the same power supply.



3.3. Environmental and Operating Conditions

CONDITION	VALUE
Minimum storage temperature	-30°C [-22°F]
Maximum storage temperature	70°C [158°F]
Minimum operating temperature	-10°C [14°F]
Maximum operating temperature	50°C [122°F]
Humidity (non-condensing)	20-80% RH
Maximum vibration (storage/transit)	5G
Maximum vibration (operating)	2G
IP Rating	IP 67
Other	<ul style="list-style-type: none"> • Free from corrosive liquids or gases • Free from explosive liquids or gases • Free from powerful electromagnetic interference

Table 3-2: Environmental and operating conditions of the Hand-E Gripper.



3.4. Mechanical Installation

3.4.1. Installing the Gripper on the Robot

Single Gripper Installation

Instructions

You must use a coupling to attach the gripper on the robot. Here are the steps to follow to mount the gripper on the robot (exploded views in the figure below).

1. If required, install the adapter plate on the robot tool flange.
2. Secure the gripper coupling on the robot wrist, and use the coupling dowel pin to align parts.
3. Secure the gripper to the coupling.

Caution

When no tooth lock washer is present, lock screws in place using medium strength threadlocker. Tooth lock washers provide grounding for the casing of the gripper through the mounting screws. For more information, refer to the **Electrostatic Discharge Safety** section.

Grippers are secured to robots via a coupling designed for specific robot models. If no such coupling exists, you can machine a blank coupling on your own or Robotiq can support you in designing this custom coupling. Some couplings may require an additional adapter plate. To machine a custom coupling or adapter plate, see the **Couplings** section. For details on available couplings and adapter plates, see the **Spare Parts, Kits and Accessories** section.



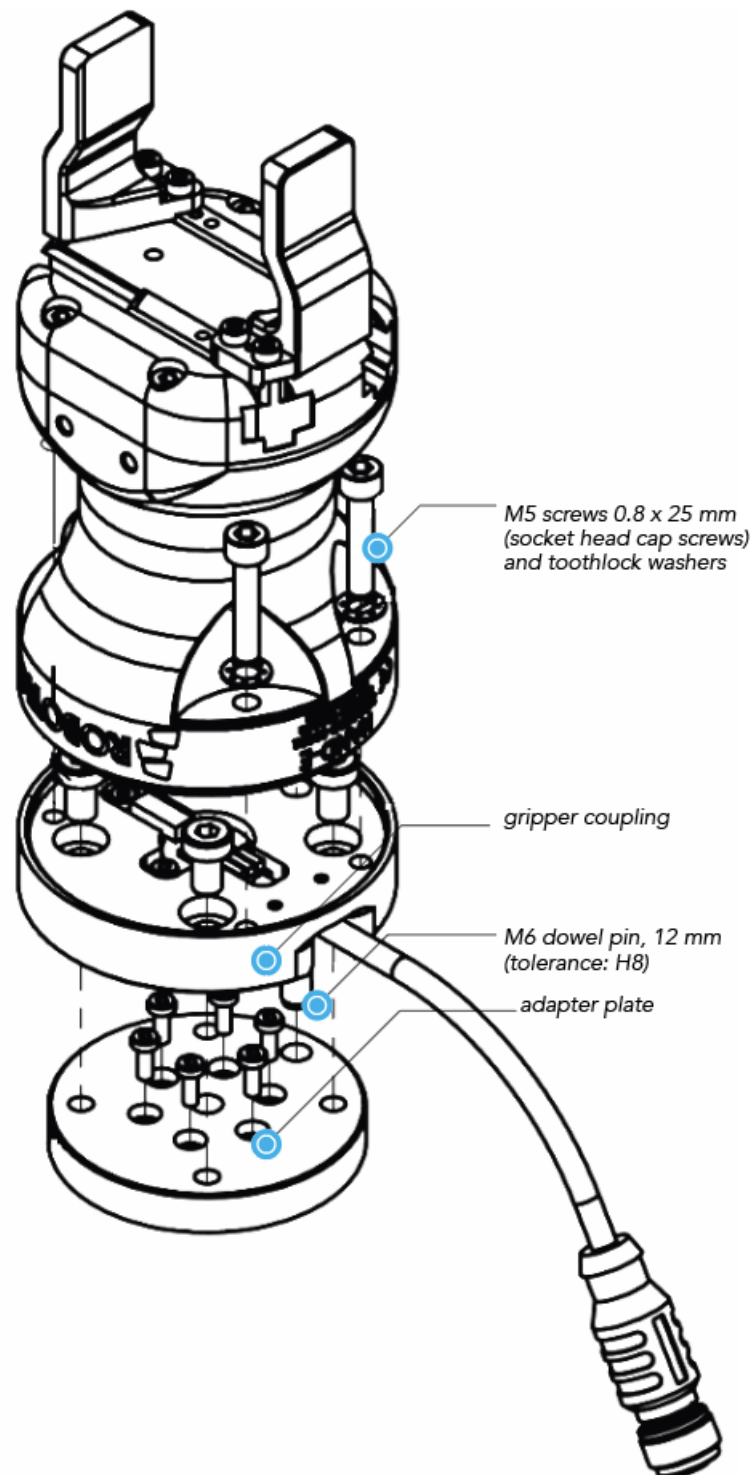

Fig. 3-1: Mounting Hand-E with a coupling and an adapter plate, on a robot tool flange.

Info

The coupling used in the figure above is used for reference only and corresponds to bolt pattern ISO 9409-1-50-4-M6.

3.4.2. Installing Fingers on the Gripper

If you need to change the fingers, follow the instructions below.

1. Align the finger dowel pin with the finger dowel hole.
2. Apply low strength threadlocker on the provided screws and secure the finger to the rack.
3. Repeat for the second finger, if necessary.

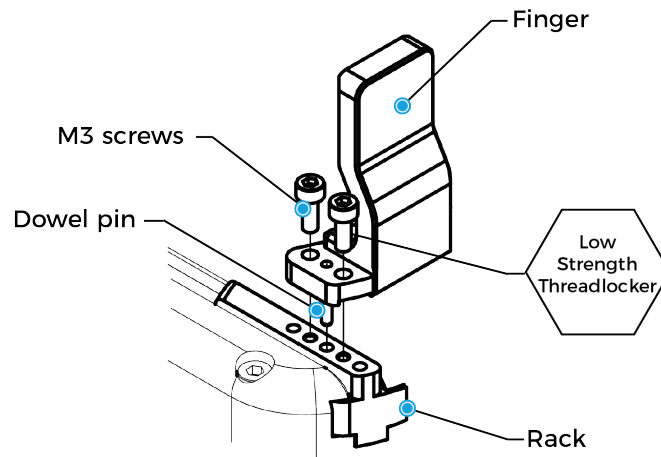

Fig. 3-2: Mounting fingers on racks.

3.4.3. Installing Fingertips and Holders on the Gripper

If you need to change the fingertips and holders, follow the instructions below.

1. Align the fingertip holder dowel pin with the rack dowel hole.
2. Apply low strength threadlocker on the provided screws and secure the fingertip holder to the rack.
3. Align the fingertip dowel pin with the fingertip holder dowel hole.
4. Apply low strength threadlocker on the provided screws and secure the fingertip to the fingertip holder.
5. Repeat for the second fingertip, if necessary.

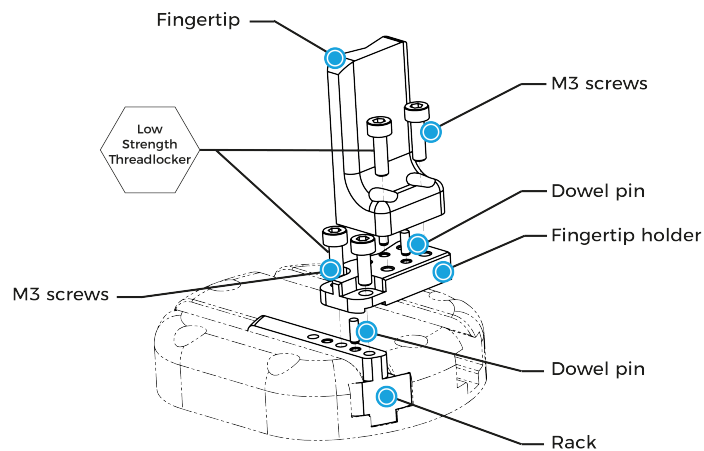

Fig. 3-3: Mounting fingertips on holders, and holders on racks.



3.4.4. Installing Fingertip Extenders on the Gripper

If you need to add extenders to the Gripper, follow the instructions below.

1. Align the extender dowel pin with the rack dowel hole.
2. Apply low strength threadlocker on the provided M3 screws and secure the extender to the rack (0.50 Nm / 4.40 in-lb).
3. Align the fingertip dowel pins with extender dowel holes.
4. Apply low strength threadlocker on the provided M5 screw and secure the fingertip to the extender (5.65 Nm / 50.00 in-lb).
5. Repeat for the second fingertip if necessary.

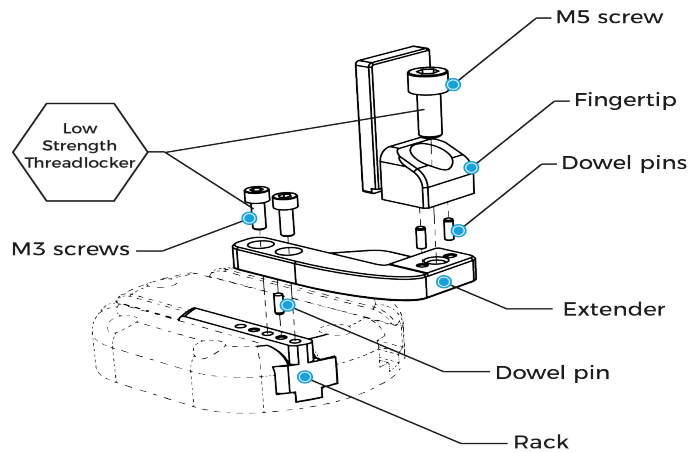

Fig. 3-4: Mounting extenders on fingers, and extenders on racks.

3.5. Electrical Setup

Power and communication are established with the Hand-E Gripper via a single device cable. The device cable provides a 24V power supply to the gripper and enables serial RS485 communication to the robot controller.

Info

RS485 signals (485+, 485- and 485 GND) are isolated from the main 24V power supply. GND can be connected to any other ground reference as long as the voltage potential between the grounds does not exceed 250V. Grounding reference is at the user's discretion.

3.5.1. Electrostatic Discharge Safety

Robotiq Hand-E Gripper is not ESD safe. If installed properly using the tooth lock washers, the casing and internal mechanism are grounded through the screws used to mount the gripper on the coupling. The same is true for the coupling. For the Hand-E Gripper, the top part mounted on the casing using 6 screws, the fingertips and rails are isolated from the rest of the gripper. It is therefore not possible to discharge any electrostatic charge that would build up on the part through the gripper.

3.5.2. Pinout Interface

The gripper interfaces with its coupling via a 10-spring pin connector located on its outer surface.

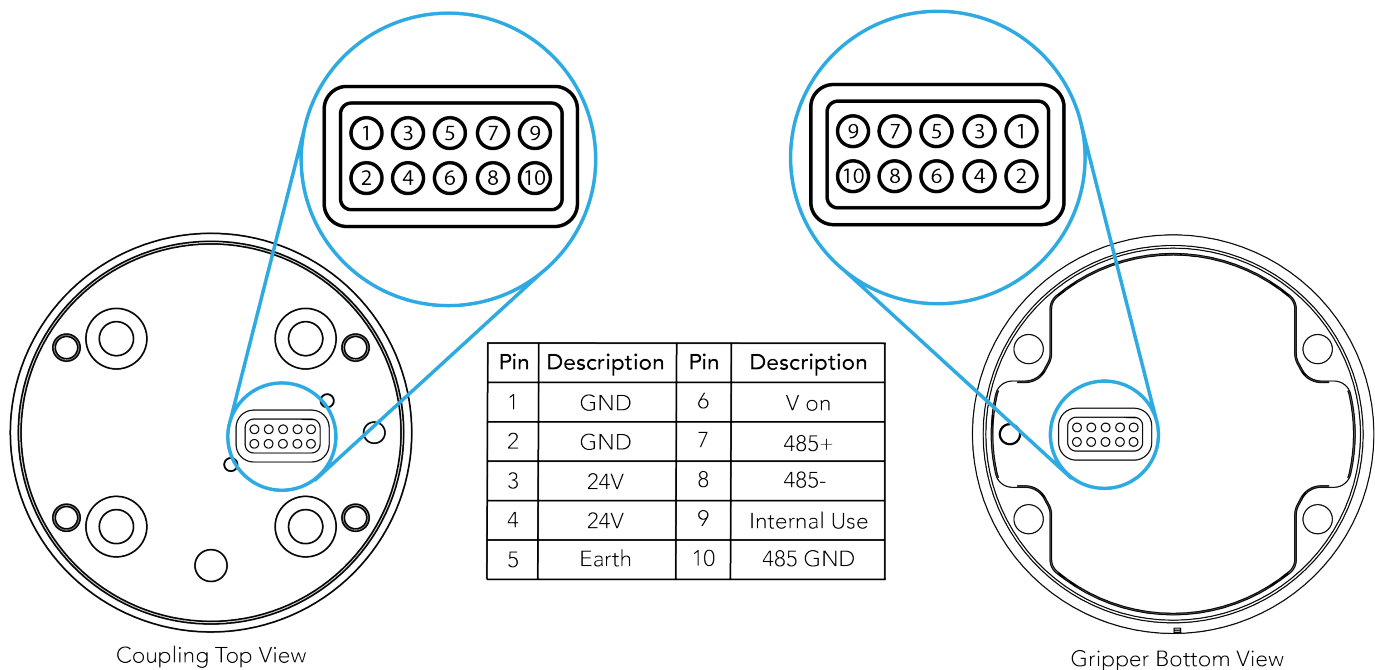

Fig. 3-5: Pinout to the Hand-E Gripper cable-to-wrist coupling.



3.5.3. Coupling to Controller

To connect a gripper to a network or robot controller via fieldbus communication, you can use the Robotiq Universal Controller . For details on the Robotiq Universal Controller, see its Instruction Manual on robotiq.com/support.

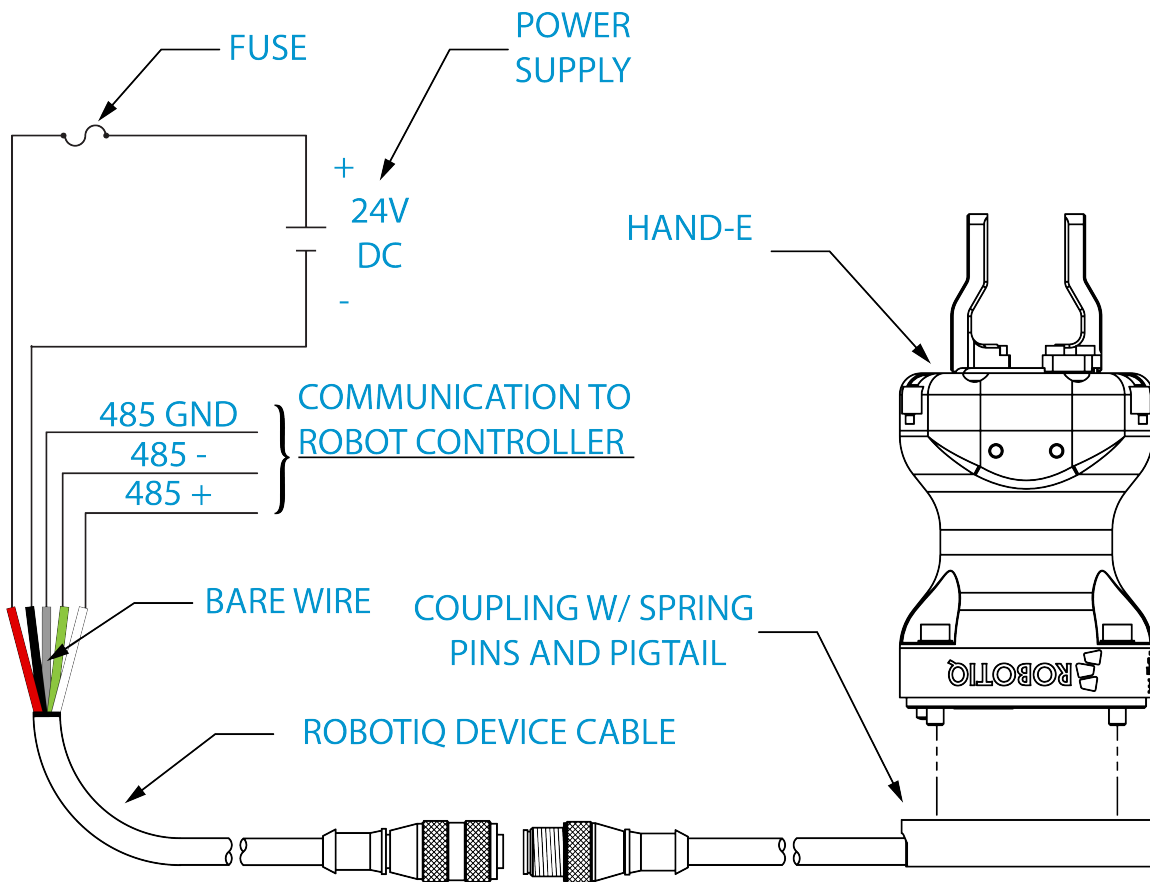

Fig. 3-6: Robotiq Hand-E with pigtail cable and device cable wiring scheme.

Tip

To control robots for which no driver package is available, we recommend the Robotiq Universal Controller, which supports the following fieldbus communication protocols:

- Modbus TCP
- EtherNet IP
- EtherCAT
- PROFINET
- DeviceNET
- CANopen



4. Control

Info

Unless specified, all values in this section are in hexadecimal values.

4.1. Overview

Tip

To test various gripper features such as object detection and force control, use the Robotiq User Interface. To download it, go to robotiq.com/support, click on **Select product > Hand-E Adaptive Gripper > [any robot brand] > Software > Robotiq User Interface > DOWNLOAD ZIP**.

Since the Robotiq Hand-E Gripper has its own embedded controller, you can use high-level commands such as "Go to requested position" to control it.

Info

The operator can control force, speed, and position of gripper fingers.

- Finger movement is always synchronized.
- Finger movement is initiated via a single "Go to requested position" command.
- Object detection is built-in. Operator is notified after an object is picked once the "Go to" command has been initiated.
- In case of emergency, auto-release is engaged (open or close).



Control using registers

Grippers share their internal memory with a robot controller. One part of the memory is for the robot output; **gripper functionalities**. The other part of the memory is for the robot input; **gripper status**. Two types of actions are then available to a robot controller:

1. Write in the **robot output** registers to activate **functionalities**;
2. Read in the **robot input** registers to get the **status** of the gripper.

The **Gripper Register Mapping** section maps the registers used to control the gripper or to read its status while the **Robot Output Registers & Functionalities** section details the output (write) register functions, and **Robot Input Registers and Status** section details the input (read) register status. The figure below is a representation of the memory and the control logic of the gripper. For details, see the **Control Logic Example** section

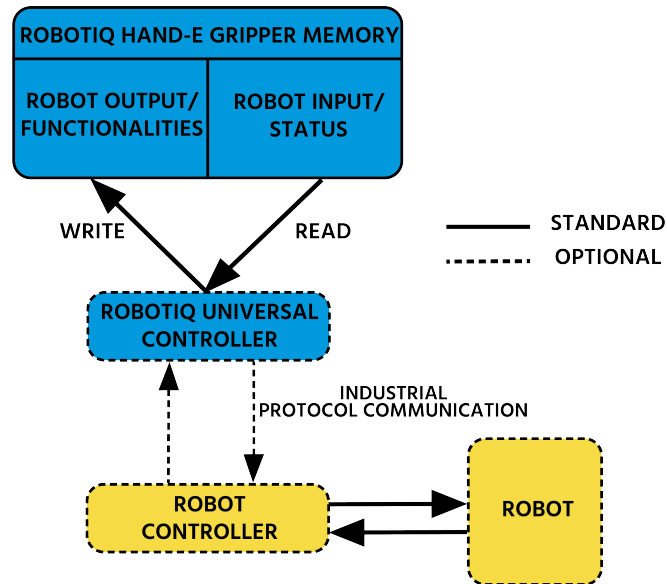

Fig. 4-1: Hand-E control logic overview

4.2. Gripper Register Mapping

Caution

Byte numbering starts at zero and not at 1 for the functionalities and status registers.

Register	Robot Output / Functionalities	Robot Input / Status
Byte 0	ACTION REQUEST	GRIPPER STATUS
Byte 1	RESERVED	RESERVED
Byte 2	RESERVED	FAULT STATUS
Byte 3	POSITION REQUEST	POS REQUEST ECHO
Byte 4	SPEED	POSITION
Byte 5	FORCE	CURRENT
Byte 6 to 15	RESERVED	RESERVED

Table 4-1: Registers of the Hand-E Gripper.



4.3. Robot Output Registers & Functionalities

4.3.1. Register: ACTION REQUEST

Address: **Byte 0**

Bits	7	6	5	4	3	2	1	0
Symbols	Reserved		rARD	rATR	rGTO	Reserved		rACT

rACT

First action to be made prior to any other actions; the **rACT** bit will activate the gripper. Clear the **rACT** bit to reset the gripper and clear any fault status.

- 0x0 - Deactivate Gripper.
- 0x1 - Activate Gripper (must stay on after activation routine is completed).

Warning

When setting **rACT** ($rACT == 1$), the gripper will begin movement to complete its activation feature.

Info

Power loss will set **rACT** ($rACT == 1$); the **rACT** bit must then be cleared ($rACT == 0$), then set again to allow operation of the gripper.

Caution

The **rACT** bit must stay on afterwards for any other action to be performed.

rGTO

The "Go To" action moves the gripper fingers to the requested position using the configuration defined by the other registers, **rGTO** will engage motion while bytes 3, 4 and 5 will determine aimed position, force and speed. The only motions performed without the **rGTO** bit are activation and automatic release routines.

- 0x0 - Stop.
- 0x1 - Go to requested position.

rATR

Automatic Release routine action slowly opens the gripper fingers until all motion axes reach their mechanical limits. After all motions are completed, the gripper sends a fault signal and needs to be reinitialized before any other motion is performed. The **rATR** bit overrides all other commands excluding the activation bit (**rACT**).

- 0x0 - Normal.
- 0x1 - Emergency auto-release.



Caution

The automatic release is meant to disengage the gripper after an emergency stop of the robot. The automatic release is not intended to be used under normal operating conditions. Automatic release requires the rACT to be cleared (rACT == 0) then set (rACT == 1).

rARD

Auto-release direction. When auto-releasing, **rARD** commands the direction of the movement. The **rARD** bit should be set prior to or at the same time as the **rATR** bit, as the motion direction is set when the auto-release is initiated.

- 0x0 - Closing auto-release
- 0x1 - Opening auto-release

4.3.2. Register: GRIPPER OPTIONS

Address: **Byte 1**

Bits	7	6	5	4	3	2	1	0
Symbol	Reserved							

4.3.3. Register: GRIPPER OPTIONS 2

Address: **Byte 2**

Bits	7	6	5	4	3	2	1	0
Symbol	Reserved							

4.3.4. Register: POSITION REQUEST

Address: **Byte 3**

Bits	7	6	5	4	3	2	1	0
Symbol	rPR							

This register is used to set the target position for the gripper's fingers. The positions 0x00 and 0xFF correspond respectively to the fully opened and fully closed mechanical stops. For detailed finger trajectory, see the **Specifications** section.

- 0x00 - Open position, with 50 mm opening
- 0xFF - Closed
- Opening / count: ≈ 0.2 mm for 50 mm stroke

Info

The activation will allow the gripper to adjust to any fingers/fingertips. No matter what is the size and/or shape of the fingers/fingertips, 0 will always be fully opened and 255 fully closed, with a quasi-linear relationship between the two values.



4.3.5. Register: SPEED

Address: **Byte 4**

Bits	7	6	5	4	3	2	1	0
Symbol	rSP							

This register is used to set the gripper closing or opening speed in real time, however, **setting a speed will not initiate a motion.**

- 0x00 - Minimum speed
- 0xFF - Maximum speed

4.3.6. Register: FORCE

Address: **Byte 5**

Bits	7	6	5	4	3	2	1	0
Symbol	rFR							

The force setting defines the final gripping force for the gripper. The force will fix the maximum current sent to the motor . If the current limit is exceeded, the fingers stop and trigger an object detection notification. Please refer to the **Picking Features** section for details on force control.

- 0x00 - Minimum force
- 0xFF - Maximum force

Info

Register bytes 6 to 15 are reserved and should be set to 0.

4.4. Robot Input Registers and Status

4.4.1. Register: GRIPPER STATUS

Address: **Byte 0**

Bits	7	6	5	4	3	2	1	0
Symbols	gOBJ	gSTA	gGTO	Reserved	Reserved		gACT	

gACT

Activation status, echo of the **rACT** bit (activation bit).

- 0x0 - Gripper reset.
- 0x1 - Gripper activation.



gGTO

Action status, echo of the **rGTO** bit (**go to bit**).

- 0x0 - Stopped (or performing activation / automatic release).
- 0x1 - Go to Position Request.

gSTA

Gripper status, returns the current status and motion of the gripper fingers.

- 0x00 - Gripper is in reset (or automatic release) state. See Fault Status if gripper is activated.
- 0x01 - Activation in progress.
- 0x02 - Not used.
- 0x03 - Activation is completed.

gOBJ

Object detection status, is a built-in feature that provides information on possible object pick-up. Ignore if **gGTO** == 0.

- 0x00 - Fingers are in motion towards requested position. No object detected.
- 0x01 - Fingers have stopped due to a contact while opening before requested position. Object detected opening.
- 0x02 - Fingers have stopped due to a contact while closing before requested position. Object detected closing.
- 0x03 - Fingers are at requested position. No object detected or object has been loss / dropped.

Caution

In some circumstances the object detection feature may not detect an object even if it is successfully grasped. For instance, picking up a thin object may be successful without the object detection status being triggered. In such applications, the "Fingers are at requested position" status of register gOBJ is sufficient to proceed to the next step of the routine.

Tip

Checking for the correct position of the fingers (byte 4), **as well as** object detection (byte 0, bit 6 & 7) before proceeding to the next step of a routine is a more reliable method than object detection or finger position alone.

4.4.2. Register: RESERVED

Address: **Byte 1**

Bits	7	6	5	4	3	2	1	0
Symbol	Reserved							



4.4.3. Register: FAULT STATUS

Address: **Byte 2**

Bits	7	6	5	4	3	2	1	0
Symbols	kFLT				gFLT			

gFLT

Fault status returns general error messages that are useful for troubleshooting. Fault LED (red) is present on the gripper chassis, LED can be blue, red or both and be solid or blinking.

- 0x00 - No fault (solid blue LED)
- Priority faults (solid blue LED)
 - 0x05 - Action delayed; the activation (re-activation) must be completed prior to perform the action.
 - 0x07 - The activation bit must be set prior to performing the action.

Minor faults (solid red LED)

- 0x08 - Maximum operating temperature exceeded (≥ 85 °C internally); let cool down (below 80 °C).
- 0x09 - No communication during at least 1 second.

Major faults (LED blinking red/blue) - Reset is required (rising edge on activation bit (**rACT**) needed).

- 0x0A - Under minimum operating voltage.
- 0x0B - Automatic release in progress.
- 0x0C - Internal fault, contact support@robotiq.com
- 0x0D - Activation fault, verify that no interference or other error occurred.
- 0x0E - Overcurrent triggered.
- 0x0F - Automatic release completed.

Info

While booting, status LED will be solid blue/red.

kFLT

See your optional controller manual (input registers and status).



4.4.4. Register: POSITION REQUEST ECHO

Address: **Byte 3**

Bits	7	6	5	4	3	2	1	0
Symbol	gPR							

gPR

Echo of the requested position for the gripper, value between 0x00 and 0xFF.

- 0x00 - Full opening.
- 0xFF - Full closing.

4.4.5. Register: POSITION

Address: **Byte 4**

Bits	7	6	5	4	3	2	1	0
Symbol	gPO							

gPO

Actual position of the gripper obtained via the encoders, value between 0x00 and 0xFF.

- 0x00 - Fully opened.
- 0xFF - Fully closed.

4.4.6. Register: CURRENT

Address: **Byte 5**

Bits	7	6	5	4	3	2	1	0
Symbol	gCU							

gCU

The current is read instantaneously from the motor drive, value between 0x00 and 0xFF, approximate current equivalent is 10 * value read in mA.

Tip

Built-in features like object detection and force control use the fingers' electrical current readings. The user does not need to create these features.



4.5. Picking Features

As stated in previous sections, object picking is done via a simple "Go To" command, **rGTO** bit calls for movement, while **rPR** byte is the aimed position, **rSP** and **rFR** will be the desired speed and force settings respectively. This section describes key features in object picking applications:

- Force control
- Re-grasp
- Object detection
- Object contact loss

4.5.1 Force control

The gripping force is controlled via the **rFR** byte (please refer to the **Robot Output Registers & Functionalities** section). The gripper behavior will change according to the **rFR** force requested.

- **rFR = 0** : Very fragile objects
 - Lowest force
 - Re-grasp feature is off
- **1 rFR 255** : Fragile to robust objects
 - Re-grasp feature is on

Object type	Solid Fragile	Deformable Fragile	Solid Robust
rFR value	0	1	255
Force Level	Low Force		High Force
Re-grasp	OFF	ON	

4.5.2 Re-Grasp

Re-grasp feature is a built-in feature meant to prevent object lost due to slipping or inaccurate initial grip. The Re-grasp feature allows the gripper to initiate movement when an object is slipping or dropped. When Re-grasping, the gripper will attempt to close until it reaches the position request (**rPR**).

- This feature is automatically set according to the force request **rFR**.

Info

Feature is off at force request **rFR = 0**, otherwise it is on.

- Re-grasp will keep the position setting:
 - Finger motion will stop when **rPR** position is reached, even if there is no object.



- Force and speed settings are not used, Re-grasp force and speed will automatically adjust to keep the object from being lost / dropped.

Info

While your initial settings for force and speed are not used for Re-grasp, they will never be exceeded to prevent damaging the part.

Caution

The rOBJ status is cleared when a motion is detected.

4.5.3. Object detection

When the gripper grabs an object, the **gOBJ** status will allow you to know if contact with the object was successful. This is a built-in feature for adaptive grippers meant to be used by the robot controller (or PLC) commanding the overall application. The Object detection feature will change the gOBJ status and can be used inside your robot program.

As stated in the previous section:

gOBJ: Only valid if **gGTO** = 1.

- 0x00 - Fingers are in motion towards requested position. No object detected.
- 0x01 - Fingers have stopped due to a contact while opening before requested position. Object detected.
- 0x02 - Fingers have stopped due to a contact while closing before requested position. Object detected.
- 0x03 - Fingers are at requested position. No object detected or object has been lost / dropped.

Example of contact detected with an object:

1. Set position, speed and force at maximum (full closing):
 - a. **rPR** == 0xFF, **rSP** == 0xFF, **rFR** == 0xFF,
2. Set "go to requested" will initiate movement :
 - a. **rGTO** == 0x01
3. Then object detection status will be "in motion"
 - a. **gOBJ** == 0x00
4. Until an object is picked, object detection status will then be "stopped due to contact while closing"
 - a. **gOBJ** == 0x02
5. The user can now assume it is holding the payload, and proceed to the next step.

Example of contact lost with an object:

1. From the previous example, after an object is picked
 - a. **gOBJ** == 0x02
2. If the gOBJ status displays 0x03 after it was 0x02, user can assume contact with the object has been lost.



4.5.4. Brake engagement

Hand-E is equipped with a brake that engages at the end of every gripper move, and disengages between moves. For instance, when fully closing on an object, the gripper touches the object, activates the brake, and sends the object detection signal to the robot.



4.6. Control Logic Example

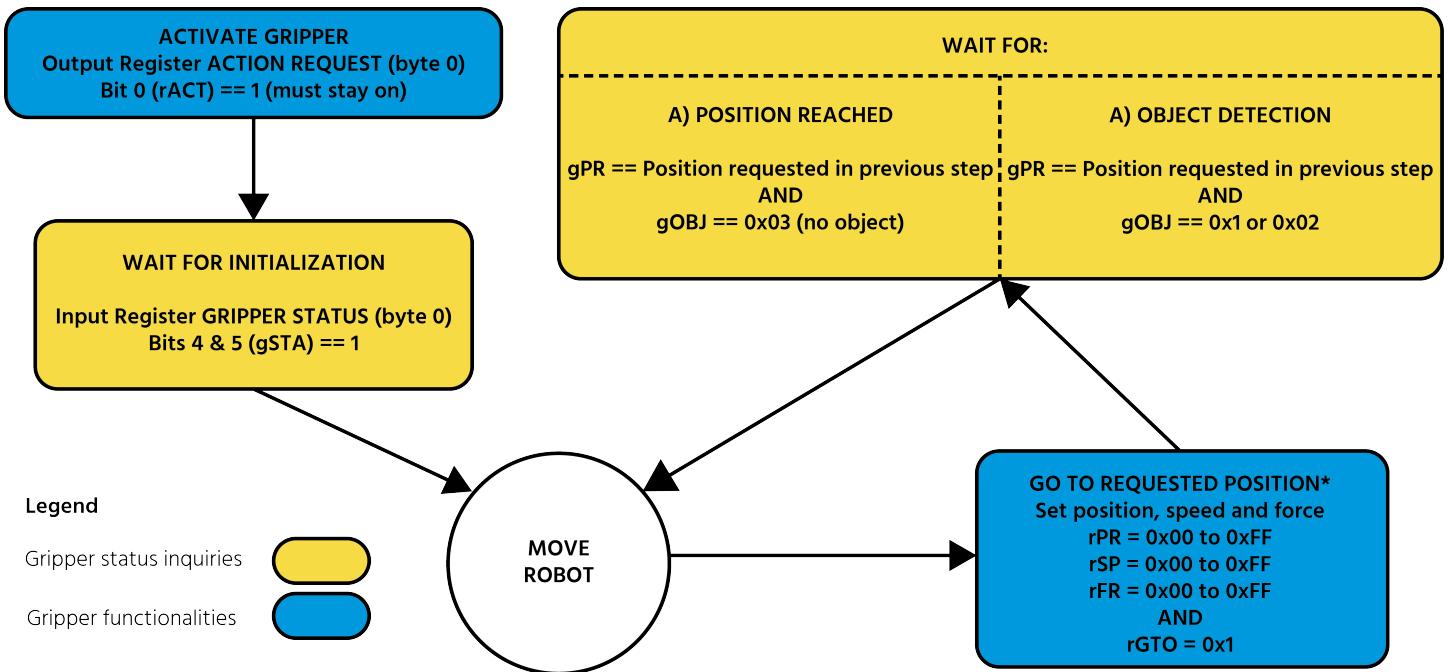

Go to requested position is used to open/close the Gripper until a contact with the object is detected, or the requested position is reached.

Fig. 4-2: Example of Gripper control logic with corresponding registers.

4.7. Modbus RTU Communication

The gripper can be controlled by Modbus RTU directly with RS485 or over USB using the ACC-ADT-USB-RS485. This section is intended to provide guidelines for setting up a Modbus master that will adequately communicate with the gripper.

For a general introduction to Modbus RTU and for details regarding the CRC algorithm, the reader is invited to read the Modbus over serial line specification and implementation guide available at: http://www.modbus.org/docs/Modbus_over_serial_line_V1_02.pdf.

For debugging purposes, the reader is also invited to download one of many free Modbus scanners such as the *CAS Modbus Scanner* from *Chipkin Automation Systems* available at: <http://www.store.chipkin.com/products/tools/cas-modbus-scanner>.

Info

Modbus RTU is a communication protocol based on a Big Endian byte order. Therefore, the 16-bit register addresses are transmitted with the most significant byte first. However, the data port is in the case of Robotiq products based on the Little Endian byte order. As such, the data parts of Modbus RTU messages are sent with the less significant byte first.

Tip

Modbus RTU specifications and details can be found at www.modbus.org.



4.7.1. Connection Setup

The following table describes the connection requirements for controlling the gripper using the Modbus RTU protocol.

PROPRIETY	DEFAULT VALUE
Physical Interface	RS-485 ¹
Baud Rate ²	115,200 bps
Data Bits	8
Stop Bit ²	1
Parity ²	None
Supported Functions	Read Input Registers (FC04) Preset Multiple Registers (FC16) Master read & write multiple registers (FC23)
Exception Responses	Not supported
Slave ID ²	0x0009 (9)
Robot Output / Gripper Input First Register	0x03E8 (1000)
Robot Input / Gripper Output First Register	0x07D0 (2000)
Termination Resistor ²	120 ohms

¹ Various converters are available in the **Spare Parts, Kits and Accessories** section.

² These parameters can be adjusted using the Robotiq User Interface.

Each register (word - 16 bits) of the Modbus RTU protocol is composed of **2** bytes (8 bits) from the gripper. The first gripper output Modbus register(0x07D0) is composed from the first **2** Robotiq Gripper bytes (byte 0 and byte 1).

Info

200 Hz is the maximum speed when commanding / reading from the Robotiq Gripper. It is therefore recommended to send commands with a minimum delay of 5 ms between them.

Info

Maximum baud rate of **ACC-ADT-USB-RS485** is 115200 bps.

120 Ohms termination resistor is already present on the converter and the Gripper. If multiple grippers are connected in parallel on the same RS485 cable, termination resistor must be set to OFF in communication parameters.



4.7.2. Read input registers (FC04)

Function code 04 (FC04) is used for requesting the status of the gripper analog input register. Examples of such data are gripper status, object status, finger position, etc.

Example of an FC04 read function:

This message asks for register 0x07D0 (2000) and register 0x07D1 (2001) which contains Gripper Status, Object Detection, Fault Status and Position Request Echo.

Request is: 09 04 07 D0 00 02 70 0E

Bits	Description
09	SlaveID
04	Function Code 04 (Read Input Registers)
07D0	Address of the first requested register
0002	Number of registers requested (2)
700E	Cyclic Redundancy Check (CRC)

Response is: 09 04 04 E0 00 00 00 45 84

Bits	Description
09	SlaveID
04	Function Code 04 (Read Input Registers)
04	Number of data bytes to follow (2 registers x 2 bytes/register = 4 bytes)
E000	Content of register 07D0
0000	Content of register 07D1
4584	Cyclic Redundancy Check (CRC)



4.7.3. Preset multiple registers (FC16)

Function code 16 (FC16) is used to activate functionalities of the gripper (robot output). Examples of such data are action request, speed, force, etc.

Example of setting multiple registers FC16:

This message requests to set position request, speed and force of the gripper by setting register 0x03E9 (1002) and 0x03EA.

Request is: 09 10 03 E9 00 02 04 60 E6 3C C8 EC 7C

Bits	Description
09	SlaveID
10	Function Code 16 (Preset Multiple Registers)
03E9	Address of the first register
0002	Number of registers written to
04	Number of data bytes to follow (2 registers x 2 bytes/register = 4 bytes)
60E6	Value written to register 0x03E9
3CC8	Value written to register 0x03EA
EC7C	Cyclic Redundancy Check (CRC)

Response is: 09 10 03 E9 00 02 91 30

Bits	Description
09	SlaveID
10	Function Code 16 (Preset Multiple Registers)
03E9	Address of the first register
0002	Number of written registers
9130	Cyclic Redundancy Check (CRC)



4.7.4. Master read and write multiple registers FC23

Function code 23 (FC23) is used for reading the status of the gripper (robot input) and activating gripper functionalities (robot output) simultaneously. Examples of such data are gripper status, object status, finger position, etc. Action requests are speed, force, etc.

Example of reading and writing multiple registers FC23:

This message reads registers 0x07D0 (2000) and 0x07D1 (2001), which contains Gripper Status, Object Detection, Fault Status and Position Request Echo. It also sets the position request, speed and force of the gripper by writing to registers 0x03E9 (1001) and 0x03EA (1002).

Request is: 09 17 07 D0 00 02 03 E9 00 02 04 00 E6 3C C8 2D 0C

Bits	Description
09	SlaveID
17	Function Code 23 (read and write multiple registers)
07D0	Address of the first requested register, read
0002	Number of registers requested (2), read
03E9	Address of the first register written to
0002	Number of registers written to (2)
04	Number of data bytes to follow (2 registers X 2 bytes/registers = 4 bytes)
00E6	Value written to register 0x03E9
3CC8	Value written to register 0x03EA
2D0C	Cyclic Redundancy Check (CRC)



Response is: 09 17 04 01 00 09 E6 F6 C1

Bits	Description
09	SlaveID
17	Function Code 23 (read and write multiple registers)
04	Number of data bytes to follow (2 registers x 2 bytes/register = 4 bytes)
1000	Content of register 07D0
09E6	Content of register 07D1
F6C1	Cyclic Redundancy Check (CRC)

Tip

Response contents might change depending on gripper status.

Info

Gripper executes the input command ("write" command), executes one cycle of motion, updates the output, then returns the Modbus response read.



4.7.5. Modbus RTU example

This section depicts the example from the **Control Logic Example** section, when programmed using the Modbus RTU protocol. The example is typical of a pick and place application. After activating the gripper, the robot is moved to a pick-up location to grip an object. It moves again to a second location to release the gripped object.

Step 1: Activation Request (clear and set rACT)

Request is (clear rAct): 09 10 03 E8 00 03 06 00 00 00 00 00 00 73 30

Bits	Description
09	SlaveID
10	Function Code 16 (Preset Multiple Registers)
03E8	Address of the first register
0003	Number of registers written to
06	Number of data bytes to follow (3 registers x 2 bytes/register = 6 bytes)
0000	Value to write to register 0x03E9 (ACTION REQUEST = 0x01 and GRIPPER OPTIONS = 0x00): rACT = 1 for "Activate Gripper"
0000	Value written to register 0x03EA
0000	Value written to register 0x03EB
7330	Cyclic Redundancy Check (CRC)

Response is: 09 10 03 E8 00 03 01 30

Bits	Description
09	SlaveID
10	Function Code 16 (Preset Multiple Registers)
03E8	Address of the first register
0003	Number of written registers
0130	Cyclic Redundancy Check (CRC)



Request is (set rAct): 09 10 03 E8 00 03 06 01 00 00 00 00 00 72 E1

Bits	Description
09	SlaveID
10	Function Code 16 (Preset Multiple Registers)
03E8	Address of the first register
0003	Number of registers written to
06	Number of data bytes to follow (3 registers x 2 bytes/register = 6 bytes)
0100	Value to write to register 0x03E9 (ACTION REQUEST = 0x01 and GRIPPER OPTIONS = 0x00): rACT = 1 for "Activate Gripper"
0000	Value written to register 0x03EA
0000	Value written to register 0x03EB
72E1	Cyclic Redundancy Check (CRC)

Response is: 09 10 03 E8 00 03 01 30

Bits	Description
09	SlaveID
10	Function Code 16 (Preset Multiple Registers)
03E8	Address of the first register
0003	Number of written registers
0130	Cyclic Redundancy Check (CRC)



Step 2: Read Gripper status until the activation is completed

Request is: 09 04 07 D0 00 01 30 0F

Bits	Description
09	SlaveID
04	Function Code 04 (Read Input Registers)
07D0	Address of the first requested register
0001	Number of registers requested (1)
300F	Cyclic Redundancy Check (CRC)

Response (if the activation IS NOT completed): 09 04 02 11 00 54 A1

Bits	Description
09	SlaveID
04	Function Code 04 (Read Input Registers)
02	Number of data bytes to follow (1 register x 2 bytes/register = 2 bytes)
1100	Content of register 07D0 (GRIPPER STATUS = 0x11, RESERVED = 0x00): gACT = 1 for "Gripper Activation", gSTA = 1 for "Activation in progress"
54A1	Cyclic Redundancy Check (CRC)

Response (if the activation IS completed): 09 04 02 31 00 4D 61

Bits	Description
09	SlaveID
04	Function Code 04 (Read Input Registers)
02	Number of data bytes to follow (1 register x 2 bytes/register = 2 bytes)
3100	Content of register 07D0 (GRIPPER STATUS = 0x31, RESERVED = 0x00): gACT = 1 for "Gripper Activation", gSTA = 3 for "Activation is completed"
4D61	Cyclic Redundancy Check (CRC)



Step 3: Move the robot to the pick-up location

Step 4: Close gripper at full speed and full force

Request is: 09 10 03 E8 00 03 06 09 00 00 FF FF FF 42 29

Bits	Description
09	SlaveID
10	Function Code 16 (Preset Multiple Registers)
03E8	Address of the first register
0003	Number of registers written to
06	Number of data bytes to follow (3 registers x 2 bytes/register = 6 bytes)
0900	Value written to register 0x03E8 (ACTION REQUEST = 0x09 and GRIPPER OPTIONS = 0x00): rACT = 1 for "Activate Gripper", rGTO = 1 for "Go to Requested Position"
00FF	Value written to register 0x03E9 (GRIPPER OPTIONS 2 = 0x00 and POSITION REQUEST = 0xFF): rPR = 255/255 for full closing of the Gripper
FFFF	Value written to register 0x03EA (SPEED = 0xFF and FORCE = 0xFF): full speed and full force
4229	Cyclic Redundancy Check (CRC)

Response is: 09 10 03 E8 00 03 01 30

Bits	Description
09	SlaveID
10	Function Code 16 (Preset Multiple Registers)
03E8	Address of the first register
0003	Number of written registers
0130	Cyclic Redundancy Check (CRC)



Step 5: Read Gripper status until the grip is completed

Request is: 09 04 07 D0 00 03 B1 CE

Bits	Description
09	SlaveID
04	Function Code 04 (Read Input Registers)
07D0	Address of the first requested register
0003	Number of registers requested (3)
B1CE	Cyclic Redundancy Check (CRC)

Example of response if the grip **is not completed**: 09 04 06 39 00 00 FF 0E 0A B6 6D

Bits	Description
09	SlaveID
04	Function Code 04 (Read Input Registers)
06	Number of data bytes to follow (3 registers x 2 bytes/register = 6 bytes)
3900	Content of register 07D0 (GRIPPER STATUS = 0x39, RESERVED = 0x00): gACT = 1 for "Gripper Activation", gGTO = 1 for "Go to Position Request" and gOBJ = 0 for "Fingers are in motion"
00FF	Content of register 07D1 (FAULT STATUS = 0x00, POSITION REQUEST ECHO = 0xFF): the position request echo tells that the command was well received and that the GRIPPER STATUS is valid.
0E0A	Content of register 07D2 (POSITION = 0x0E, FINGER CURRENT = 0x0A): the position is 14/255 and the motor current is 100mA (these values will change during motion)
B66D	Cyclic Redundancy Check (CRC)



Example of response if the grip **is completed**: 09 04 06 B9 00 00 FF BD 00 5C 9A

Bits	Description
09	SlaveID
04	Function Code 04 (Read Input Registers)
06	Number of data bytes to follow (3 registers x 2 bytes/register = 6 bytes)
B900	Content of register 07D0 (GRIPPER STATUS = 0xB9, RESERVED = 0x00): gACT = 1 for "Gripper Activation", gGTO = 1 for "Go to Position Request" and gOBJ = 2 for "Fingers have stopped due to a contact while closing"
00FF	Content of register 07D1 (FAULT STATUS = 0x00, POSITION REQUEST ECHO = 0xFF): the position request echo tells that the command was well received and that the GRIPPER STATUS is valid.
BD00	Content of register 07D2 (POSITION = 0xBD, FINGER CURRENT = 0x00): the position is 189/255 (can be used to validate the size of the seized object)
5C9A	Cyclic Redundancy Check (CRC)

Step 6: Move gripper to release location

Step 7: Open the Gripper at full speed and full force

Request is: 09 10 03 E8 00 03 06 09 00 00 00 FF FF 72 19

Bits	Description
09	SlaveID
10	Function Code 16 (Preset Multiple Registers)
03E8	Address of the first register
0003	Number of registers written to
06	Number of data bytes to follow (3 registers x 2 bytes/register = 6 bytes)
0900	Value written to register 0x03E8 (ACTION REQUEST = 0x09 and GRIPPER OPTIONS = 0x00): rACT = 1 for "Activate Gripper", rGTO = 1 for "Go to Requested Position"
0000	Value written to register 0x03E9 (GRIPPER OPTIONS 2 = 0x00 and POSITION REQUEST = 0x00): rPR = 0/255 for full opening of the Gripper (partial opening would also be possible)
FFFF	Value written to register 0x03EA (SPEED = 0xFF and FORCE = 0xFF): full speed and full force
7219	Cyclic Redundancy Check (CRC)



Response is: 09 10 03 E8 00 03 01 30

Bits	Description
09	SlaveID
10	Function Code 16 (Preset Multiple Registers)
03E8	Address of the first register
0003	Number of written registers
0130	Cyclic Redundancy Check (CRC)

Step 8: Read Gripper status until the opening is completed

Request is: 09 04 07 D0 00 03 B1 CE

Bits	Description
09	SlaveID
04	Function Code 04 (Read Input Registers)
07D0	Address of the first requested register
0003	Number of registers requested (3)
B1CE	Cyclic Redundancy Check (CRC)



Example of response if the opening **is not completed**: 09 04 06 39 00 00 00 BB 10 71 06

Bits	Description
09	SlaveID
04	Function Code 04 (Read Input Registers)
06	Number of data bytes to follow (3 registers x 2 bytes/register = 6 bytes)
3900	Content of register 07D0 (GRIPPER STATUS = 0x39, RESERVED = 0x00): gACT = 1 for "Gripper Activation", gGTO = 1 for "Go to Position Request" and gOBJ = 0 for "Fingers are in motion"
0000	Content of register 07D1 (FAULT STATUS = 0x00, POSITION REQUEST ECHO = 0x00): the position request echo tells that the command was well received and that the GRIPPER STATUS is valid.
BB10	Content of register 07D2 (POSITION = 0xBB, FINGER CURRENT = 0x10): the position is 187/255 and the motor current is 160mA (these values will change during motion)
7106	Cyclic Redundancy Check (CRC)

Example of response if the opening **is completed**: 09 04 06 F9 00 00 00 0D 00 17 AA

Bits	Description
09	SlaveID
04	Function Code 04 (Read Input Registers)
06	Number of data bytes to follow (3 registers x 2 bytes/register = 6 bytes)
F900	Content of register 07D0 (GRIPPER STATUS = 0xF9, RESERVED = 0x00): gACT = 1 for "Gripper Activation", gGTO = 1 for "Go to Position Request" and gOBJ = 3 for "Fingers are at requested position"
0000	Content of register 07D1 (FAULT STATUS = 0x00, POSITION REQUEST ECHO = 0x00): the position request echo tells that the command was well received and that the GRIPPER STATUS is valid.
0D00	Content of register 07D2 (POSITION = 0x0D, FINGER CURRENT = 0x00): the position is 13/255 (the fingers have reached their software limit)
17AA	Cyclic Redundancy Check (CRC)

Step 9: To grip additional objects, loop from step 3.



5. Specifications

Info

This manual uses the metric system. Unless otherwise specified, **all dimensions are in millimeters.**

The following subsections provide data on the various specifications for Robotiq Hand-E Gripper.

- **Technical dimensions** section
 - Dimensions of the Gripper
 - Dimensions for custom (blank) coupling
 - Dimensions of couplings
 - Dimensions for custom fingertips
 - Dimensions of standard fingertips
- **Mechanical Specifications** section
- **Electrical specifications** section



5.1. Technical dimensions

5.1.1. Hand-E Gripper

The figure below represents the gripper dimensions with axes X, Y, Z, and origin referenced for finger motion.

Info

All technical drawings in the current section depict aluminum fingers.

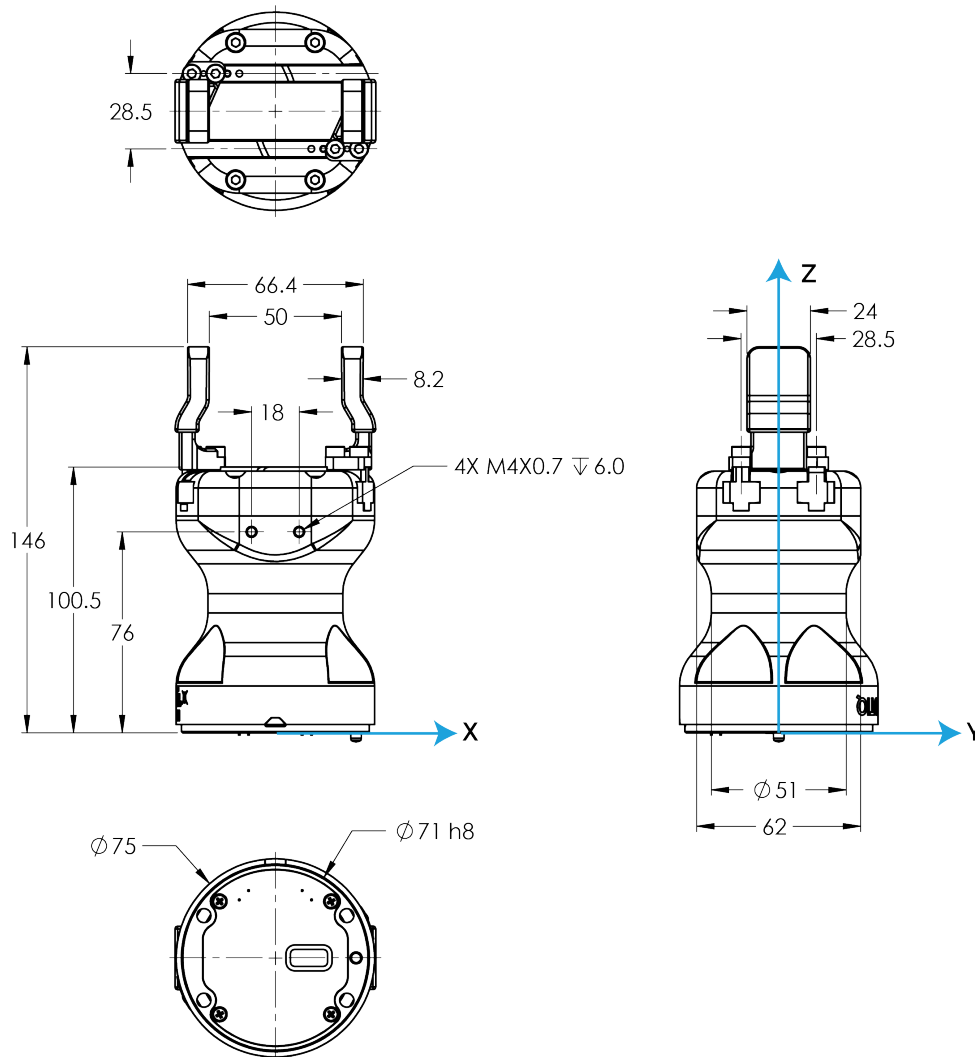

Fig. 5-1: General dimensions of Hand-E (open).



5.1.2. Couplings

The Hand-E Gripper requires a coupling provided by Robotiq to operate. The coupling is mandatory since it integrates electronics and electrical contacts.

Blank coupling

Below are the dimensions of the blank coupling, **AGC-CPL-BLANK-002** (please refer to the **Spare Parts, Kits and Accessories** section), available to create a custom bolt pattern. The blue section can be fully customized (holes can be placed in any part of this section) while the grey section can only be worked to a depth of 3 mm.

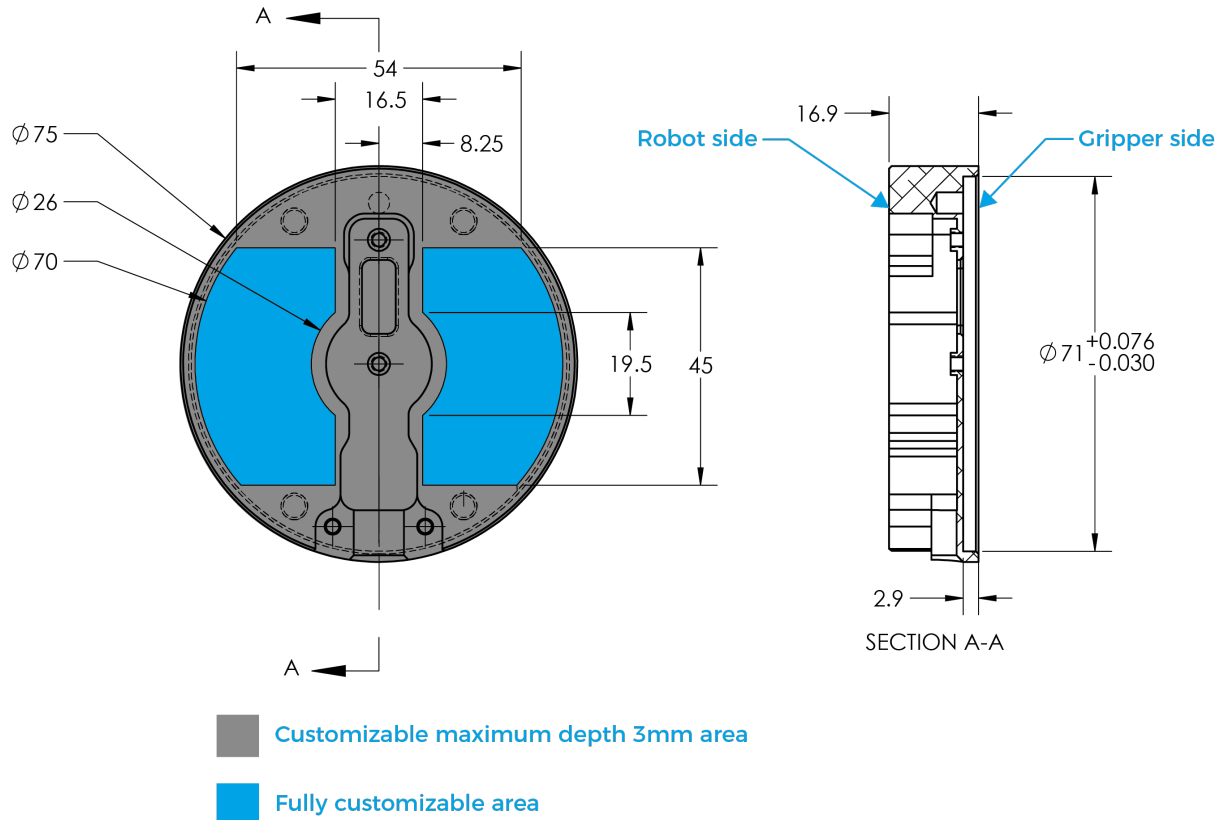

Fig. 5-2: Workable area dimensions of blank coupling AGC-CPL-BLANK-002



Coupling for ISO 9409-1-50-4-M6

Bolt pattern for coupling **GRP-CPL-062** and **GRP-ES-CPL-062** (please refer to the **Spare Parts, Kits and Accessories** section) is compatible with:

- 50 mm pitch circle diameter:
 - (4) M6-1.0 low head socket cap screw clearance
 - (1) M6 dowel pin
- ISO 9409-1 standard 50-4-M6

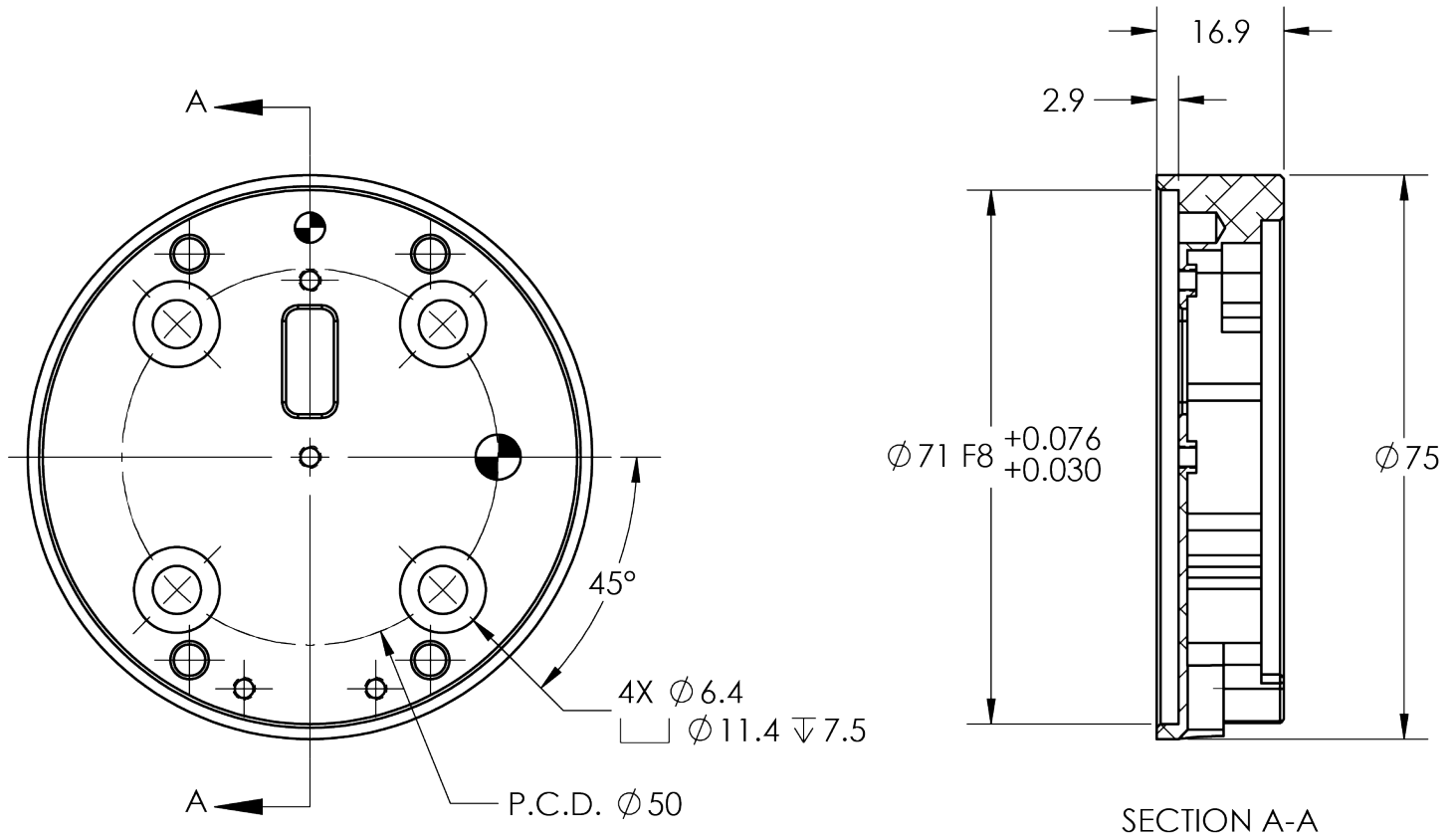

Fig. 5-3: Coupling for ISO 9409-1-50-4-M6.

Coupling for ISO 9409-1-31.5-4-M5

Bolt pattern for coupling **GRP-CPL-063** (please refer to the **Spare Parts, Kits and Accessories** section) is compatible with:

- 31.5 mm pitch circle diameter:
 - (4) M5-0.8 low head socket cap screw clearance
 - (1) M5 dowel pin
 - ISO 9409-1 standard 31.5-4-M5

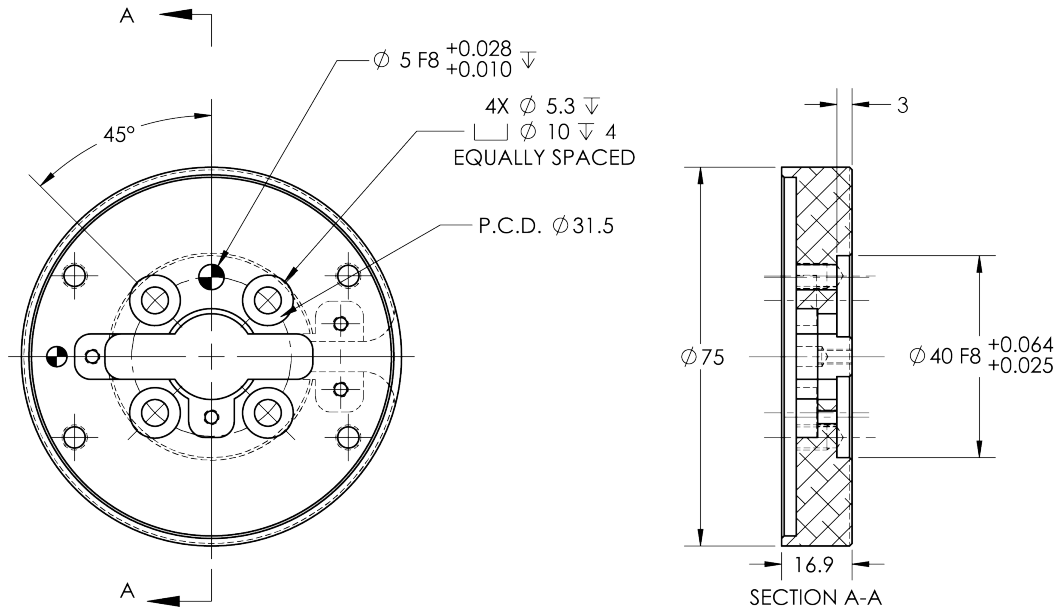

Fig. 5-4: Coupling for ISO 9409-1-31.5-4-M5.



Coupling for ISO 9409-1-40-4-M6

Bolt pattern for coupling **GRP-CPL-064** (please refer to the **Spare Parts, Kits and Accessories** section) is compatible with:

- 40 mm pitch circle diameter:
 - (4) M6-1.0 low head socket cap screw clearance
 - (1) M6 dowel pin
- ISO 9409-1 standard 40-4-M6

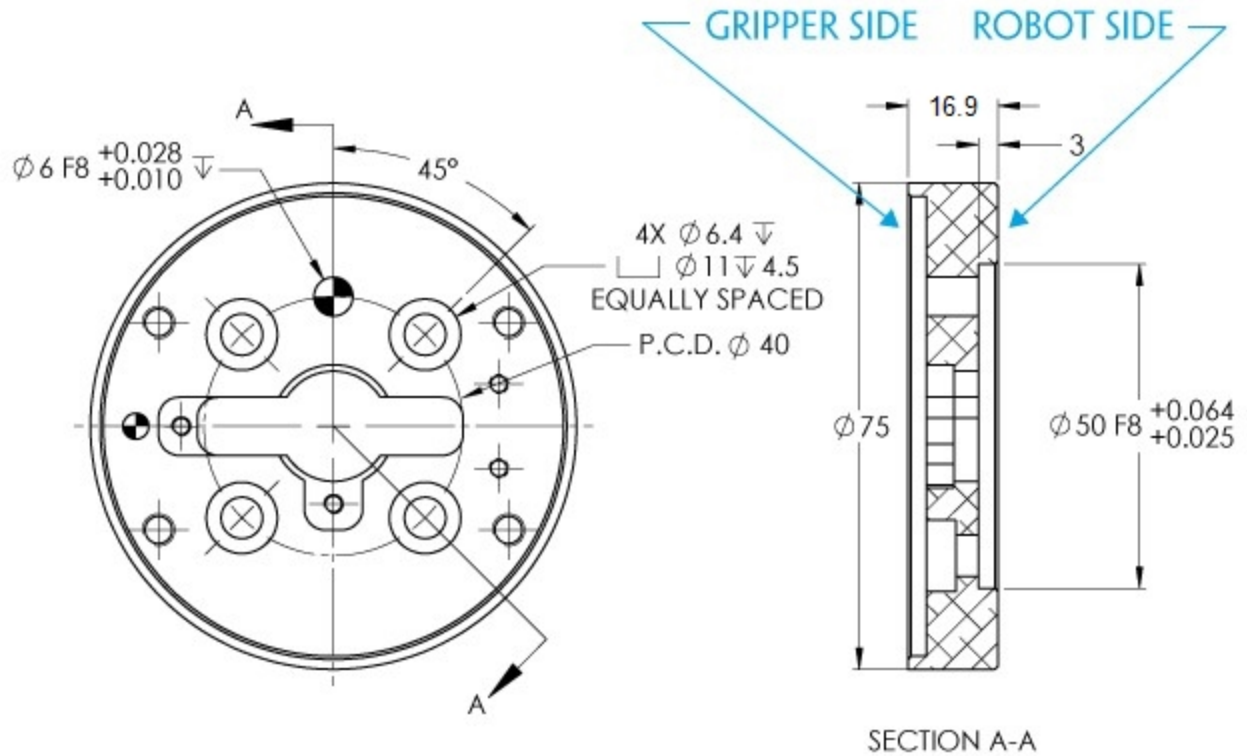

Fig. 5-5: Coupling for ISO 9409-1-40-4-M6.

Coupling for PCD 56 with 8 x M4

Bolt pattern for coupling AGC-CPL-065-002 (please refer to the **Spare Parts, Kits and Accessories** section) is compatible with:

- 56 mm pitch circle diameter:
 - (8) M4-0.7 low head socket cap screw clearance
 - (1) M4 dowel pin
- 62 mm diameter internal insert

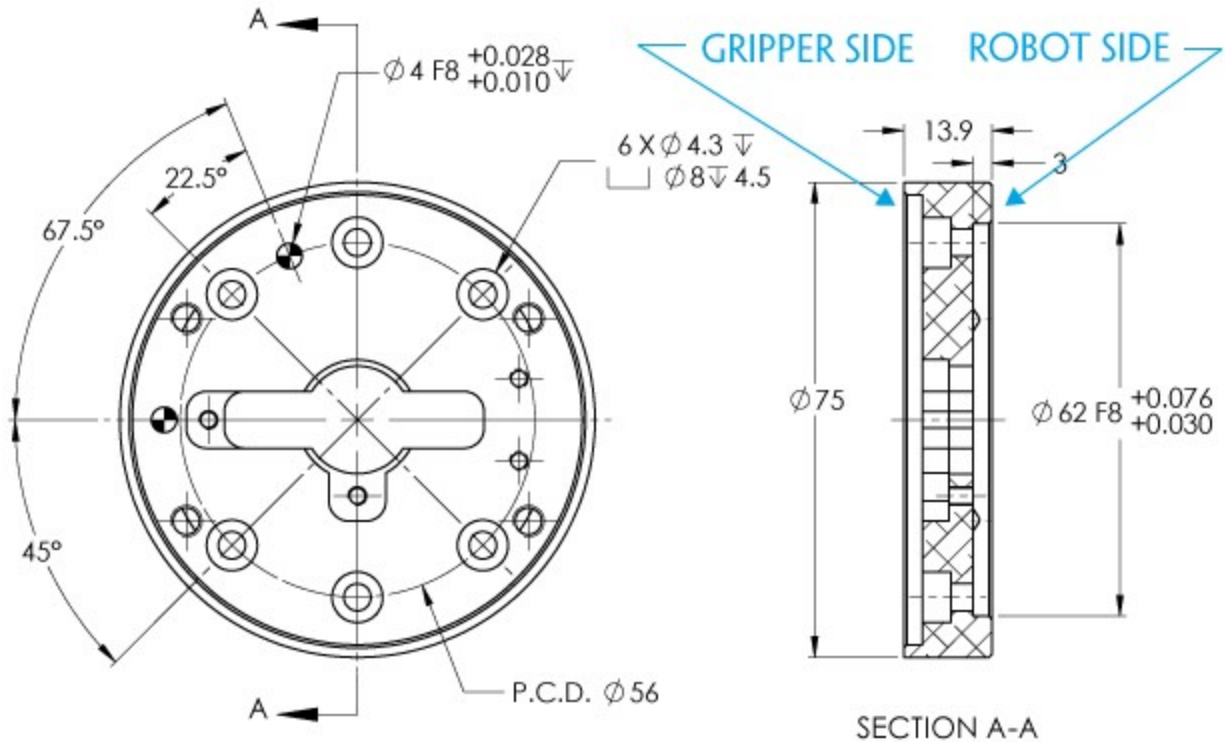

Fig. 5-6: Coupling for PCD 56 mm with 8 x M4 clearance.

Info

Although coupling AGC-CPL-065-002 is compatible with 8 x M4 threads on a 56 mm PCD it uses only 6 of the 8 normally present holes.



Coupling for PCD 56 with 6 x M4

Bolt pattern for coupling **AGC-CPL-066-002** (please refer to the **Spare Parts, Kits and Accessories** section) is compatible with:

- 56 mm pitch circle diameter:
 - (6) M4-0.7 low head socket cap screw clearance
 - (1) M6 dowel pin
 - 42 mm diameter external insert

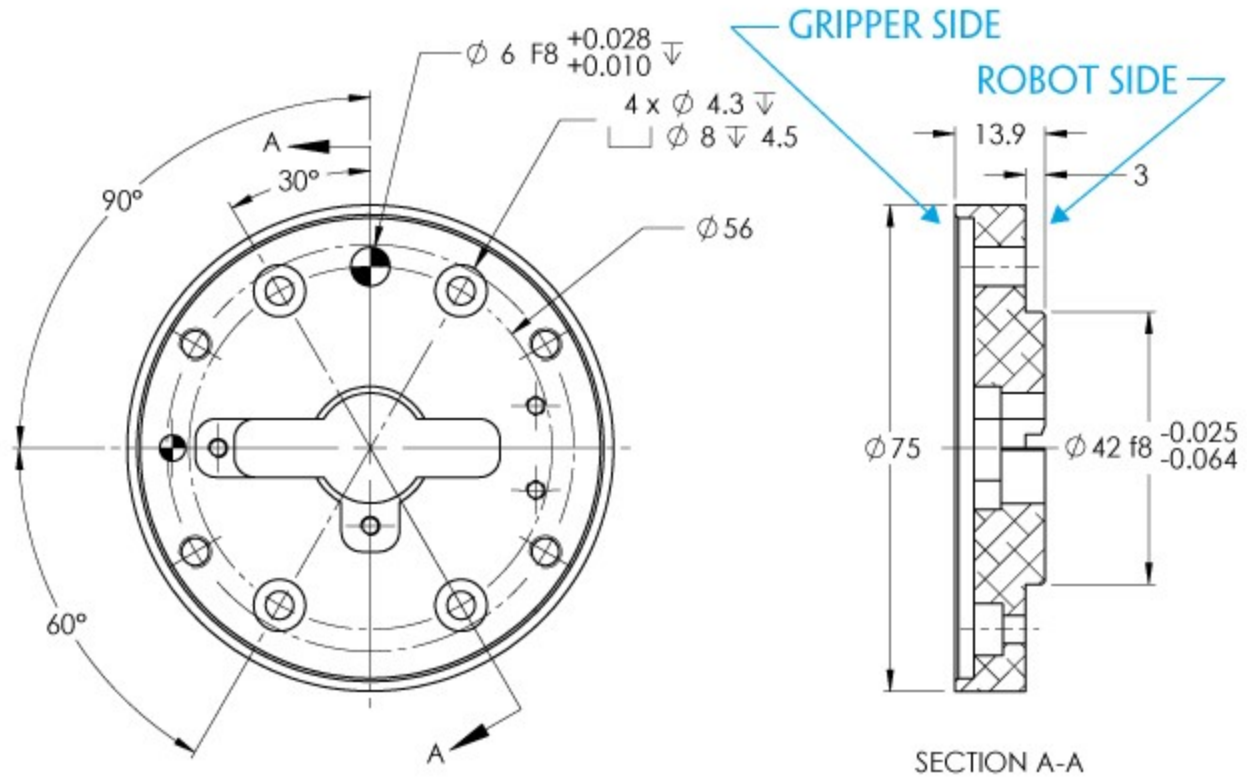

Fig. 5-7: Coupling for PCD 56 mm with 6 x M4 clearance.

Coupling for PCD 60 with 4 x M5

Bolt pattern for coupling **AGC-CPL-067-002** (please refer to the **Spare Parts, Kits and Accessories** section) is compatible with:

- 60 mm pitch circle diameter:
 - (4) M5-0.8 low head socket cap screw clearance
 - (1) M5 dowel pin
 - 34 mm diameter external insert

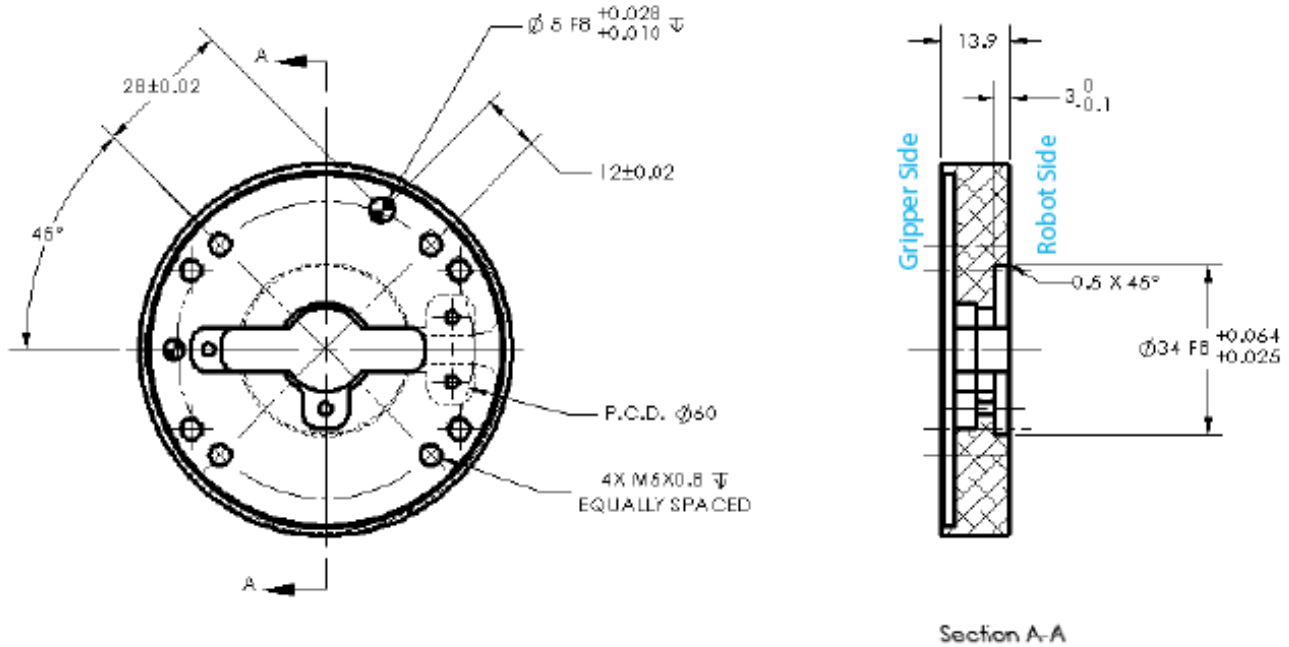

Fig. 5-8: Coupling for PCD 60 mm with 4 x M5 clearance.



Coupling for PCD 63 with 6 x M6

Bolt pattern for coupling AGC-CPL-068-002 (please refer to the **Spare Parts, Kits and Accessories** section) is compatible with:

- 63 mm pitch circle diameter:
 - (6) M6-1.0 low head socket cap screw clearance
 - (2) M6 dowel pins

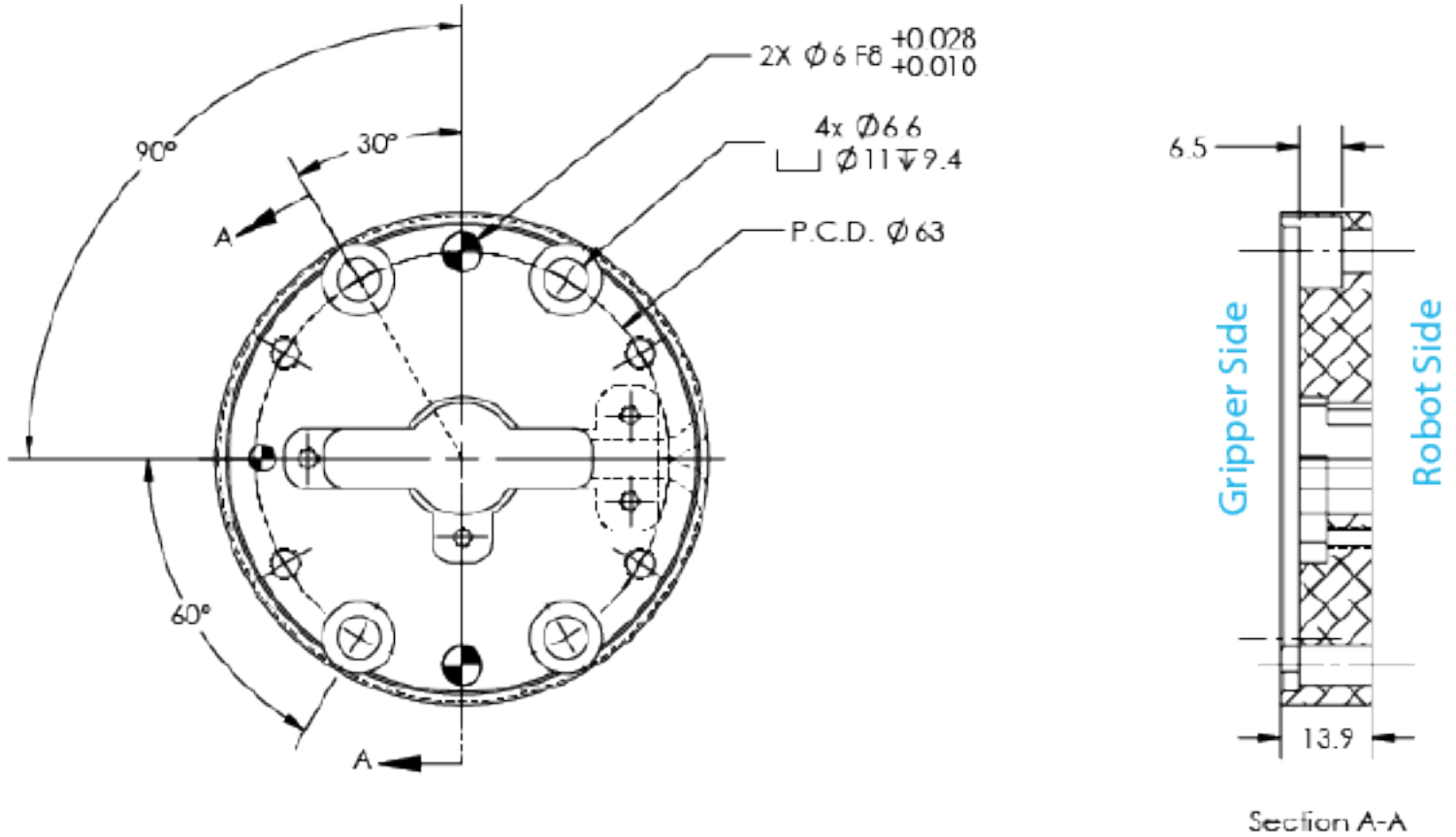

Fig. 5-9: Coupling for PCD 63 mm with 6 x M6 clearance.

5.1.3. Fingers and Fingertips

The contact grip points for Hand-E are its two fingertip pads.

Robotiq offers a selection of fingertips (see the **Spare Parts, Kits and Accessories** section), and users can create custom fingertips. The figure below represents the fingertip holder, the permanent, non customizable part of the gripper finger on which the fingertip must be mounted. Hand-E is shipped mounted with standard flat rubber (NBR) overmolded fingers.

Custom fingertip design must meet the following specifications:

- Forces exerted at the end of the fingertips must not exceed 100 N , regardless of the direction. Please refer to the **Moment and Force Limits** section for more details.

Warning

The following limits must be respected at all times.
Calculation of maximum moment and force should include robot acceleration and safety factors.

- Refer to the **Mechanical Specifications** section to evaluate the grip force according to your fingertip design.

Info

You can install custom fingertips directly on the rack or on the fingertip holder.

Tip

Fingertips can be mounted directly on racks or fingertip holders.

Rack

Fingers are installed directly on a rack. You may customize your own fingers to mount them on this part. NBR overmolded flat fingers (HND-FIN-MLD-KIT) are mounted directly onto it.

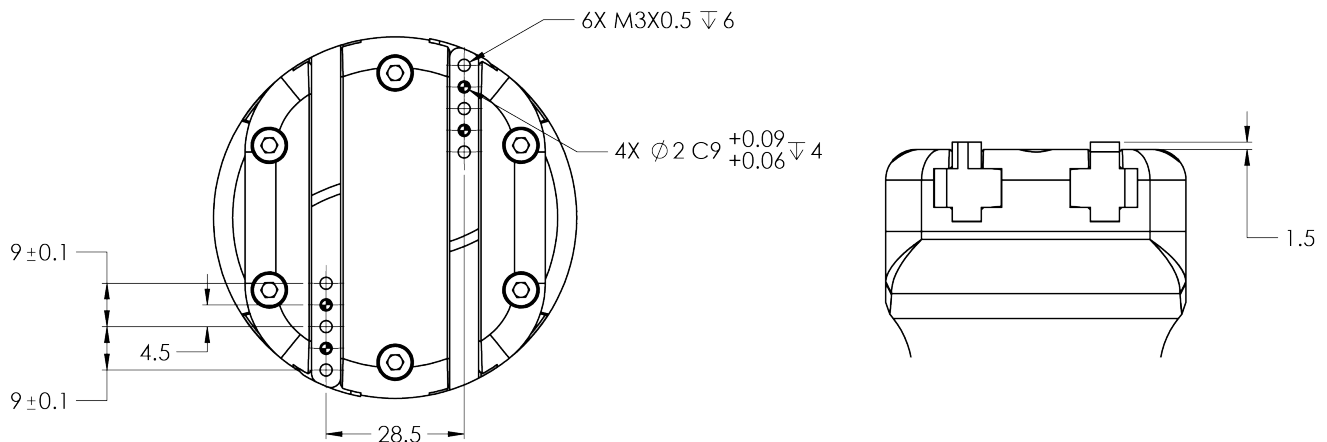

Fig. 5-10: Racks in rack housing



Fingertip Holders

To install fingertips on racks use fingertip holders (HND-TIP-HLD-KIT), and refer to the **Spare Parts, Kits and Accessories** section. You may customize fingertips to install directly on those. V-groove fingertips (HND-TIP-VGR-KIT) can be installed on fingertip holders.

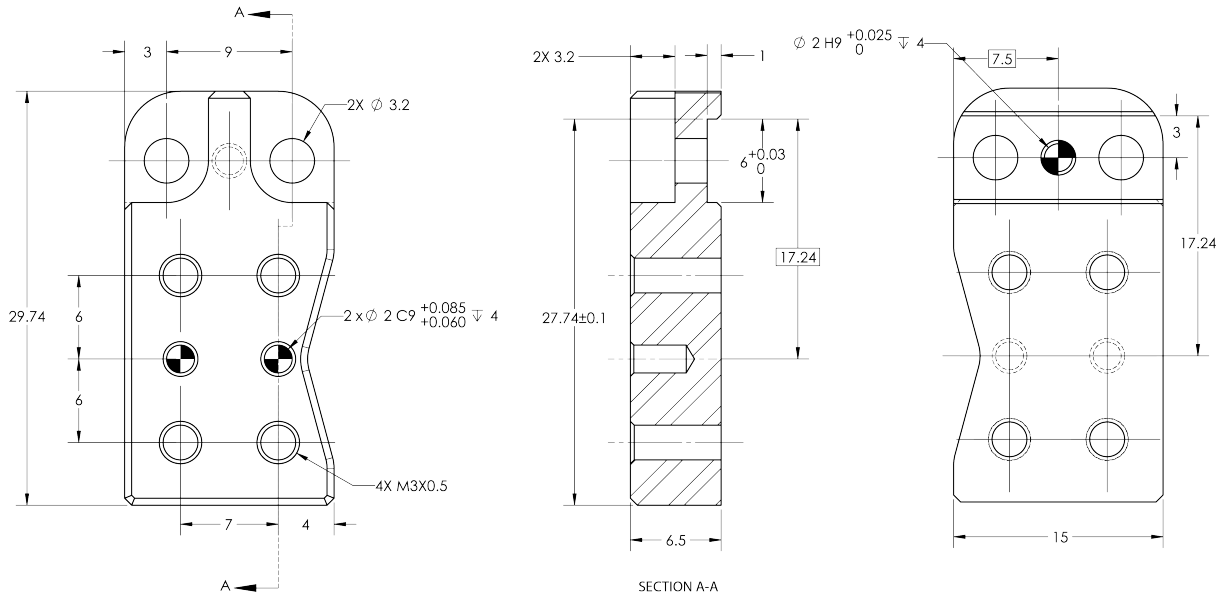

Fig. 5-11: Fingertip holder.

Fingertip Extenders

The figure below represents the fingertip extenders (HND-TIP-EXT-KIT). For details, see the **Spare Parts, Kits and Accessories** section. This extender allows an opening ranging from 40 up to 98 mm.

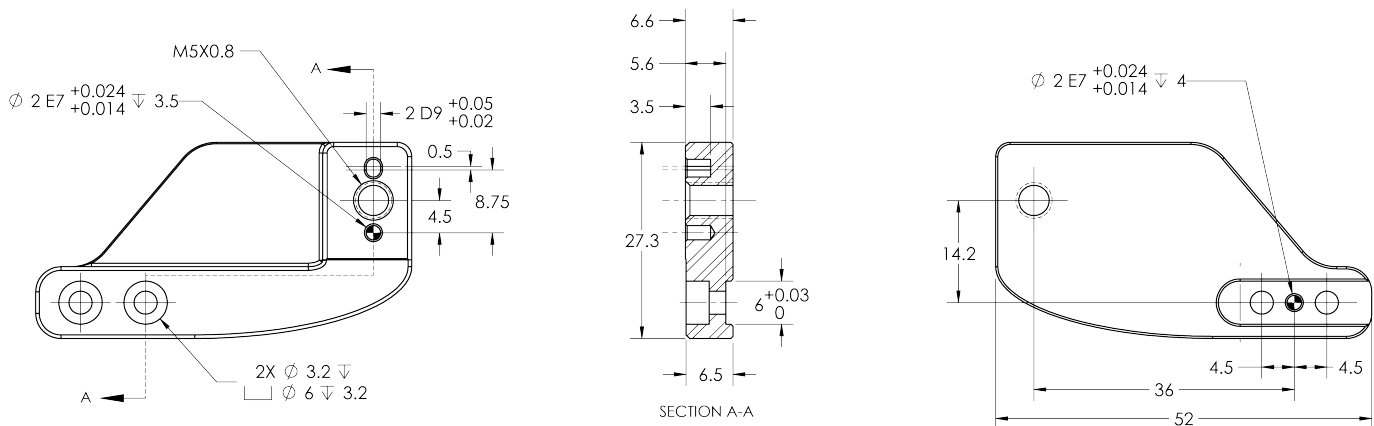

Fig. 5-12: Fingertip Extender

Flat Rubber (NBR) Overmolded Fingers

The figure below represents flat rubber (NBR) overmolded fingers (HND-FIN-MLD-KIT). For details, see the **Spare Parts, Kits and Accessories** section. This finger allows a 50 mm stroke.

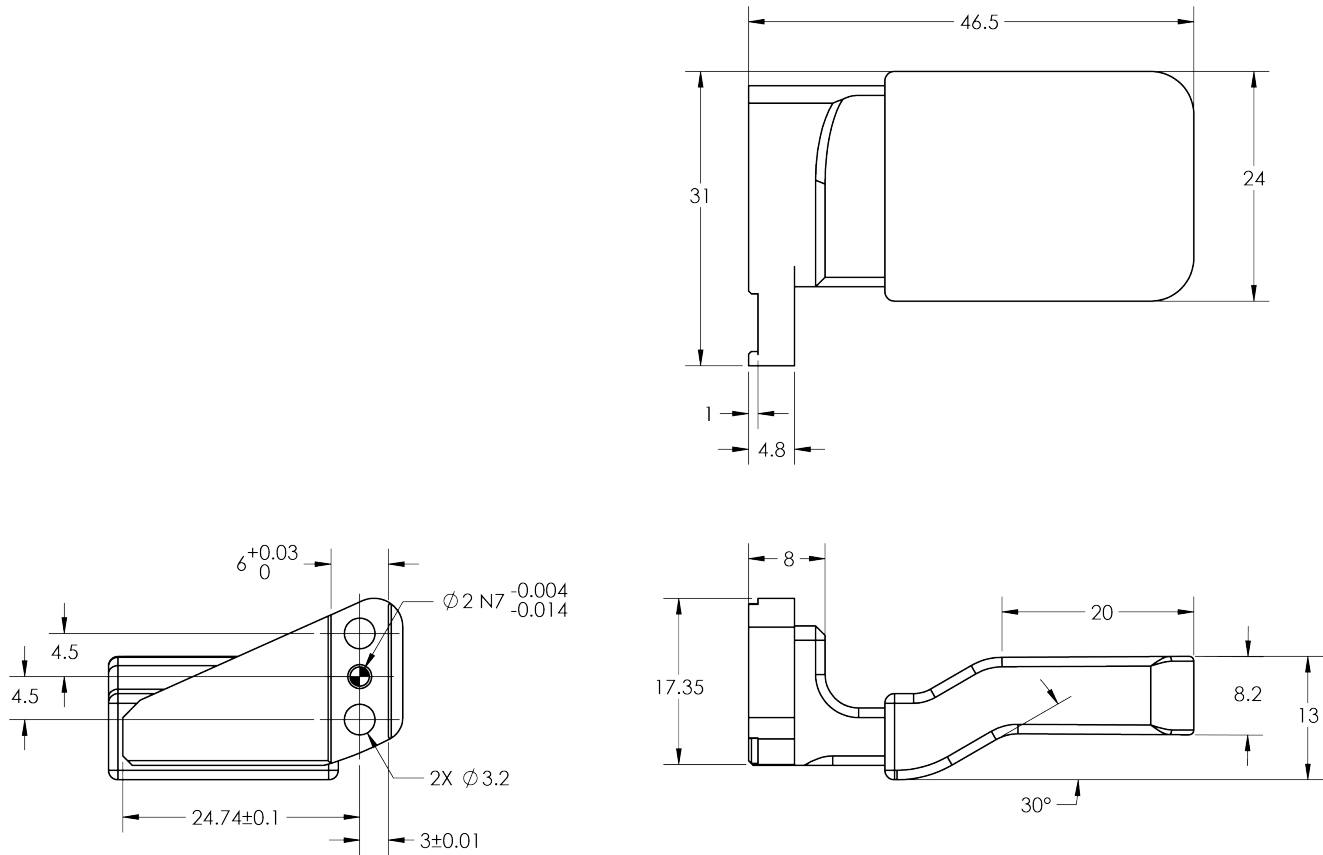

Fig. 5-13: Flat NBR overmolded finger.

Flat Aluminum Finger

The figure below represents a flat aluminum finger (HND-FIN-ALU-KIT). For more details, refer to the **Spare Parts, Kits and Accessories** section. This finger allows a 50 mm stroke.

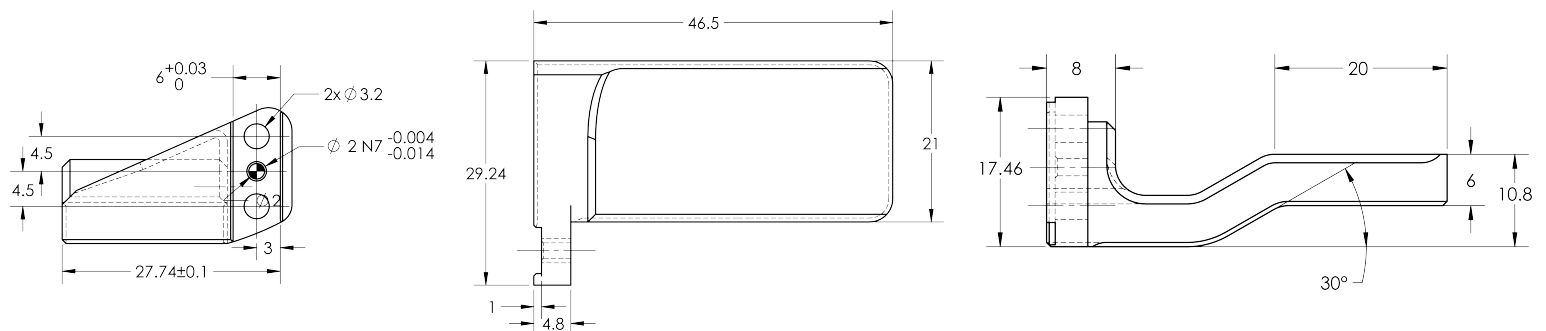

Fig. 5-14: Flat aluminum finger.

V-Groove Fingertip

The figure below shows the V-groove fingertip (HND-TIP-VGR-KIT). For details, see **Spare Parts, Kits and Accessories** section. This fingertip inner surface has vertical grooves, making it ideal for picking cylindrical parts. This fingertip must be mounted on the racks using the fingertip holder (HND-TIP-HLD-KIT).

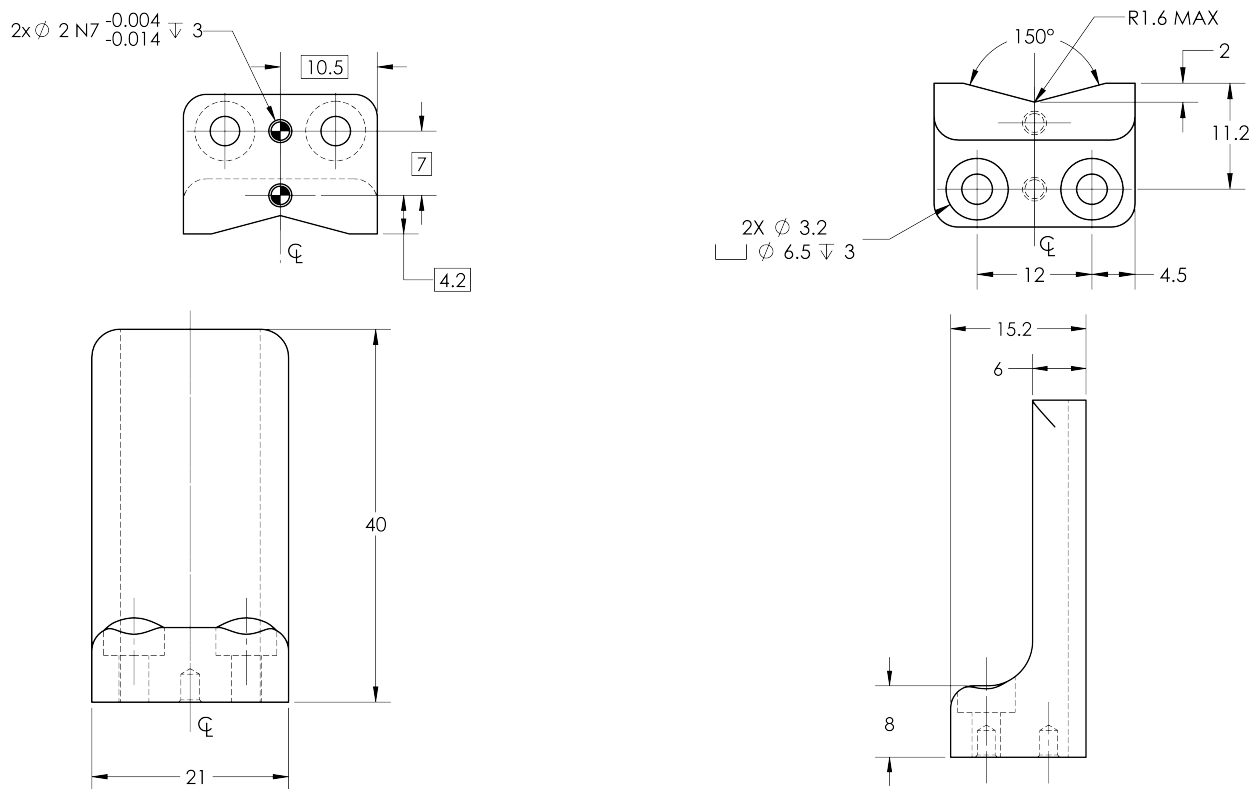

Fig. 5-15: Grooved fingertip

5.2. Mechanical Specifications

5.2.1. Hand-E Assembly

Info

Data shown in the table below is typical for new products, and will vary with use.

Specification	Metric	Imperial
Stroke	50 mm	1.97 in
Maximum recommended payload - Form-fit grasp	5 kg	11 lbs
Maximum recommended payload - Friction grasp	4.7 kg	10.3 lbs
Height - No fingertip	112 mm	4.41 in
Height - With fingertips	157 mm	6.18 in
Diameter	75 mm	2.95 in
Weight (with coupling)	1070 g	2.3 lbs
Grip force	20 N - 185 N	4.5 lbf - 41 lbf
Finger speed range	20 - 150 mm/sec	0.8 - 5.9 in/sec
Position repeatability ¹	0.025 mm	0.001 in
Position resolution ²	0.2 mm	0.008 in
Minimum part detection	0.5 mm	0.02 in

¹Repeatability is defined as the positional deviation resulting from the average displacement determined when picking an object using standard aluminium fingertips. For more details see the blog.robotiq.com article on repeatability. Position repeatability varies depending on the product wear and operating conditions. The presented values are typical for the newlymanufactured products.

²Resolution is the increment modified from a 1 bit difference of position/speed/force request (from 0 to 255).

Table 5-1: Mechanical specifications of the Hand-E Gripper fitted with coupling GRP-CPL-062 and aluminum fingertips (without NBR).



5.2.2. Payload and Force

Friction Grip payload equation:

Where:

- W is payload weight
- F is the force applied by the gripper to the load
- C_f is the friction coefficient between fingertip and part load
- S_f is a safety factor to be determined by the robot integrator

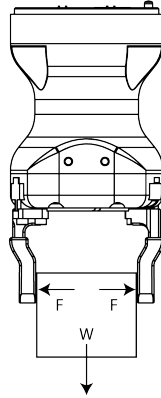

Fig. 5-16: Grasping force on Hand-E fingertips.

Info

The gripper has a power off brake. Without power, gripper fingers are blocked.

Info

For example, if the NBR overmolded fingertips (HND-FIN-MLD-KIT) are used to lift a lubricated steel part (machine tending with cutting oils), the friction coefficient would be 0.3 (tested static coefficient of friction).

The maximum weight with a safety factor of 2.4 using the maximum grasping force of 185 N would be:

$$W = (2 \times 185 \text{ N} \times 0.3) / 2.4 = 46.25 \text{ N}$$

This calculation means that a 4.7 kg part will be held by the gripper when not moving (standing still). When accelerating, the payload will decrease.

The biggest factor in such calculations will always be the **friction coefficient**, we recommend testing the coefficient.

Warning

In payload calculations, take **robot acceleration** into account.
Robot emergency stops will lead to major deceleration velocities.

Maximum payload/External force vs. Custom finger design

The maximum payload force recommended depends on the distance on the Z-axis at which the force/payload (F) is applied when using custom fingers on Hand-E.



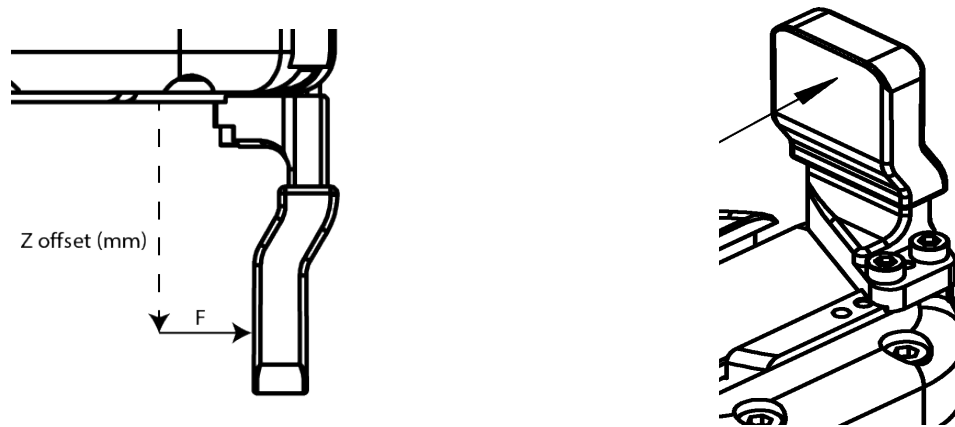

Fig. 5-17: Z-axis offset at which force/payload is applied.

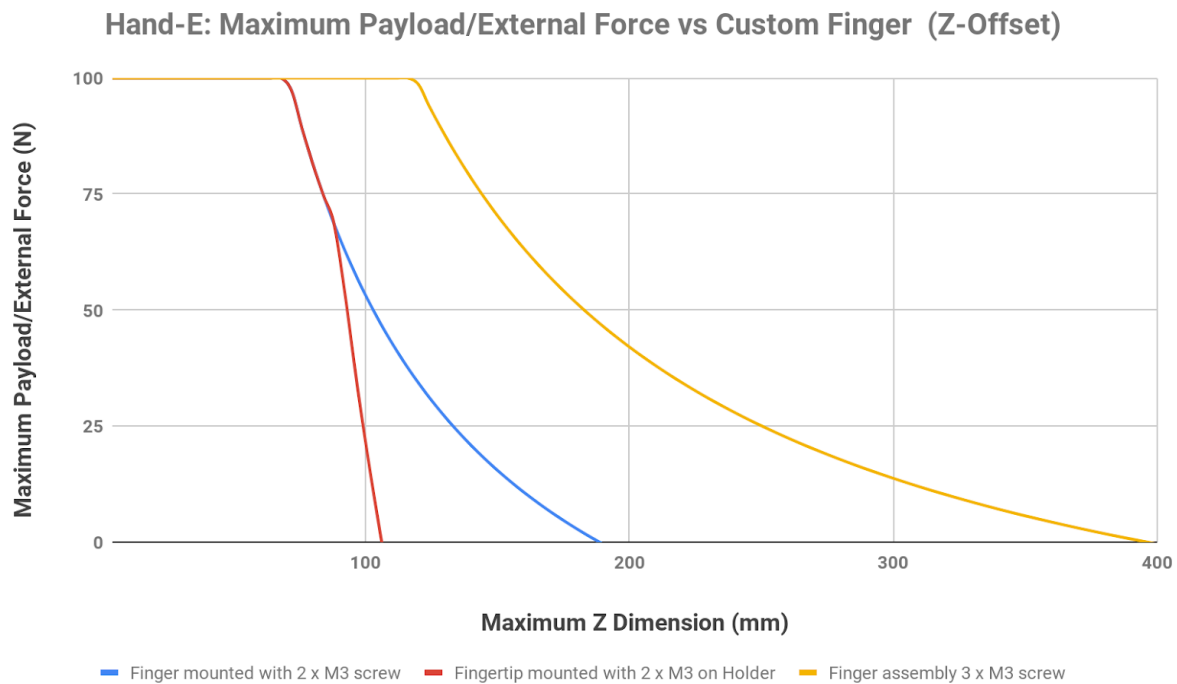

Fig. 5-18: Graph illustrating Maximum Payload/External Force vs. Z-Offset on Custom finger.

- The **blue curve** in the graph represents the maximum force/payload (F) recommended at given Z offset for a custom finger design **mounted directly on the rack with two (2) M3 screws**.
- The **red curve** in the graph represents the maximum force/payload (F) recommended at given Z offset for a custom finger design **mounted on a fingertip holder with two (2) M3 screws**.
- The **yellow curve** in the graph represents the maximum force/payload (F) recommended at given Z offset for a custom finger design **mounted directly on the rack with three (3) M3 screws**.

Info



Data is calculated at the resulting position of the force applied, based on the strength of the M3 screws used. Maximum grasping force is included in calculations. It represents the maximum force that can be added to the finger (payload force + external force).

Warning

Calculations do not take fatigue, robot acceleration and safety concerns into account.

Caution

In order to address other custom specific cases with regards to your own application, pay special attention to screws strength when mounting fingers.

Friction grasp and form-fit grasp

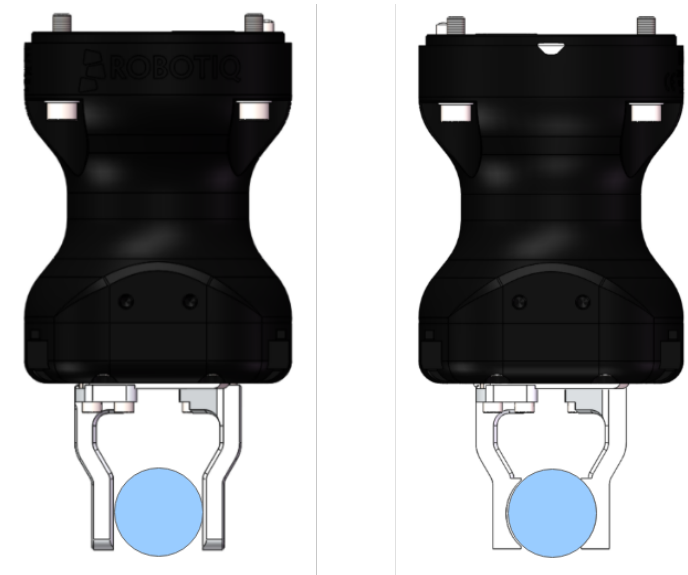

Fig. 5-19: Friction grasp and form-fit grasp.

Maximum payload by grasp type

Grasp Type	Maximum Payload
Friction grasp	4.7 kg
Form-fit grasp	5 kg



5.2.3. Center of Mass, Tool Center Point and Moment of Inertia

This table presents the center of mass and TCP of the Hand-E Gripper.

Product	Center of mass (mm)			TCP (mm)			Mass (g)
	X	Y	Z	X	Y	Z	
Hand-E Gripper	0.0	0.0	59.0	0.0	0.0	157.0	1068

Info

For TCP and center of mass of the Hand-E Gripper used in combination with other Robotiq products, please consult the specific table provided on our [support website](#).

Info

The angle to calculate the TCP for grippers mounted on a dual gripper assembly is as follows:

- Rx1 = 0
- Ry1 = 0.7854
- Rz1 = 0
- Rx2 = 1.22
- Ry2 = 0
- Rz2 = -2.887

The moment of inertia are calculated for a configuration where the fingers are fully open. Here is the approximate moment of inertia matrix for the gripper:

$$I = \begin{bmatrix} I_{XX} & I_{XY} & I_{XZ} \\ I_{YX} & I_{YY} & I_{YZ} \\ I_{ZX} & I_{ZY} & I_{ZZ} \end{bmatrix} = \begin{bmatrix} 5341 & 0 & 0 \\ 0 & 5447 & 0 \\ 0 & 0 & 636 \end{bmatrix} = \begin{bmatrix} 18.3 & 0 & 0 \\ 0 & 18.6 & 0 \\ 0 & 0 & 2.2 \end{bmatrix}$$

$\text{kg} \times \text{mm}^2$
 $\text{lb} \times \text{in}^2$

Fig. 5-20: Inertia matrix for Hand-E.



5.2.4. Moment and Force Limits

The Hand-E Gripper has limits for moment and force values. The maximum moment and force values are independent of the grasp force the gripper applies on its payload. For payload calculation, see the **Payload and Force** section.

Warning

Always operate within range.

Calculation of maximum moment and force should include robot acceleration and safety factors.

Parameter	Hand-E with Aluminum Fingers (without NBR)
F_x, F_y, F_z	100 N
M_x^*	2.65 Nm
M_y^*	3.74 Nm
M_z^*	2.00 Nm

*Moments in x and y are calculated from the base of the fingers, as shown in **Reference frame for maximum force and moment values applied to the fingers** section

Table 5-2: Maximum moment and force values

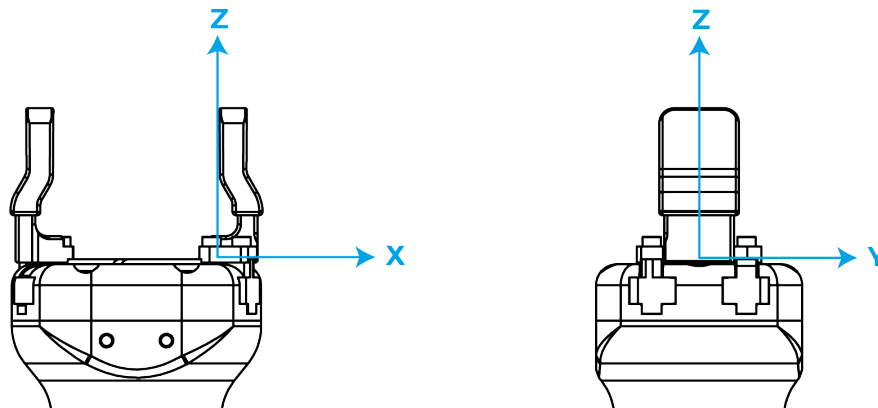

Fig. 5-21: Reference frame for maximum force and moment values applied to the fingers

Usage examples with listed limits:

- After picking its normal payload, the robot can use Hand-E to apply up to 100 N of force in any direction. Applying more than 100 N can damage the gripper or result in payload loss.
- A gripper can pick up a screwdriver and apply 2 Nm of torque to screw (such a moment would be applied in the Z axis).



5.3. Electrical specifications

SPECIFICATION	VALUE
Operating supply voltage	24 V DC \pm 10%
Quiescent power (minimum power consumption)	1 W
Peak current	680 mA



6. Maintenance

The Hand-E Gripper requires only external maintenance with limited downtime.

Maintenance is required after specified usage, measured in cycles (see Info box below for details about cycle definition).

Following the maintenance interval will ensure :

- Correct functioning of your gripper.
- Validity of your warranty.
- Proper lifetime for your gripper.

Warning

Unless otherwise indicated, any **repairs** done on the gripper will be performed by Robotiq.

Info

A cycle is defined as a **go to requested position** command that results in grip force being applied (closing the fingers on themselves or picking an object while opening or closing).

Operation	Daily	Weekly	1 M cycles	2 M cycles
Gripper Cleaning	Dirty conditions	Normal conditions		
Periodic Inspection			X	
Rack and pinion mechanism cleaning				X

Table 6-1: Maintenance Intervals.

Caution

Always turn off the robot and the gripper power supply before performing any maintenance operations.

Maintenance operations are for the average normal usage of the gripper, the maintenance intervals must be adjusted according to environmental conditions such as:

- Operating temperature
- Humidity
- Presence of chemicals
- Presence of physical parts (debris, scraps, dust, grease etc.)



- Interaction with operated parts (sharp or rough)
- Dynamics of the operation (accelerations)



6.1 Gripper cleaning

Maintenance Interval	Tools You Need	Parts You Need
Weekly or daily in dirty operating conditions	<ul style="list-style-type: none"> • 4 mm hex key • Dry tissue or towel • Low strength thread locker 	None (unless damage is detected)

Caution

Always turn off the robot and the gripper power supply before performing any maintenance operations.

Caution

The maintenance operator must be grounded to prevent electrostatic discharge that could damage the gripper electronics.

1. Remove the gripper from its coupling using the 4 mm hex key to unscrew the four (4) M5-0.8 x 25mm socket head cap screws. Note that each screw uses a tooth lock washer, do not lose them.
2. Clean the gripper with a dry towel, remove all debris, dirt and dust from the surface of the gripper, clean all pads, dry thoroughly.
3. Clean the coupling with a dry towel, pay particular attention to the electrical contact.
4. Visually inspect the gripper and pay attention to any visible damage.
5. Put the gripper back on and secure it with the four (4) M5-0.8 x 25mm socket head cap screws and tooth lock washers.

When cleaning the gripper, verify that the fingers or fingertips are still intact. If there is wear visible, you can change the fingers or fingertips, using the ones provided by Robotiq or custom ones. See **Spare Parts, Kits and Accessories** section to order Hand-E replacement parts.

In order to replace a finger:

1. Remove the worn finger by removing the M3 screws.
2. Clean the rack and dry thoroughly.
3. Insert the new finger on the rack.
4. Secure the finger using the provided M3 screws, apply low strength thread locker to the M3 screw threads.
5. Repeat for remaining finger.



In order to replace a fingertip:

1. Remove the worn fingertip by removing the M3 screws.
2. Clean the fingertip holder and dry thoroughly.
3. Insert the new fingertip in the fingertip holder.
4. Secure the fingertip using the provided M3 screws, apply low strength thread locker to the M3 screw threads.
5. Repeat for remaining fingertip.

6.2. Periodic inspection

Maintenance Interval	Tools You Need	Parts You Need
Monthly	<ul style="list-style-type: none"> • 4 mm hex key • Dry tissue or towel 	None (unless damage is detected)

Caution

Always turn off the robot and the gripper power supply before performing any maintenance operations.

1. Remove and clean the gripper following instructions in the **Gripper cleaning** section
2. Inspect the gripper
 - Finger or fingertip wear must not affect gripping, if wear is visible and affects movement, change accordingly (refer to the **Gripper cleaning** section)
 - Check for any collision damage, if damage is visible, contact support@robotiq.com
 - Check for any sign of wear on the gripper chassis; if wear is present and may affect the gripper, contact support@robotiq.com
3. Put back in place respecting to the instructions from the **Gripper cleaning** section
4. Finger movement must be symmetric and fluid; test opening and closing of the gripper:



6.3. Rack & pinion mechanism cleaning

Maintenance Interval	Tools You Need	Parts You Need
Every 2M cycles or more frequently in dirty operating conditions	<ul style="list-style-type: none"> • 4 mm hex key • Dry tissue or towel • Low strength thread locker • Grease (Mobilith SHC1500 or equivalent.) 	None (unless damage is detected)

Caution

Always turn off the robot and the gripper power supply before performing any maintenance operations.

1. Open the gripper to an intermediate position, so you do not hide the six (6) M4 screws holding the rack housing in place.
2. Remove the gripper from its coupling using the 4 mm hex key to unscrew the four (4) M5-0.8 x 25mm screws. Note that each screw uses a tooth lock washer, do not lose them.
3. Remove the six (6) M4 screws holding the rack housing.
4. Gently pull the rack housing away from the body of the gripper.
5. The finger's racks will slide off freely from the rack housing. Clean the rack housing, the racks and the pinion using a degreaser. Dry thoroughly. Clean the fingers (finger holders and fingertips if that is the case) with a dry towel. Remove all debris, dirt and dust
6. Clean the coupling with a dry towel, pay particular attention to the electrical contact.
7. Clean the gripper according to the procedure described in the **Gripper cleaning** section.
8. Visually inspect the gripper and pay attention to any visible damage.
9. Apply grease on the racks. Put it on **all surfaces except the face with the tapped holes**.

Info

Use Mobilith SHC1500 grease or an equivalent.

10. Slide the racks back in the rack housing.
11. Reinsert the rack housing with racks on the gripper. Make sure the racks go in symmetrically compared to the center of the gripper. As a reference, both distances **d** represented in the figure below should be the same.



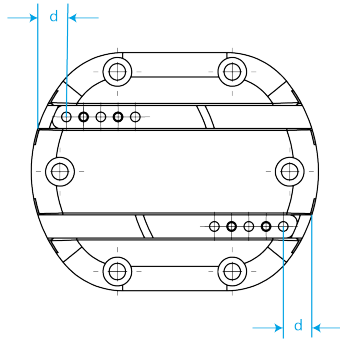

Fig. 6-1: Distance d : distance between racks and gripper frame.

12. Secure the rack housing using the six (6) M4 screws. Apply low strength thread locker to the M4 screw threads.
13. Put the gripper back on the coupling and secure it with the four (4) M5-0.8 x 25mm screws and tooth lock washers.

7. Spare Parts, Kits and Accessories

The following list is up-to-date at print time and is subject to change. Check online for updates.

Info

Unless specified, screws, dowel pins and other hardware are only included for grippers, and not for robots.

Item	Description	Ordering Number
Hand-E Basic Gripper Unit	Hand-E basic gripper unit, includes flat rubber (NBR) overmolded fingers (HND-FIN-MLD-KIT)	HND-GRP
Controller	Optional controller for industrial communications. See Robotiq Universal Controller manual for more information.	UNI-CTR-XXXX
Hand-E flat rubber (NBR) overmolded finger kit	<ul style="list-style-type: none"> • 2 x flat rubber (NBR) overmolded fingertips • 1 x screw kit 	HND-FIN-MLD-KIT
Aluminum Finger Kit	<ul style="list-style-type: none"> • 2 x aluminum fingers • 1 x screw kit 	HND-FIN-ALU-KIT
Fingertip Starting Kit	<ul style="list-style-type: none"> • 1 x Fingertip Holder Kit • 1 x V-Groove Fingertip Kit • 1 x Aluminum Fingertip Kit • 1 x hex key • 6 x dowel pins M2 X 6 • 8 x M3-0.5 X 8 screws 	HND-TIP-START-KIT
Flat Silicone Fingertip Kit	<ul style="list-style-type: none"> • 2 x flat rubber fingertips • 1 x screw kit <div style="border: 1px solid green; padding: 5px; margin-top: 10px;"> <p>Tip</p> <p>Silicone fingertips must be mounted on fingertip holders (HND-TIP-HLD-KIT).</p> </div>	HND-TIP-SLC-KIT
V-Groove Fingertip Kit	<ul style="list-style-type: none"> • 2 x V-groove aluminum fingertips • 1 x screw kit 	HND-TIP-VGR-KIT



Item	Description	Ordering Number
	<div style="border: 2px solid green; padding: 5px;"> <p>Tip</p> <p>V-groove fingertips must be mounted on fingertip holders (HND-TIP-HLD-KIT).</p> </div>	
Hand-E Fingertips Holder Kit	<ul style="list-style-type: none"> • 2 x fingertips holder • 1 x screw kit 	HND-TIP-HLD-KIT
Hand-E Fingertips Extender Kit	<ul style="list-style-type: none"> • 2 x fingertips extender • 1 x screw kit 	HND-TIP-EXT-KIT
10m Device Cable	10 m Robotiq device cable for power and communication. Straight M12 5-pins female on one side, single ended on the other, shielded	CBL-COM-2065-10-HF
USB to RS485 adapter	USB to RS485 adapter, can be used with device cable for USB connection	ACC-ADT-USB-RS485
Hand-E Screw Kit	<p>The screw kit contains:</p> <ul style="list-style-type: none"> • 4 x M5 screws • 4 x tooth lock washers 	HND-SCREW-KIT
End-Effector Coupling Kit	ISO 9409-1-50-4-M6 coupling for Adaptive Robot Grippers, with screws and tools for Gripper fixation and 1 m pigtail cable	GRP-CPL-062



To install Hand-E on a robot that has a different bolt pattern than part GRP-CPL-062 (ISO 9409-1-50-4-M6), you can use one of the following. The couplings and adapter plates listed below fit with both Hand-E and the 2-Finger Gripper.

Item	Description	Ordering Number
Blank coupling	Blank coupling for Adaptive Robot Grippers, with screws for Gripper fixation and 1 m pigtail cable	AGC-CPL-BLANK-002
ISO 9409-1-50-4-M6 coupling (cable-to-controller)	ISO 9409-1-50-4-M6 coupling for Robot Grippers with screws for Gripper fixation and 1 m pigtail cable	GRP-CPL-062
ISO 9409-1-31.5-4-M5 coupling	ISO 9409-1-31.5-4-M5 coupling for Adaptive Robot Grippers, with screws for Gripper fixation and 1 m pigtail cable	GRP-CPL-063
ISO 9409-1-40-4-M6 coupling	ISO 9409-1-40-4-M6 coupling for Adaptive Robot Grippers, with screws for Gripper fixation and 1 m pigtail cable	GRP-CPL-064
56-8M4-1D4 coupling	Coupling for 56 mm PCD ¹ with (8) M4 and (1) 4mm dowel pin, with screws for Adaptive Robot Grippers fixation and 1 m pigtail cable	AGC-CPL-065-002
56-6M4-1D6 coupling	Coupling for 56 mm PCD ¹ with (6) M4 and (1) 6mm dowel pin, with screws for Adaptive Robot Grippers fixation and 1 m pigtail cable	AGC-CPL-066-002
60-4Ø5-1D5 coupling	Coupling for 60 mm PCD ¹ with (4) M5 thread and (1) 5mm dowel pin, with screws for Adaptive Robot Grippers fixation and 1 m pigtail cable	AGC-CPL-067-002
63-6M6-2D6 coupling	Coupling for 63 mm PCD ¹ with (6) M6 and (2) 6mm dowel pins, with screws for Adaptive Robot Grippers fixation and 1 m pigtail cable	AGC-CPL-068-002
40-4M5-1D3 coupling	Coupling for 40 mm PCD ¹ with (4) M5 and (1) 3mm dowel pins, with screws for Adaptive Robot Grippers fixation and 1 m pigtail cable	AGC-CPL-070-002
31.5-4M4 coupling	Coupling for 31.5 mm PCD ¹ with (4) M4, with screws for Adaptive Robot Grippers fixation and 1 m pigtail cable	AGC-CPL-071-002
Adapter plate to 63-4M6-71-2D3	Wrist adapter plate for use with AGC-CPL-064-002. Interface to 63 mm PCD ¹ with (4) M6 screws and 71 mm PCD ¹ with (2) M3 dowel pins	AGC-APL-151-002
Adapter plate to 63-4M6-61_4-2D6	Wrist adapter plate for use with AGC-CPL-064-002. Interface to 63 mm PCD ¹ with (4) M6 screws and 61.4	AGC-APL-152-002



Item	Description	Ordering Number
	mm PCD 1 with (2) M6 dowel pins	
Adapter plate to 80-6M8-2D82D8	Wrist adapter plate for use with AGC-CPL-064-002. Interface to 80 mm PCD ¹ with (6) M8 screws and (2) M8 indexing pins	AGC-APL-153-002

¹Pitch Circle Diameter

Tip

For legacy part replacement visit the documentation archives and the appropriate manual or consult your Robotiq distributor.



8. Troubleshooting

8.1. Using the Robotiq User Interface (RUI)

Use the Robotiq User Interface to check that your gripper functions properly:

1. Install the Robotiq User Interface on a computer.
2. Connect your gripper to a computer USB port.
3. Send instructions to your gripper via the Robotiq User Interface. If this fails, check that all cables are connected to your gripper and to your computer.
4. Contact support@robotiq.com.

Info

For details on the Robotiq User Interface, see its Instruction Manual, available on robotiq.com/support.



9. Warranty and Patent

Robotiq warrants Hand-E against defects in material and workmanship for a period of one year from the date of reception when utilized as intended. Robotiq also warrants that this equipment will meet applicable specifications under normal use.

The warranty applies under the following conditions:

- Usage respects the operating and storage conditions specified in the **Environmental and Operating Conditions** section
- Proper installation of the Gripper specified in the **Installation** section and following subsections.
- Until one of these condition is reached:
 - 1 year
 - 5 000 000 cycle count¹
- Usage respects maintenance specified in the **Maintenance** section.
- Usage respects recommended payload and forces specified in the **Mechanical Specifications** section.

¹*Cycle count: One (1) cycle is defined as an object picking attempt, successful or not (open or closing onto an object, or closing on itself). It is calculated in the internal memory of the Hand-E Gripper.*

During the warranty period, Robotiq will repair or replace any defective Hand-E Gripper, as well as verify and adjust the Gripper free of charge if the equipment should need to be repaired or if the original adjustment is erroneous. If the equipment is sent back for verification during the warranty period and found to meet all published specifications, Robotiq will charge standard verification fees.

The unit is considered defective when at least one of the following conditions occurs:

- The Gripper fingers cannot close or open;
- The Gripper feedback necessary for the robot program is not accessible.

Parts that come into contact with the work piece and wearing parts such as the finger and fingertips are not covered by the warranty.

Caution

The warranty will become null and void if:

- The unit has been tampered with, repaired or worked on by unauthorized individuals.
- The warranty sticker has been removed (if present).
- The screws, other than as explained in this guide, have been removed.
- The unit has been opened other than as explained in this guide.
- Unit serial number has been altered, erased, or removed.
- Unit has been misused, neglected, or damaged by accident.

This warranty is in lieu of all other warranties expressed, implied, or statutory, including, but not limited to, the implied warranties of merchantability and fitness for a particular purpose. In no event shall Robotiq be liable for special, incidental, or consequential damages.



Robotiq shall not be liable for damages resulting from the use of the Hand-E, nor shall Robotiq be responsible for any failure in the performance of other items to which Hand-E is connected or the operation of any system of which the Gripper may be a part.



Exclusions

This warranty excludes failure resulting from: improper use or installation, normal wear and tear, accident, abuse, neglect, fire, water, lightning or other acts of nature, causes external to the Gripper or other factors beyond Robotiq's control. It also excludes all consumable parts, such as fingertips and their normal wear.

Robotiq reserves the right to make changes in the design or construction of any of its products at any time without incurring any obligation to make any changes whatsoever on units already purchased.



10. Harmonized Standards, Declarations and Certificates

10.1. EC declaration of incorporation



EC Declaration of Incorporation (Original)

In accordance with the EC Machinery Directive 2006/42/EC, Annex II, 1., Section B.

We, the manufacturer:

Robotiq Inc.
966 Chemin Olivier, Suite 500
Lévis, Québec, Canada, G7A 2N1

hereby declares, under sole responsibility, that the product:

Hand-E / Hand-E Gripper
All serial number
(and accessories)

complies with the following essential requirements of the European Directive 2006/42/EC on machinery:

1.1.2, 1.1.3, 1.1.5, 1.3.2, 1.3.3, 1.3.4, 1.5.1, 1.5.2, 1.5.3, 1.5.4, 1.5.8, 1.5.10, 1.5.11, 1.7.2.

The product is considered as partly completed machinery and has been evaluated in accordance with the following harmonised standards:

- *EN ISO 12100:2010*

The product must not be put into service until the final machinery into which it is to be incorporated has been declared in conformity with the provisions of the Directive 2006/42/EC, including amendments.

The manufacturer declares that the product complies with the following European Directives and harmonised standards:

- **2014/30/EU (EMC Directive)**
 - *EN 61000-6-2:2016*
 - *EN 61000-6-4:2007 + A1:2011*
- **2011/65/EU + 2015/863 (RoHS Directive)**
 - *EN 50581:2012*
- **2012/19/EU (WEEE Directive)**
 - *EN 50419:2005.*

The manufacturer also declares the use of these other technical standards, as far as applicable:

ISO 9409-1:2004
ISO 14539:2000.

Name and address of the person authorised to compile the relevant technical documentation:

Nicolas Tremblay, CEP, see manufacturer address.

The relevant technical documentation is compiled in accordance with part B of Annex VII of Directive 2006/42/EC and will be presented electronically by the manufacturer to competent national authorities, if required with a substantiated reason.

Signed in Lévis on November 7th, 2019

Louis-Alexis Allen Demers, ing., Eng., Ph. D.
Hardware Director



10.2. Applied standards

This section describes all applied harmonized standards for the design and production of the Robotiq Hand-E Gripper. Standards are applied where applicable, some points may not be applied if not applicable to this specific product. Conformity is not enforced by any laws, it is self-applied and the aim is to define normal safety and performance requirements for similar products.

Caution

Conformity of the product is only met if all instructions of this manual are followed. Among others: installation, safety measures and normal usage must be met.

The following standards have been applied:

- EN ISO 12100:2010 (Safety of machinery — General principles for design — Risk assessment and risk reduction)
- 2014/30/EU (EMC Directive)
 - EN 61000-6-2:2016
 - EN 61000-6-4:2007 + A1:2011
- 2011/65/EU + 2015/863 (RoHS Directive)
 - EN 50581:2012
- 2012/19/EU (WEEE Directive)
 - EN 50419:2005
- ISO 9409-1:2004 (Manipulating industrial robots — Mechanical interfaces — Part 1: Plates)
- ISO 14539:2000 (Manipulating industrial robots — Object handling with grasp-type grippers — Vocabulary and presentation of characteristics)



10.3. Ingress Protection Certificate



October 12th 2018

Purpose: Ingress Protection (IP67) – Hand-E Test Certificate

To whom it may concern,

This certificate is to attest that Ingress Protection (IP) tests were carried out by NTS Canada in the months of June and July 2018 on Hand-E units manufactured by Robotiq. No ingress of dust or water was observed inside the units after the tests. No insertion of the rod or induced damage was observed. No functional anomaly was noticed or reported by the Robotiq engineering representative on-site during the tests. This test certificate does not supersede the test report FTR0201898 Rev 00 issued by NTS Canada.

The acceptance status for the units tested is "PASS" for the following tests;

- Ingress protection against access to hazardous parts – Rod (code IP6X)
- Ingress protection against solid foreign objects - Dust (code IP6X)
- Ingress protection against immersion in water (code IPX7)

Sincerely yours,

**Jean-Pierre
Rioux**

Digitally signed by Jean-Pierre
Rioux
DN: cn=Jean-Pierre Rioux, o,
ou=NTS Canada Inc.,
email=Jean-
Pierre.Rioux@NTS.com, c=CA
Date: 2018.10.12 11:31:11 -0400

Jean-Pierre Rioux, P. Eng.
Lab Manager
National Technical Systems Canada inc.
2425 Industrial Blvd
Chambly, Quebec
J3L 4W3 Canada



11. Contact

www.robotiq.com

Contact Us

Phone

1-888-ROBOTIQ (762-6847)
(+1) 418-380-2788 Outside US and Canada

Technical support

Extension 3

Sales

Extension 2

Head office

Robotiq
966 chemin Olivier
Suite 500
Lévis, Québec
G7A 2N1
Canada



Where automation Pros come to share their know-how and get answers.

dof.robotiq.com

