



2F-85

2F-140

Original Notice

© 2018 Robotic Inc.

Robotiq 2F-85 & 2F-140
for OMRON TM Series Robots



Instruction Manual

LEAN 
ROBOTICS
robotiq.com | leanrobotics.org

Revisions	5
1. General Presentation	7
1.1. Gripper nomenclature	8
1.2. 2F-85 vs. 2F-140	9
1.3. Object picking	10
1.4. Setup and control	13
2. Safety	14
2.1. Warning	15
2.1.1. Risk assessment and final application:	15
2.2. Intended Use	16
3. Installation	17
3.1. Scope of Delivery	18
3.1.1. OMRON TM Kit	18
3.2. Required Tools and Equipment	18
3.3. Environmental and Operating Conditions	19
3.4. Mechanical Installation	19
3.4.1. Installing fingers on the Gripper	19
3.4.2. Installing the fingertips on the Gripper	21
3.4.3. Installing a Protector Kit on the Gripper Fingers	22
3.4.4. Installing the Gripper onto the robot	22
Single Gripper	22
Multiple Grippers	23
3.5. Electrical Setup	24
3.5.1. Pinout Interface	26
3.5.2. Coupling to controller	26
Single Gripper	28
Multiple Grippers	28
4. Control	30
4.1. Overview	30
4.2. Gripper Register Mapping	32
4.3. Robot Output Registers & Functionalities	33
4.4. Robot Input Registers & Status	36



4.5. Picking Features	39
4.5.1. Force control	39
4.5.2. Re-Grasp	44
4.5.3. Object detection	45
4.6. Control Logic	46
4.7. Modbus RTU Communication	47
4.7.1. Connection Setup	48
4.7.2. Read holding registers (FC03)	49
4.7.3. Read input registers (FC04)	50
4.7.4. Preset multiple registers (FC16)	51
4.7.5. Master read & write multiple registers FC23	52
4.7.6. Modbus RTU example	54
4.8. Control over OMRON TM	63
4.8.1. TM Robots Compatibility with Robotiq Grippers	63
4.8.2. Getting Started	63
4.8.3. TM Gripper Components	67
Installation	67
Gripper Button	74
Programming	76
SET Component	76
GRIP Component	78
RELEASE Component	79
CHANGEGRIPPER Component	81
Changing the Modbus Slave ID	83
<hr/> 5. User Interface	<hr/> 85
<hr/> 6. Specifications	<hr/> 86
6.1. Technical dimensions	87
6.1.1. Couplings	91
Blank coupling	91
Coupling for ISO 9409-1-50-4-M6	92
Coupling for ISO 9409-1-31.5-4-M5	93
Coupling for ISO 9409-1-40-4-M6	94
Coupling for PCD 56 with 8 x M4	95



Coupling for PCD 56 with 6 x M4	96
Coupling for PCD 60 with 4 x M5	97
Coupling for PCD 63 with 6 x M6	98
6.1.2. Fingertips	99
Flat silicone fingertip	100
Grooved fingertip	101
6.2. Mechanical specifications	102
6.2.1. Payload and force	103
Friction grasp and form-fit grasp	105
Maximum payload by grasp type	105
6.2.2. Equilibrium Line	106
6.2.3. Center of mass, tool center point and moment of inertia	107
6.2.4. Moment and force limits	109
6.3. Electrical specifications	110
7. Maintenance	111
7.1. Gripper cleaning	112
7.2. Periodic inspection	114
7.3. Fingertip replacement	115
7.4. Overhaul	116
8. Spare Parts, Kits and Accessories	117
9. Troubleshooting	120
10. Warranty and Patent	121
11. Contact	124
12. Harmonized Standards, Declarations and Certificates	125
12.1. Translation of original EC declaration of incorporation	125
12.2. Applied standards	126



Revisions

Robotiq may modify this product without notice, when necessary, due to product improvements, modifications or changes in specifications. If such modification is made, the manual will also be revised, see revision information. See the latest version of this manual online at support.robotiq.com.

Revision 2019/03/13

Updated mechanical specifications (section 6.2)

Revision 2018/12/06

First Publication of Instruction Manual



Copyright

© 2019 Robotiq Inc. All rights reserved.

This manual and the product it describes are protected by the Copyright Act of Canada, by laws of other countries, and by international treaties, and therefore may not be reproduced in whole or in part, whether for sale or not, without prior written consent from Robotiq. Under copyright law, copying includes translation into another language or format.

Information provided by Robotiq in this document is believed to be accurate and reliable. However, no responsibility is assumed by Robotiq for its use. There may be some differences between the manual and the product if the product has been modified after the edition date.

The information contained in this document is subject to change without notice.



1. General Presentation

The terms "Gripper", "Adaptive Gripper", "Robotiq Gripper", "Robotiq Adaptive Gripper", "2-Finger 85", "2-Finger 140", "2F-85" and "2F-140" used in the following manual all refer to the Robotiq 2-Finger Adaptive Robot Gripper. The Robotiq 2-Finger Adaptive Gripper has two versions, 85 and 140. The 2-Finger version will change finger opening dimensions, which will be 85 mm (2F-85) or 140 mm (2F-140). Both versions use the same base, installation and control will be exactly the same. The 2-Finger Gripper is a robotic peripheral that is designed for industrial applications. Its design makes it a unique robotic end-of-arm tool to quickly pick, place and handle a large range of objects of varying sizes and shapes.

Info

Unless specified, information in this manual applies to both the 85 and the 140 mm version of the 2-Finger Adaptive Robot Gripper.

Info

The following manual uses the metric system, unless specified, **all dimensions are in millimeters**.

Info

The following section presents the key features of the grasp-type gripper and must not be considered as appropriate to the gripper operation, each feature is detailed in the appropriate section of the manual. Safety guidelines must be read and understood before any operation is attempted with the grasp-type gripper.



1.1. Gripper nomenclature

The 2-Finger Gripper has two articulated fingers that each have two joints (two phalanges per finger), as shown in the figure below. The grasp-type gripper can engage up to five points of contact with an object (two on each of the phalanges plus the palm). The fingers are under-actuated, meaning they have fewer motors than the total number of joints. This configuration allows the fingers to automatically adapt to the shape of the object they grasp and it also simplifies the control of the grasp-type gripper.

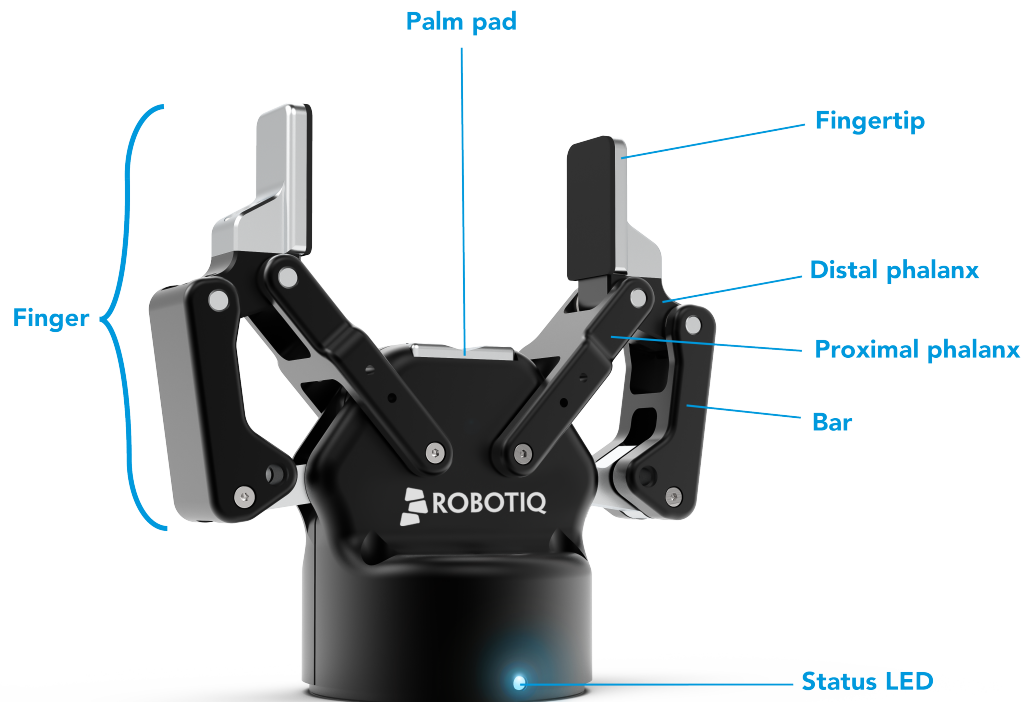

Fig. 1-1: Robotiq 2-Finger Adaptive Gripper.

Please refer to the for details on standard and optional parts.



1.2. 2F-85 vs. 2F-140

The 2-Finger Gripper comes with either 85 mm opening (2-Finger 85) or 140 mm opening (2-Finger 140) according to the figure below. The chassis will remain the same, only the fingers will change. Please refer to the **Mechanical Installation** section for installation instructions. Finger kits are available in the Spare Parts and Accessories section.

Info

Details on the 2-Finger 85 and 2-Finger 140 (dimensions and specifications) can be found in the **Specifications** section.

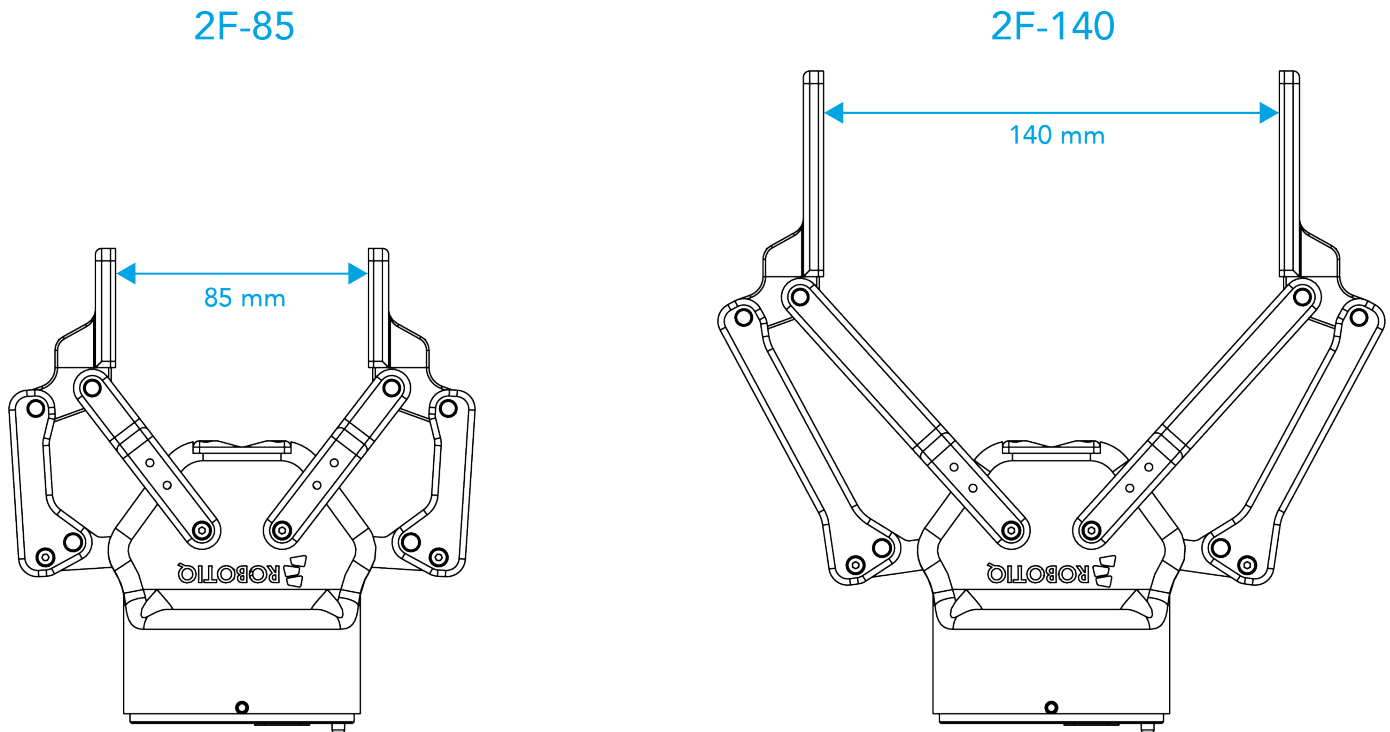

Fig. 1-2: The 2-Finger 85 and 140 mm versions.



1.3. Object picking

The 2-Finger Gripper has a single actuator for opening and closing the fingers, the fingers automatically adapt to the shape of the object manipulated.

Fingers will adopt either a parallel grasp or encompassing grasp as shown in the figure below.

Info

Closing or opening is done via the "Go to requested position" command and is input to the Gripper **Whether the fingers close to produce an encompassing or fingertip grasp is decided at the Gripper level automatically.** It will depend on:

- The object's geometry;
- The relative position of the object with respect to the Gripper.

In other words, picking the same object could result in either an encompassing or fingertip grasp based on an object's position and geometry.

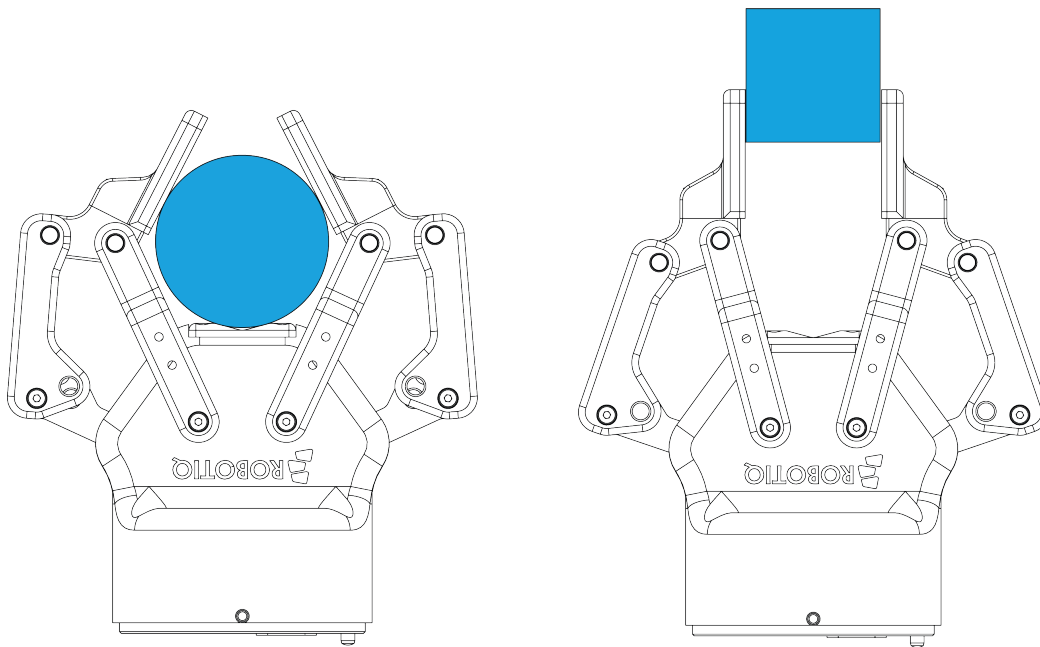

Fig. 1-3: 2-Finger parallel and encompassing grips.

Info

It is important to note that a fingertip grasp can only be performed when the fingers touch the object with the upper section of the distal phalanxes first. Inversely, for an encompassing grip, the fingers must touch the object with the proximal or the lower section of the distal phalanxes first. Also, to ensure stability, the object should be held against the Gripper palm while performing an encompassing grip. Refer to the figure below for a visual representation of the parallel and encompassing grasp regions on the distal phalanx of the 2-Finger Gripper.



The 2-Finger Adaptive Robot Gripper also allows for internal grasping. The fingers can pick hollow objects from the inside by applying pressure with the outside of the fingers. Refer to the figure below for a visual representation and to the **Picking Features** section for details on the possible position commands of your Gripper.

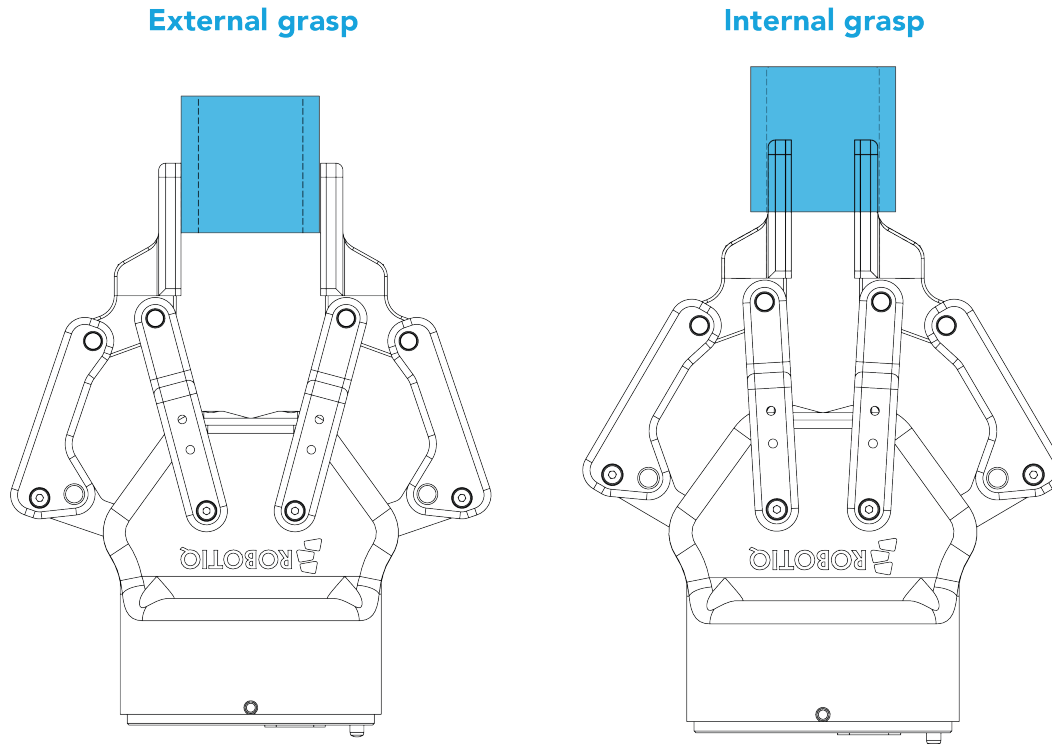

Fig. 1-4: Finger internal and external grasping.

The Gripper equilibrium line is the grasping region that separates the encompassing grasp from the parallel grip. When grasping an object close enough to the inside (palm) of the Gripper, the encompassing grasp will occur (unless the object size or shape is not adequate) and the fingers will close around the object.

If grasped above the equilibrium line, the same object will be picked up in a parallel grasp by the fingertips and the fingers will close with a parallel motion. The figure below shows the **encompassing grasp region**, the **equilibrium line**, and the **parallel grasp region** on the 2-Finger Adaptive Robot Gripper.

Info

The details of the equilibrium line relation between opening angle and the related position d can be found in the **Mechanical specifications** section.

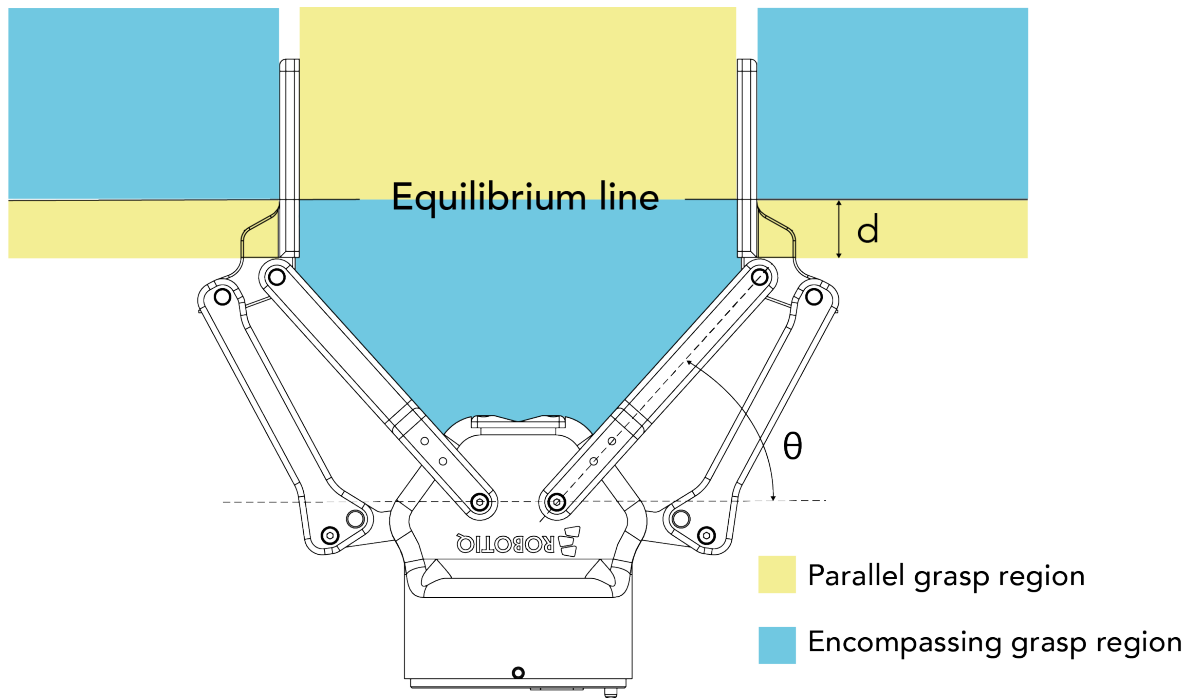

Fig. 1-5: Equilibrium line on the 2-Finger, shown with no fingertip pads.

Tip

Grasping an object that could be grasped by an encompassing grasp (a cylinder for example) on the equilibrium line is not recommended, as slight variations on the position will switch the grasp from parallel to encompassing and vice versa. Robot programming should be done so that the grasping mode will be predetermined.

1.4. Setup and control

The Gripper is powered and controlled directly via a single Device Cable that carries a 24V DC supply and Modbus RTU communication over RS-485, see Section 3.5 for wiring information and Section 4 for control of the Gripper (various software packages are available for control via various robot controllers).

Info

Robotiq Universal Controller is available when industrial communication protocols are required (other than Modbus RTU over serial).

Gripper Coupling is required for 2-Finger usage, the Coupling will provide mechanical and electrical connectivity. Please refer to the **Mechanical Installation** section for installation of the Coupling, to the **Specifications** section for technical drawings, and to the **Spare Parts, Kits and Accessories** section for available couplings.

The 2-Finger has an embedded object detection feature using indirect sensing methods. When picking an object via the "go to" command, the Gripper status will allow you to know if an object is picked or not via a simple object detection bit (0 or 1). When an object is detected, the Gripper will stop. If the object is being dropped, the Gripper will automatically close to keep the object until the "go to" command limit is attained. For details on object detection, see Control section.



2. Safety

Warning

The operator must have read and understood all of the instructions in the following manual before handling the Robotiq 2-Finger Adaptive Robot Gripper.

Caution

The term "operator" refers to anyone responsible for any of the following operations on the 2-Finger Adaptive Robot Gripper:

- Installation
- Control
- Maintenance
- Inspection
- Calibration
- Programming
- Decommissioning

This documentation explains the various components of the 2-Finger and general operations regarding the whole life-cycle of the product from installation to operation and decommissioning.

The drawings and photos in this documentation are representative examples and differences may exist between them and the delivered product.



2.1. Warning

Caution

Any use of the Gripper in noncompliance of these warnings is inappropriate and may cause injury or damage.

Warning

- The Gripper needs to be properly secured before operating the robot.
- Do not install or operate a Gripper that is damaged or lacking parts.
- Never supply the Gripper with an alternative current source.
- Make sure all cord sets are always secured at both ends, at the Gripper and at the robot.
- Always satisfy the recommended keying for electrical connections.
- Be sure no one is in the robot and/or Gripper path before initializing the robot's routine.
- Always satisfy the Gripper payload.
- Set the Gripper pinch force and speed accordingly, based on your application.
- Keep fingers and clothes away from the Gripper while the power is on.
- Do not use the Gripper on people or animals.
- For welding applications, make sure there are no Gripper parts on the ground path of the welding power source.

Any use of the Gripper in noncompliance of these warnings is inappropriate and may cause injury or damage.

2.1.1. Risk assessment and final application:

The Robotiq 2-Finger Adaptive Gripper is meant to be used on an industrial robot. The robot, Gripper and any other equipment used in the final application must be evaluated with a risk assessment. It is the robot integrator's duty to ensure that all local safety measures and regulations are respected. Depending on the application, there may be risks that need additional protection/safety measures, for example, the work-piece the Gripper is manipulating may be inherently dangerous to the operator.



2.2. Intended Use

The Gripper unit is designed for grasping and temporarily securing or holding objects.

Caution

The Gripper is NOT intended for applying force against objects or surfaces.

The product is intended for installation on a robot or other automated machinery and equipment.

Info

Always comply with local and/or national laws, regulations and directives on automation safety and general machine safety.

The unit may be used only within the range of its technical data. Any other use of the product is deemed improper and unintended use. Robotiq will not be liable for any damages resulting from any improper or unintended use.



3. Installation

The following subsections will guide you through the installation and general setup of your Robotiq 2-Finger Adaptive Robot Gripper.

- The **Scope of Delivery** section
- The **Required Tools and Equipment** section
- The **Environmental and Operating Conditions** section
- The **Mechanical Installation** section
- The **Electrical Setup** section

Warning

Before installing:

- Read and understand the safety instructions related to the 2-Finger Adaptive Robot Gripper.
- Verify your package according to the Scope of delivery and your order.
- Have the required parts, equipment and tools listed in the requirements readily available

Warning

When installing:

- Satisfy the environmental conditions.
- Do not operate the Gripper, or even turn on the power supply, before it is firmly anchored and the danger zone is cleared. The fingers of the Gripper may move and cause injury or damage.



3.1. Scope of Delivery

3.1.1. OMRON TM Kit

Robotiq 2F-85 Adaptive Gripper	Robotiq 2F-140 Adaptive Gripper
<ul style="list-style-type: none"> • 1x 2F-85 Basic Gripper Unit (with Flat Silicone Fingers) • 1x End Effector Coupling for Bolt Pattern ISO 9409-1-50-4-M6 (with 1 m Pigtail Cable) • 1 x 10 m Robotiq Device Cable • 1x RS485 to RS232 Converter • 1x Screw Kit for Fixing End Effector Coupling on TM Robots • 1x RS485 to USB Converter (for troubleshooting or Slave Address ID Change on a PC) 	<ul style="list-style-type: none"> • 1x 2F-140 Basic Gripper Unit (with Flat Silicone Fingers) • 1x End Effector Coupling for Bolt Pattern ISO 9409-1-50-4-M6 (with 1 m Pigtail Cable) • 1 x 10 m Robotiq Device Cable • 1x RS485 to RS232 Converter • 1x Screw Kit for Fixing End Effector Coupling on TM Robots • 1x RS485 to USB Converter (for troubleshooting or Slave Address ID Change on a PC)

3.2. Required Tools and Equipment

The following tools are required to install the 2-Finger Adaptive Gripper:

- 4 mm hex key to mount the Gripper onto its coupling.
- Metric hex key according to your coupling to mount the coupling onto the robot.

Optional tools if installing finger kits: **AGC-FIN-KIT-085** or **AGC-FIN-KIT-140**:

- 2 mm hex key

Optional tools if installing other fingertips: **AGC-TIP-204-085**, **AGC-TIP-205-085**, **AGC-TIP-420-140**, **AGC-TIP-420-140**

- 4 mm hex key

The following parts are required for setup :

- Power supply (see below).
- Fuse (if applicable), see information below.
- Emergency stop is not provided, but its use is strongly advised.

The Gripper needs to be supplied by a DC voltage source. This power supply is not included with the Gripper. Required power supply must match the Robotiq device. The following table shows the specifications with regards to the power supply required to operate the Gripper and the optional Robotiq Controller.

Table 3-1: 2-Finger power supply requirements.

Info

1 Suggested fuse is a: Phoenix Contact # 0916605 2 A thermal, use AWG #20 wiring.

Warning



If your power supply could exceed the specified regulation, over-voltage protection is required.

Robotiq recommends the use of the following power supplies:

Tip

Optional Robotiq Universal Controller can use the same power supply.

3.3. Environmental and Operating Conditions

CONDITION	VALUE
Minimum storage/transit temperature	-30°C [-22°F]
Maximum storage/transit temperature	60°C [140°F]
Minimum operating temperature	-10°C [14°F]
Maximum operating temperature	50°C [122°F]
Humidity (non-condensing)	20-80% RH
Vibration	< 0.5G
Other	<ul style="list-style-type: none"> • Free from dust, soot or fluids • Free from corrosive liquids or gases • Free from explosive liquids or gases • Free from powerful electromagnetic interference

Table 3-2: Environmental and operating conditions of the 2-Finger Adaptive Gripper.

3.4. Mechanical Installation

3.4.1. Installing fingers on the Gripper

Depending on your order, you may or may not have fingers already mounted on the Gripper. The first step of installation should be to install the fingers. Refer to the figure below for finger placement. To do so :

1. Align fingers with chassis axes. To do so, the slot on the finger bar should be aligned correctly with the corresponding chassis axis.
2. Insert the finger shaft in the finger bar bracket hole and through the chassis axis (top hole is for parallel locking while bottom hole is for finger installation)..
3. Apply medium strength threadlocker on the provided screws, align the finger bar and fasten to the chassis/chassis axis.



PROVIDED PARTS:

	AGC-FIN-KIT-85	AGC-FIN-KIT-140
①	85 mm fingers	140 mm fingers
②	5 mm stainless steel finger shaft	
③	Optional parallel locking kit with one 5 mm stainless steel finger shaft and two M3 X 5 mm socket low head screw	
④	M3 X 5 mm socket low head screws	

TOOLS YOU NEED:

- 3 mm hex key
- Medium strength threadlocker

EXPLODED VIEW SHOWN WITH ONE 85 MM FINGER AND ONE 140 MM.

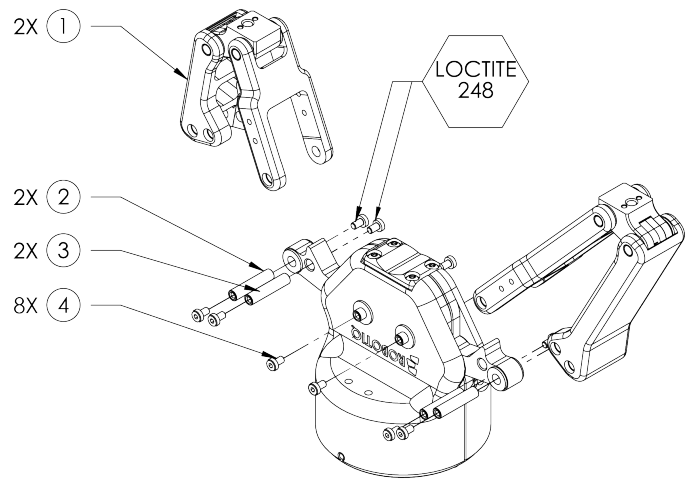

Fig. 3-1: 2-Finger Adaptive Gripper installation.

3.4.2. Installing the fingertips on the Gripper

Depending on your options, you may have fingertips to install. The second step of the installation should be to install the fingertips. To do so:

1. Align the fingertip indexing pins with the finger dowel holes.
2. Insert the M5 X 10 low head cap screws and screw on after applying low strength threadlocker.

PROVIDED PARTS:

	AGC-TIP-XXX-002	AGC-TIP-XXX-140
①	(85 mm fingertip option)	(140 mm fingertip option)
②	M5 X 10 mm head cap screw	
③	M2 X 6 mm indexing pins (M6 tolerance)	

TOOLS YOU NEED:

- 4 mm hex key
- Low strength threadlocker

Quantity shown for a single kit (1 pad)

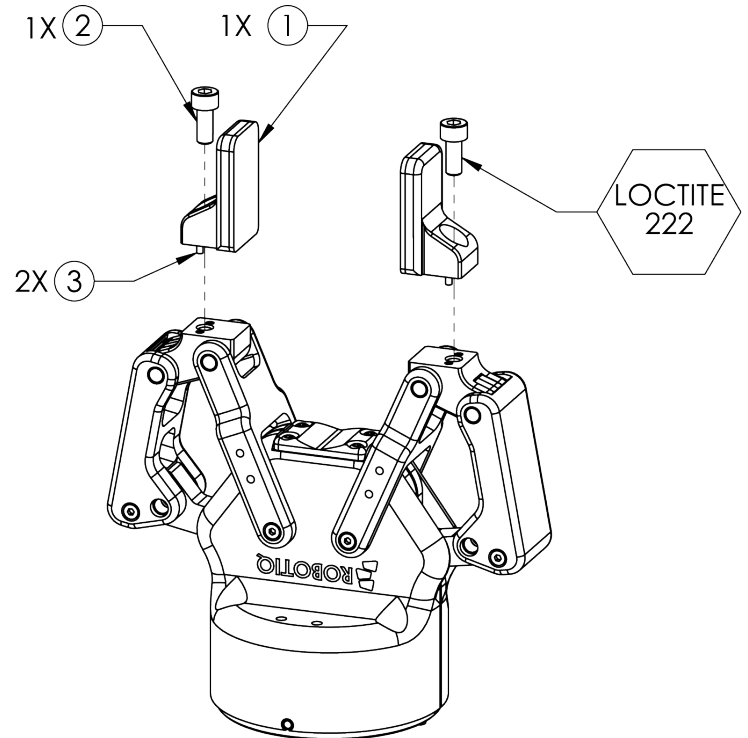

Fig. 3-2: Installing the fingertips on the Gripper



3.4.3. Installing a Protector Kit on the Gripper Fingers

An optional protector kit (AGC-PRO-KIT-V4) can be ordered to cover the fingers of the 2F-85 and therefore protect users and assets against pinch points.

You can install them using eight (8) M3 screws.

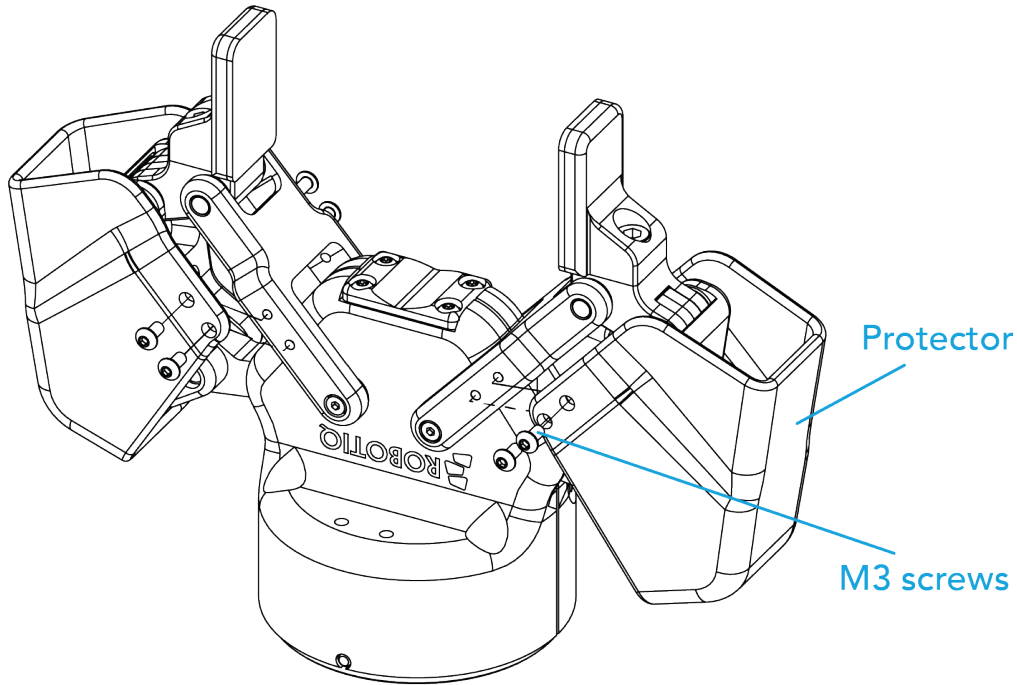

Fig. 3-3: Protector Kit Installation

3.4.4. Installing the Gripper onto the robot

Single Gripper

You must use a coupling to attach the Gripper to the robot.

Here are the steps to follow to mount the Gripper on the robot (exploded view in the figure below). Note that all screws must be locked in place using medium strength threadlocker.

1. Screw the coupling to the robot wrist; align properly with the dowel pin
2. Fasten the Gripper to the coupling

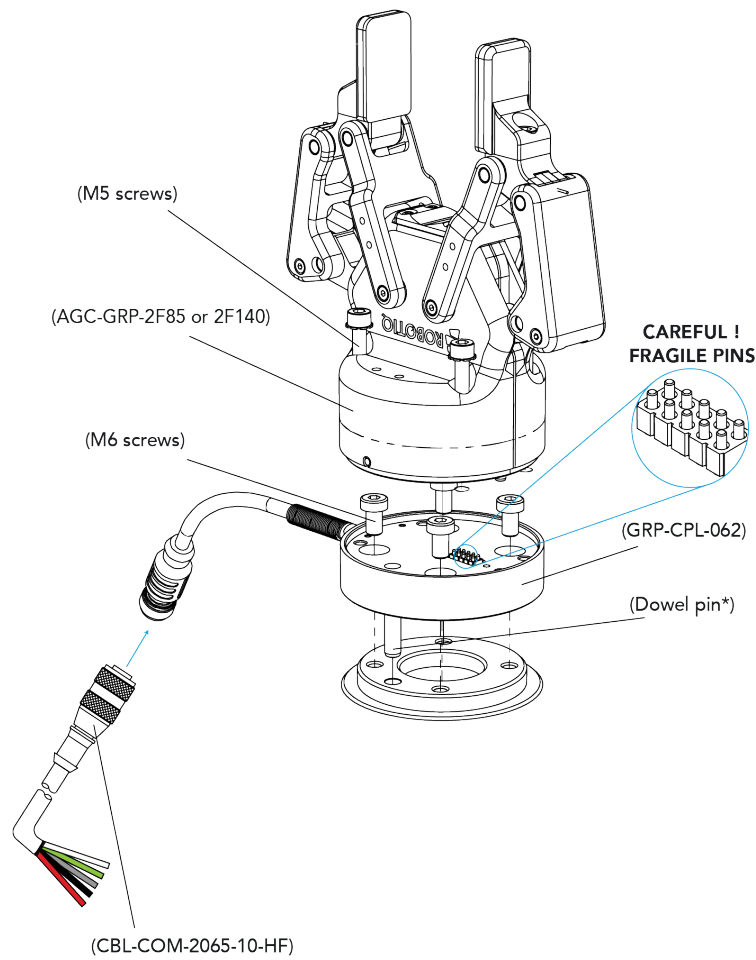

Fig. 3-4: Installing a Gripper on the robot wrist

Multiple Grippers

When installing multiple grippers on one robot, every gripper must have its own coupling.

1. Install a mounting plate (not provided) first on the robot arm (AGC-APL-159-02).
2. Mount the gripper couplings on the mounting plate using the provided M6 X 10 mm screws.
3. Mount the grippers onto their coupling using the provided M5 X 35 mm screws.



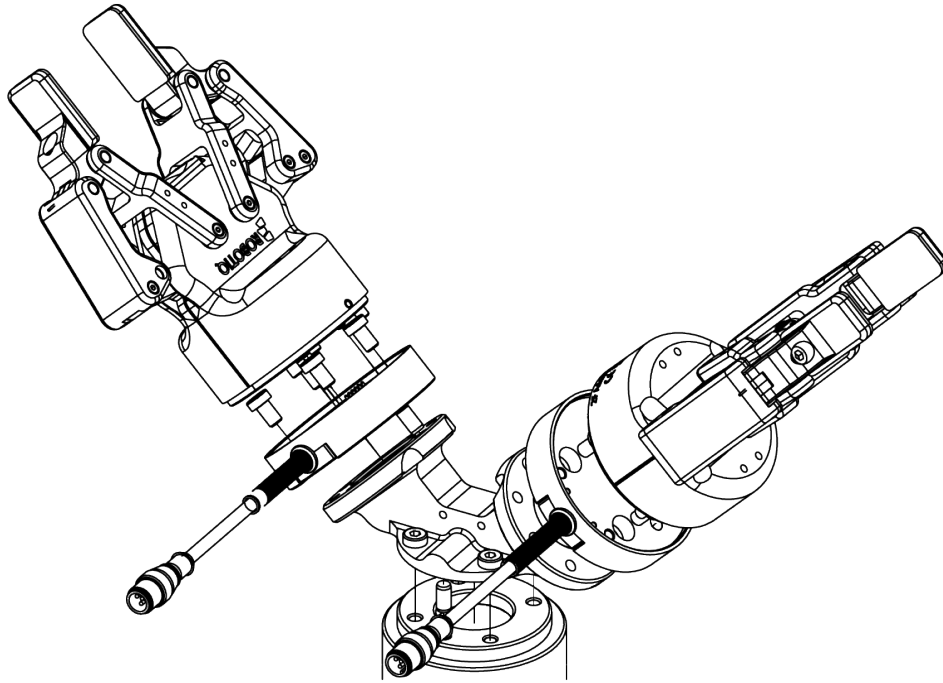

Fig. 3-5: Exploded View of a Dual Gripper Setup

Fig. 3-6: Exploded view of a dual gripper setup

3.5. Electrical Setup

Power and communication are established with the 2-Finger Adaptive Robot Gripper via a single Device Cable. The Device Cable provides a 24V power supply to the Gripper and enables serial RS485 communication to the robot controller. An optional Robotiq Universal Controller may be used between the Gripper and the network / robot controller if fieldbus communication is required.

Info

RS485 signals (485+, 485- and 485 GND) are isolated from the main 24V power supply. 4 GND can be connected to any other ground reference as long as the voltage potential between the grounds does not exceed 250V. Grounding reference is at the user's discretion.

Gripper grounding is optional and is done via the robot ground. The coupling indexing pin (dowel) is the ground connector. Gripper coupling, chassis and proximal phalanx are linked as illustrated in the figure below. They link through the coupling indexing pin to the robot ground. Proximal bars, distal phalanx, fingertip base and fingertips are isolated.

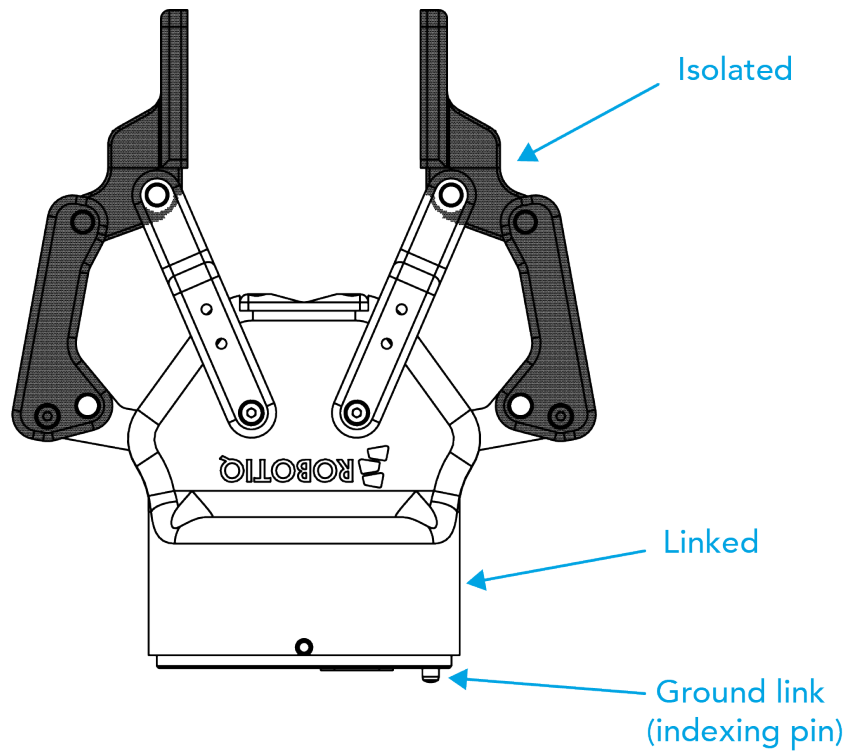
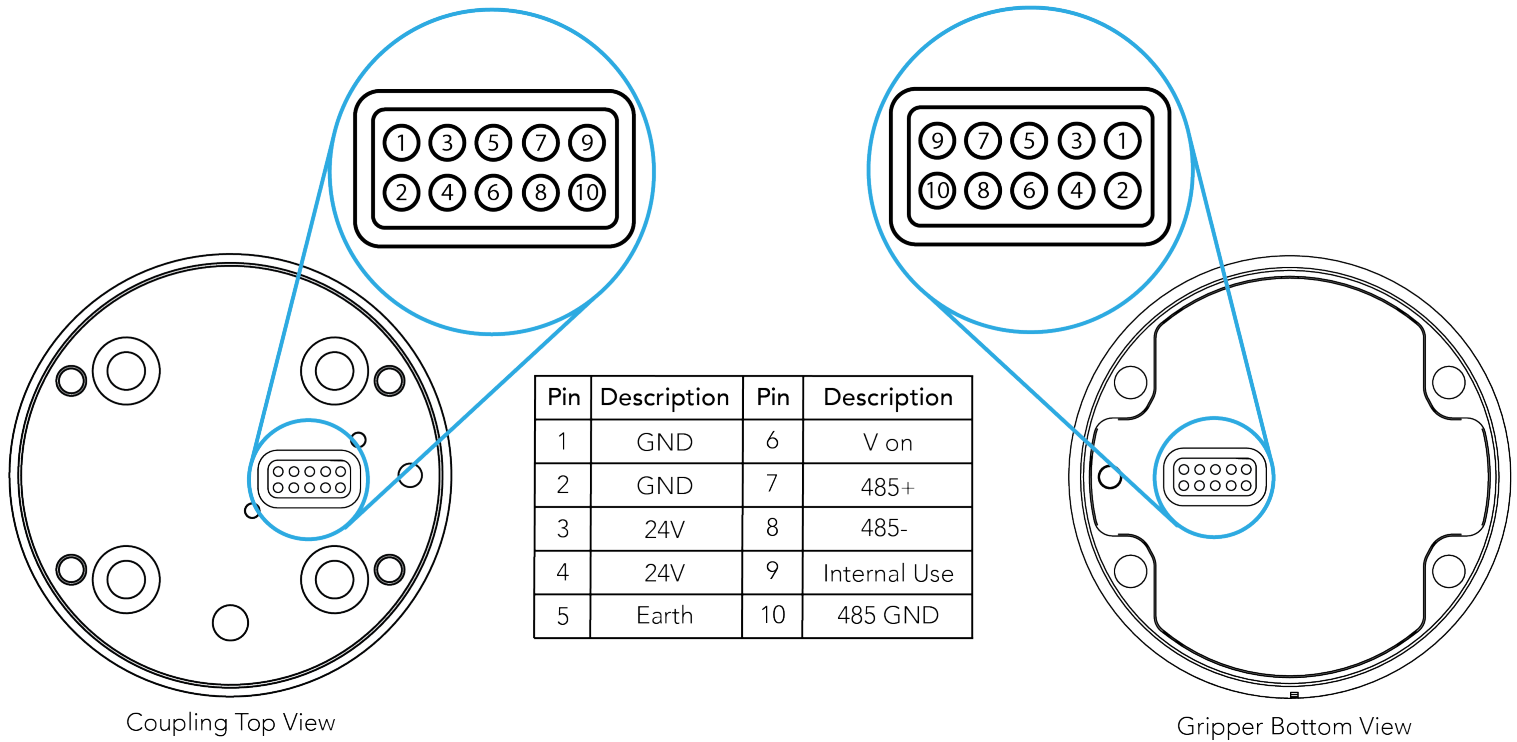

Fig. 3-7: Robotiq 2-Finger electrical isolation / grounding.



3.5.1. Pinout Interface

The Gripper interfaces with its coupling via a 10-spring pin connector located on its outer surface.



Info

The coupling used in the figure above is used for reference only and corresponds to bolt pattern ISO 9409-1-50-4-M6.

3.5.2. Coupling to controller

If a Robotiq Universal Controller is used, please refer to the Robotiq Universal Controller manual. The figure below represents the wiring schematic of the 2-Finger with device cable, power supply, fuse (please refer to the **Required Tools and Equipment** section) and grounding.



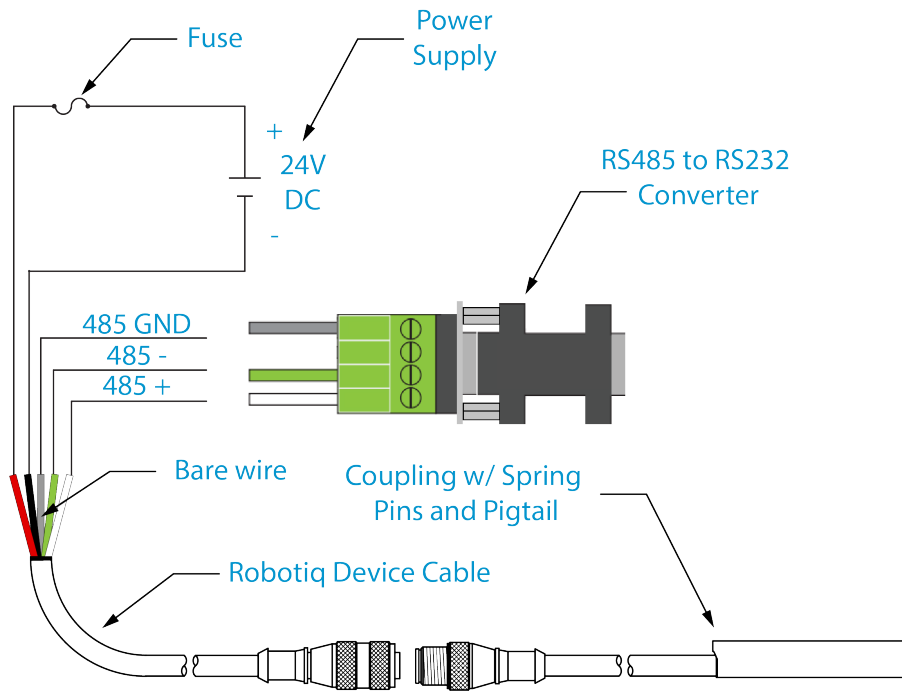
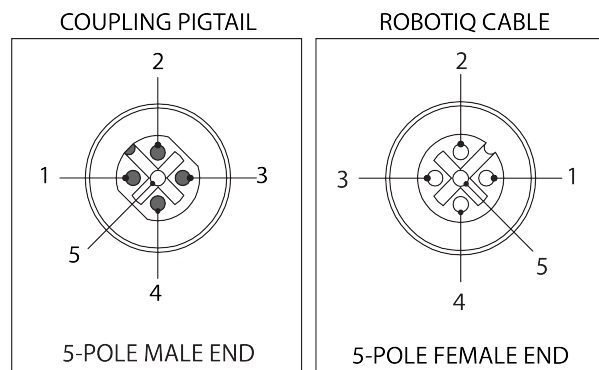

Fig. 3-8: Pigtail cable and device cable wiring schematic.
 Fig. 3-9: Robotiq 2-Finger with pigtail cable and device cable wiring schematic.

Warning

Use proper cabling management. Be sure to have enough forgiveness in the cabling to allow movement of the Gripper along all axes without pulling out the connectors. Always protect the controller-side (robot side) connector of the cable with a strain relief cable clamp.

The figure below represents the 2-Finger pigtail connector from the coupling (AGC-CPL-XXX), device cable - robot side (CBL-COM-2065-XX) and their associated pinout.



PIN	END OF CABLE COLOR	SIGNAL
1.	(SHIELD)	RS485 GND
2.	RED	24 V
3.	BLACK	GND
4.	WHITE	RS485 +
5.	GREEN	RS485 -

Fig. 3-10: Pinout of the 2-Finger pigtail and device cable.



If additional cable is used, suggested cable specifications are as follows:

Power supply, fusing:

Single Gripper

Connect the white, green and bare wires to the Robotiq RS485 to RS232 signal converter (ACC-ADT-RS232-RS485) as shown in the figure below.

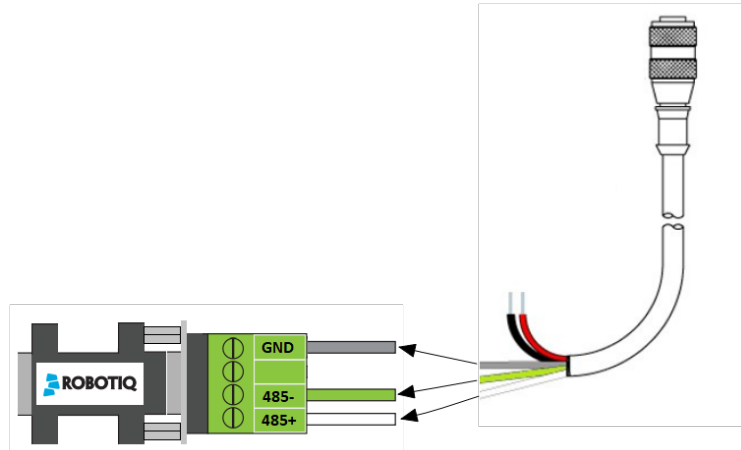

Fig. 3-11: Gripper Cable to RS485/RS232 Converter

Also connect the red (24V) and black (0V) wires in the controller according to the figure below.

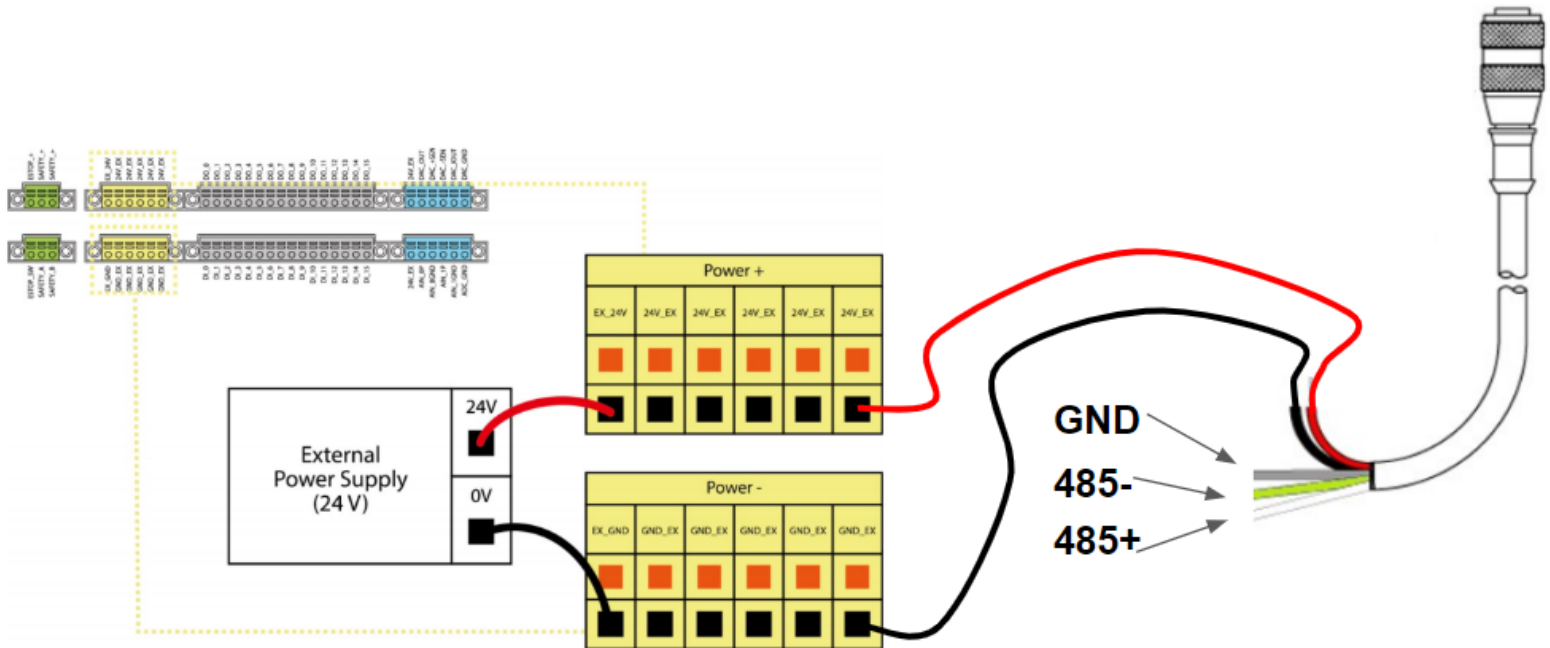

Fig. 3-12: Gripper Cable to Terminal Connector on the Controller

Multiple Grippers

It is possible to connect multiple grippers on the same robot. Only one RS485 to RS232 converter (ACC-ADT-RS232-RS485) must be used. Use M12 splitters (ACC-SPLIT-M12-2:1) to connect all the grippers pigtails to one 10m cable (CBL-COM-2065-10-HF) that connects to the RS485 to RS232 converter.



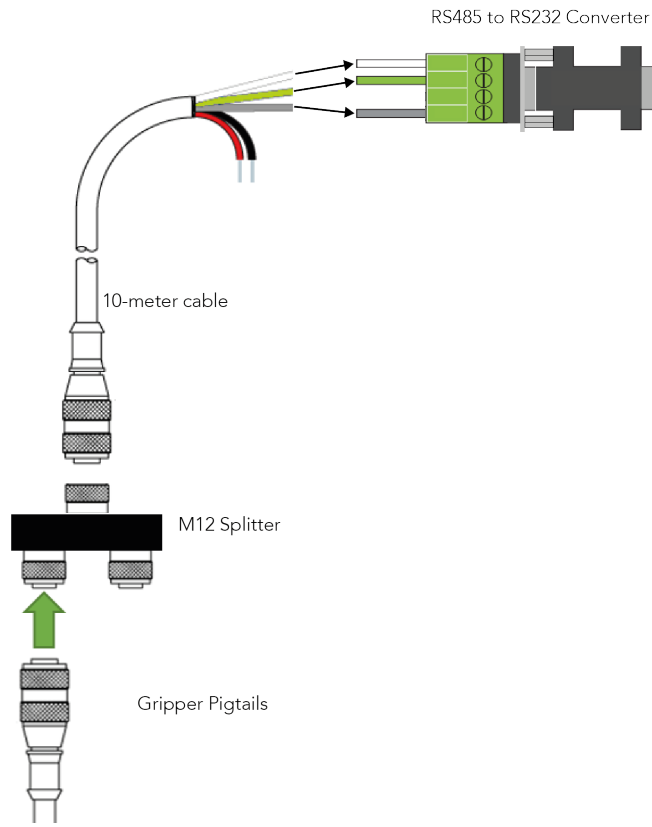

Fig. 3-13: Multiple grippers wiring



4. Control

Info

Unless specified, all values in this section are hexadecimal values.

4.1. Overview

Tip

Robotiq suggests using the Robotiq User Interface test software to explore the various features of the Gripper, like object detection and force control.

Since the Robotiq 2-Finger has its own embedded controller, high-level commands, such as "Go to requested position" are used to control it.

Info

The operator can:

- Control force, speed and position of the Gripper fingers.
- Finger movement is always synchronized, movement is initiated via a single "Go to requested position" command.
- Parallel or encompassing grasp is done automatically.
- A built in object detection feature is available, the user can be notified after an object is picked once the "Go to" command has been initiated.
- Engage directional (open or close) auto-release for emergencies.

Control using registers

The Gripper has an internal memory that is shared with the robot controller. One part of the memory is for the robot output; **gripper functionalities**. The other part of the memory is for the robot input; **gripper status**. Two types of actions can then be done by the robot controller:

1. Write in the **robot output** registers to activate **functionalities**;
2. Read in the **robot input** registers to get the **status** of the Gripper.

The **Gripper Register Mapping** section will map the different registers used to control the Gripper or to read its status while the **Robot Output Registers & Functionalities** section will detail the output (write) register functions, and the **Robot Input Registers & Status** section will detail the input (read) register status. The figure below is a representation of the memory and the control logic of the Gripper.



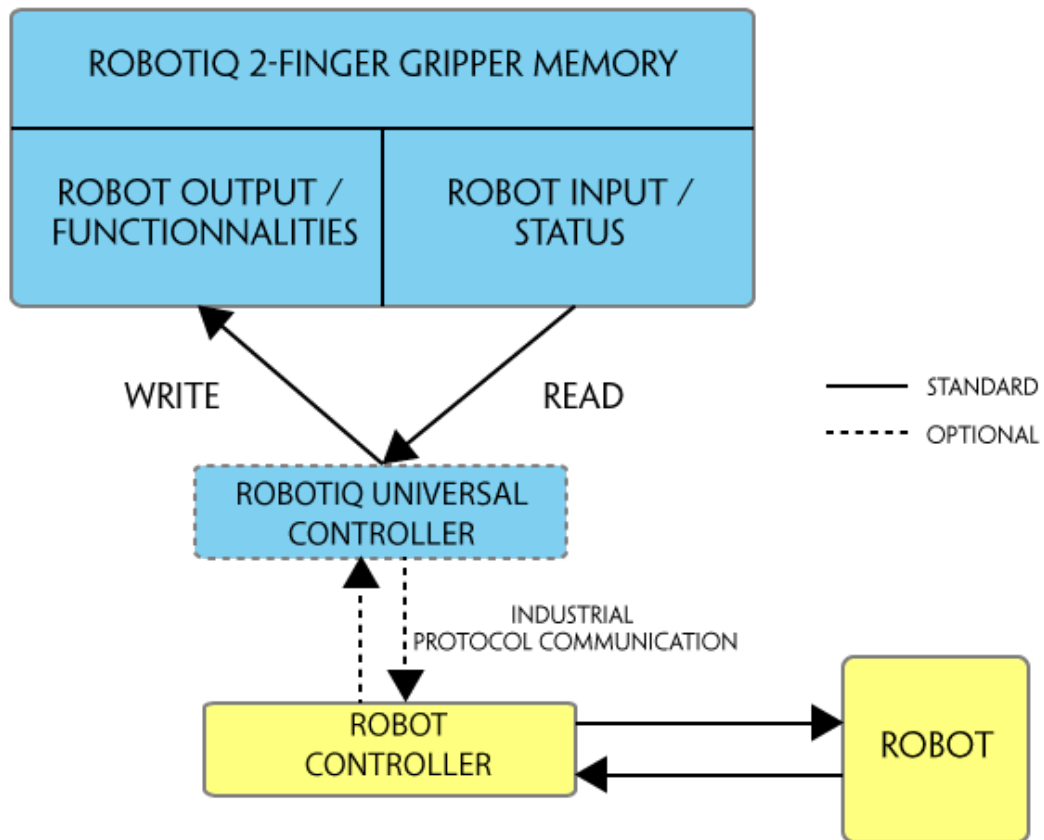

Fig. 4-1: 2-Finger control logic overview

4.2. Gripper Register Mapping

Register mapping

Caution

Byte numeration **starts at zero** and not at 1 for the functionalities and status registers.

Register	Robot Output / Functionalities	Robot Input / Status
Byte 0	ACTION REQUEST	GRIPPER STATUS
Byte 1	RESERVED	RESERVED
Byte 2	RESERVED	FAULT STATUS
Byte 3	POSITION REQUEST	POS REQUEST ECHO
Byte 4	SPEED	POSITION
Byte 5	FORCE	CURRENT
Byte 6 to 15	RESERVED	RESERVED

Table 4-1: Registers of the 2-Finger Gripper.



4.3. Robot Output Registers & Functionalities

Register: ACTION REQUEST

Address: Byte 0

Bits	7	6	5	4	3	2	1	0
Symbols	Reserved		rARD	rATR	rGTO	Reserved		rACT

rACT: First action to be made prior to any other actions, **rACT** bit will activate the Gripper. Clear **rACT** to reset the Gripper and clear fault status.

- 0x0 - Deactivate Gripper.
- 0x1 - Activate Gripper (must stay on after activation routine is completed).

Warning

When setting **rACT** to one, the Gripper will begin movement to complete its auto-calibration feature.

Info

Power loss will set **rACT**; **rACT** bit must then be cleared, then set to allow operation of the Gripper.

Caution

rACT bit must stay on afterwards for any other action to be performed.

rGTO: The "Go To" action moves the Gripper fingers to the requested position using the configuration defined by the other registers, **rGTO** will engage motion while byte 3, 4 and 5 will determine aimed position, force and speed. The only motions performed without the **rGTO** bit are activation and automatic release routines.

- 0x0 - Stop.
- 0x1 - Go to requested position.

rATR: Automatic Release routine action slowly opens the Gripper fingers until all motion axes reach their mechanical limits. After all motion is completed, the Gripper sends a fault signal and needs to be reactivated before any other motion is performed. The **rATR** bit overrides all other commands excluding the activation bit (**rACT**).

- 0x0 - Normal.
- 0x1 - Emergency auto-release.

Caution

The automatic release is meant to disengage the Gripper after an emergency stop of the robot.

The automatic release is not intended to be used under normal operating conditions.

Automatic release will require **rACT** to be cleared (**rACT** == 0) then set (**rACT** == 1).



rARD: Auto-release direction. When auto-releasing, **rARD** commands the direction of the movement. The **rARD** bit should be set prior to or at the same time as the **rATR** bit, as the motion direction is set when the auto-release is initiated.

- 0x0 - Closing auto-release
- 0x1 - Opening auto-release

Register: **GRIPPER OPTIONS**

Address: **Byte 1**

Register: **GRIPPER OPTIONS 2**

Address: **Byte 2**

Bits	7	6	5	4	3	2	1	0
Symbol	Reserved							

Register: **POSITION REQUEST**

Address: **Byte 3**

Bits	7	6	5	4	3	2	1	0
Symbol	rPR							

This register is used to set the target position for the Gripper's fingers. The positions 0x00 and 0xFF correspond respectively to the fully opened and fully closed mechanical stops. For detailed finger trajectory, please refer to the **Specifications** section.

- 0x00 - Open position, with 85 mm or 140 mm opening respectively
- 0xFF - Closed
- Opening / count: 0.4 mm (for 85 mm stroke) and 0.65 mm (for 140 mm stroke)

Info

The activation feature of the Robotiq Adaptive Gripper will allow the Gripper to adjust to any fingertips. No matter what is the size and shape of the fingertips used, 0 will always be fully opened and 255 fully closed, with a quasi-linear relationship between 0 and 255.

Register: **SPEED**

Address: **Byte 4**



Bits	7	6	5	4	3	2	1	0
Symbol	rSP							

This register is used to set the Gripper closing or opening speed in real time, however, **setting a speed will not initiate a motion.**

- 0x00 - Minimum speed
- 0xFF - Maximum speed

Register: **FORCE**

Address: **Byte 5**

Bits	7	6	5	4	3	2	1	0
Symbol	rFR							

The force setting defines the final gripping force for the Gripper. The force will fix the maximum current sent to the motor while in motion. If the current limit is exceeded, the fingers stop and trigger an object detection notification. Please refer to the **Robot Input Registers & Status** section for details on force control.

- 0x00 - Minimum force
- 0xFF - Maximum force

Info

Register bytes 6 to 15 are reserved and should be set to zero.



4.4. Robot Input Registers & Status

Register: GRIPPER STATUS

Address: Byte 0

Bits	7	6	5	4	3	2	1	0	
Symbol s	gOBJ		gSTA		gGTO		Reserved		gACT

gACT: Activation status, echo of the **rACT** bit (activation bit).

- 0x0 - Gripper reset.
- 0x1 - Gripper activation.

gGTO: Action status, echo of the **rGTO** bit (go to bit).

- 0x0 - Stopped (or performing activation / automatic release).
- 0x1 - Go to Position Request.

gSTA: Gripper status, returns the current status & motion of the Gripper fingers.

- 0x00 - Gripper is in reset (or automatic release) state. See Fault Status if Gripper is activated.
- 0x01 - Activation in progress.
- 0x02 - Not used.
- 0x03 - Activation is completed.

gOBJ: Object detection status, is a built-in feature that provides information on possible object pick-up. Ignore if **gGTO** == 0.

- 0x00 - Fingers are in motion towards requested position. No object detected.
- 0x01 - Fingers have stopped due to a contact while opening before requested position. Object detected opening.
- 0x02 - Fingers have stopped due to a contact while closing before requested position. Object detected closing.
- 0x03 - Fingers are at requested position. No object detected or object has been loss / dropped.

Caution

In some circumstances object detection may not detect an object even if it is successfully grasped. For example, picking up a thin object in a fingertip grasp may be successful without object detection occurring. For such reasons, use this feature with caution. In these applications when the "Fingers are at requested position" status of register gOBJ, this is sufficient to proceed to the next step of the routine.

Tip

Checking for the correct position of the fingers (byte 4), **as well as** object detection (byte 0, bit 6 & 7) before proceeding to the next step of a routine is a more reliable method than object detection or finger position alone.



Register: **RESERVED**Address: **Byte 1**

Bits	7	6	5	4	3	2	1	0
Symbol	Reserved							

Register: **FAULT STATUS**Address: **Byte 2**

Bits	7	6	5	4	3	2	1	0
Symbols	kFLT			gFLT				

gFLT: Fault status returns general error messages that are useful for troubleshooting. Fault LED (red) is present on the Gripper chassis, LED can be blue, red or both and be solid or blinking.

- 0x00 - No fault (LED is blue)
- Priority faults (LED is blue)
 - 0x05 - Action delayed, activation (reactivation) must be completed prior to performing the action.
 - 0x07 - The activation bit must be set prior to action.

Minor faults (LED continuous red)

- 0x08 - Maximum operating temperature exceeded, wait for cool-down.
- 0x09 No communication during at least 1 second.

Major faults (LED blinking red/blue) - Reset is required (rising edge on activation bit **rACT** needed).

- 0x0A - Under minimum operating voltage.
- 0x0B - Automatic release in progress.
- 0x0C - Internal fault; contact support@robotiq.com.
- 0x0D - Activation fault, verify that no interference or other error occurred.
- 0x0E - Overcurrent triggered.
- 0x0F - Automatic release completed.

Info

While booting, status LED will be solid blue / red.

kFLT : See your optional Controller Manual (input registers & status).



Register: **POSITION REQUEST ECHO**

Address: **Byte 3**

Bits	7	6	5	4	3	2	1	0
Symbol	gPR							

gPR: Echo of the requested position for the Gripper, value between 0x00 and 0xFF.

- 0x00 - Full opening.
- 0xFF - Full closing.

Register: **POSITION**

Address: **Byte 4**

Bits	7	6	5	4	3	2	1	0
Symbol	gPO							

gPO: Actual position of the Gripper obtained via the encoders, value between 0x00 and 0xFF.

- 0x00 - Fully opened.
- 0xFF - Fully closed.

Register: **CURRENT**

Address: **Byte 5**

Bits	7	6	5	4	3	2	1	0
Symbol	gCU							

gCU: The current is read instantaneously from the motor drive, value between 0x00 and 0xFF, approximate current equivalent is 10 * value read in mA.

Tip

Built-in features like object detection and force control use the finger's electrical current readings. The user does not need to create these features.



4.5. Picking Features

As stated in previous sections, object picking is done via a simple "Go To" command, **rGTO** bit calls for movement, while **rPR** byte is the aimed position, **rSP** and **rFR** will be the desired speed and force settings respectively. This section describes key features in object picking applications:

- Force control
- Re-grasp
- Object detection

4.5.1. Force control

The 2-Finger Gripper gripping force is controlled via the **rFR** byte (refer to the **Gripper Register Mapping** section). The Gripper behavior will change according to the **rFR** force requested.

- **rFR = 0** : Very fragile objects or deformable objects mode
 - Lowest force
 - Re-grasp feature is off
- **1 rFR 127** : Solid & fragile objects
 - Low torque mode
 - Re-grasp feature is on
- **128 rFR 255** : Solid & strong objects
 - High torque mode
 - Re-grasp feature is on

The table below shows the expected applied force according to the payload material hardness, speed setting **rSP** and force setting **rFR**. All tests were done with the 2-Finger Gripper with firmware GC3-1.3.9. Data was obtained with a Load Cell from *Phidget, S Type, model 3138*.



FINGER PAD		PAYLOAD		MEASURED FORCE MIN / MAX (N)	
TYPE	HARDNESS	TYPE	HARDNESS	2-Finger 85	2-Finger 140
Steel 4340	220 HV	Steel 4340	220 HV ³	25 - 220	15 - 120
Aluminium 60611	95 HV	Aluminium 6061	95 HV	25 - 220	15 - 120
Aluminium 60611	95 HV	Silicone (TIP-204) ²	60 A Durometer	25 - 220	15 - 120
Aluminium 60611	95 HV	Silicone rubber	40 A Durometer ⁴	25 - 155	15 - 100
Aluminium 60611	95 HV	Neoprene rubber	10 A Durometer	25 - 115	15 - 75
Aluminium 60611	95 HV	Polyurethane rubber	30 OO Durometer	25 - 115	15 - 75

¹ Available with V-Groove fingertip AGC-TIP-205-0085 / AGC-TIP-421-140.

² Available with flat silicone fingertip AGC-TIP-204-085 / AGC-TIP-420-140.

³ HV refers to Vickers hardness test.

⁴ Durometer refers to Shore durometer hardness, scale A or scale OO.



MEASURED GRIP FORCE ACCORDING TO SPEED & FORCE SETTING
FOR 220 HV HARDNESS MATERIAL (STEEL)

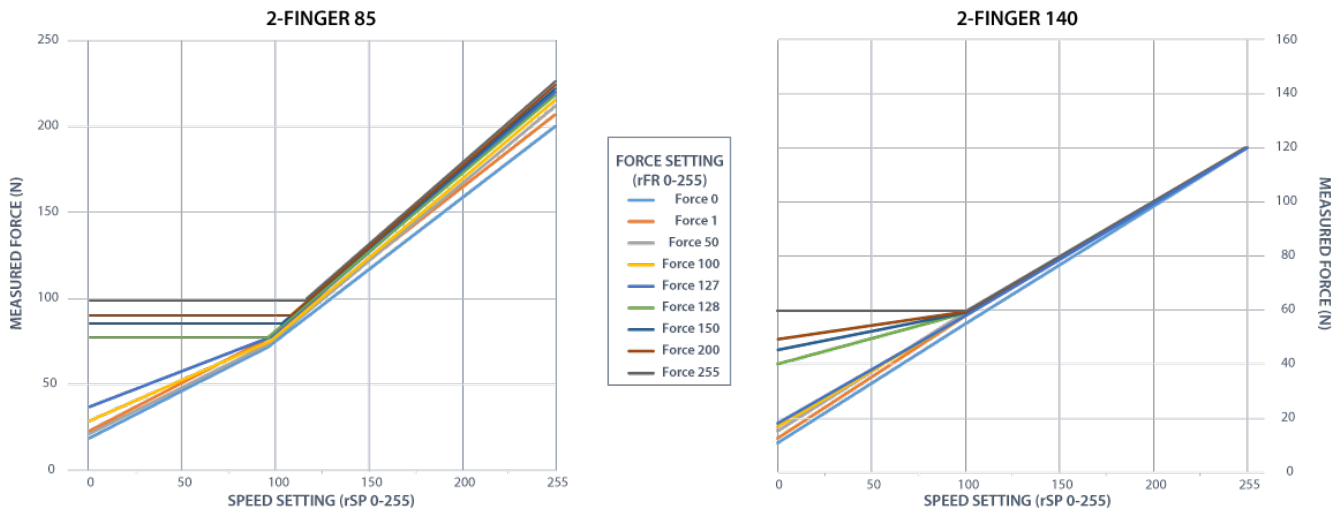

Fig. 4-2: grasp force on hardness 220 HV (4340 annealed carbon steel).

MEASURED GRIP FORCE ACCORDING TO SPEED & FORCE SETTING
FOR 95 HV HARDNESS MATERIAL (ALUMINIUM)

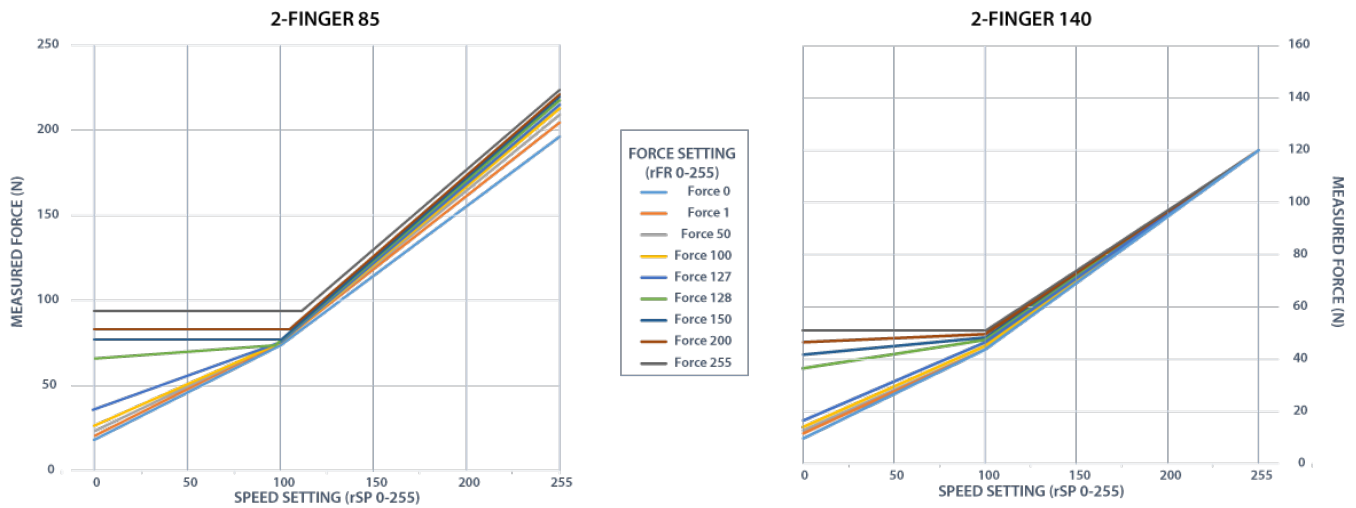

Fig. 4-3: grasp force on hardness 95 HV (6061-T6 aluminium).



MEASURED GRIP FORCE ACCORDING TO SPEED & FORCE SETTING
FOR 60A DUROMETER MATERIAL

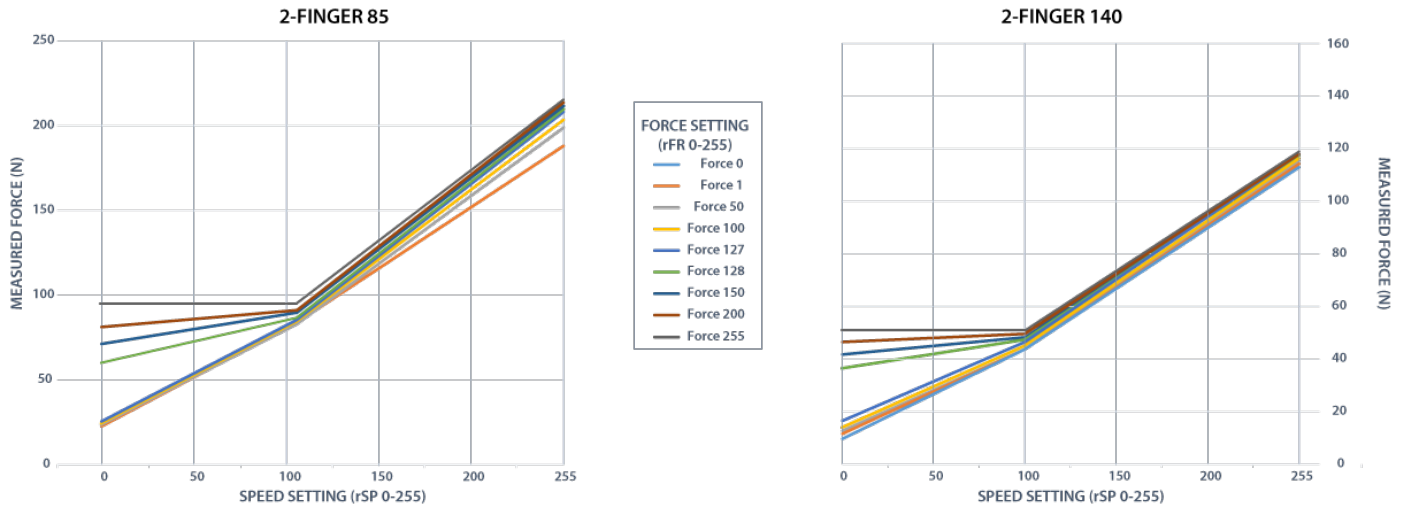

Fig. 4-4: grasp force on hardness 60A (silicone).

MEASURED GRIP FORCE ACCORDING TO SPEED & FORCE SETTING
FOR 40A DUROMETER MATERIAL

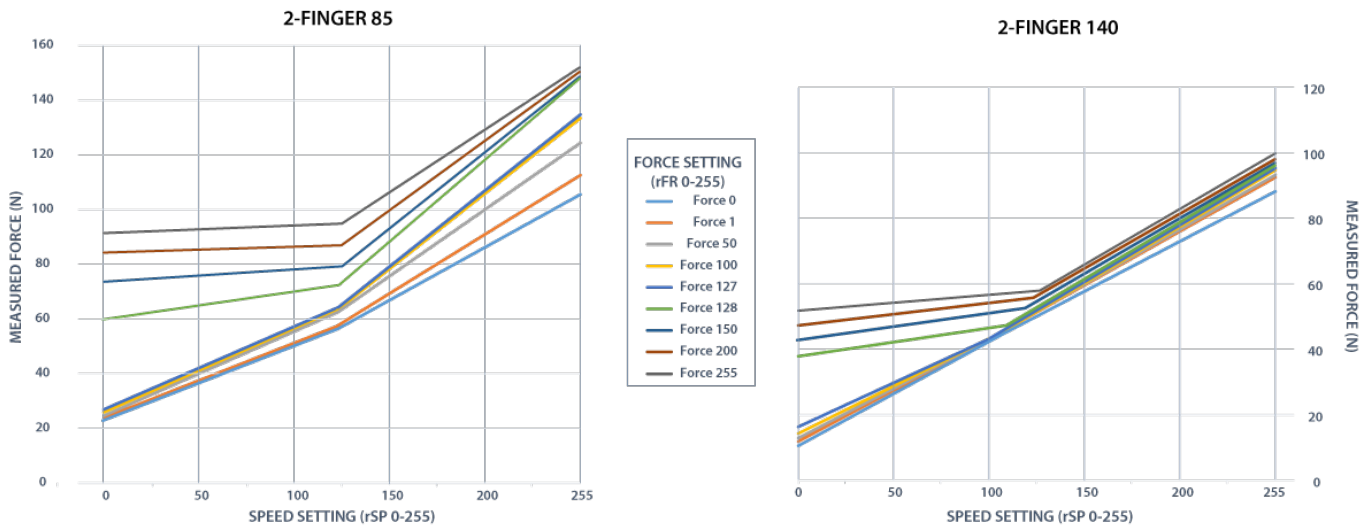

Fig. 4-5: grasp force on hardness 40 A (silicone).



MEASURED GRIP FORCE ACCORDING TO SPEED & FORCE SETTING FOR 10A DUROMETER MATERIAL

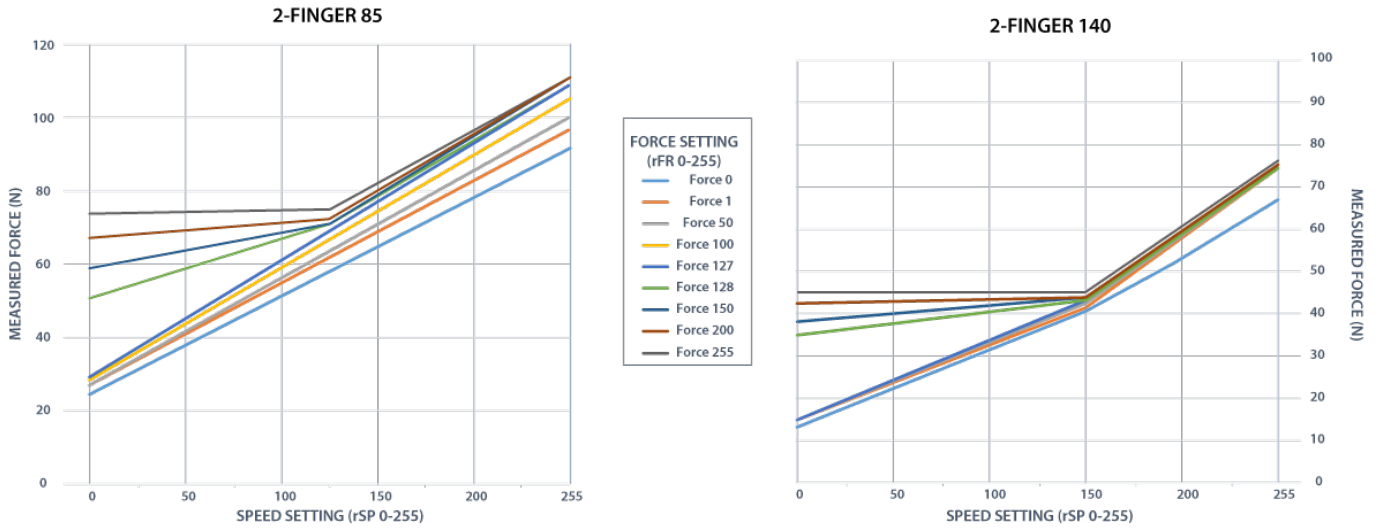

Fig. 4-6: grasp force on hardness 10 A (neoprene).

MEASURED GRIP FORCE ACCORDING TO SPEED & FORCE SETTING FOR 3000 DUROMETER MATERIAL

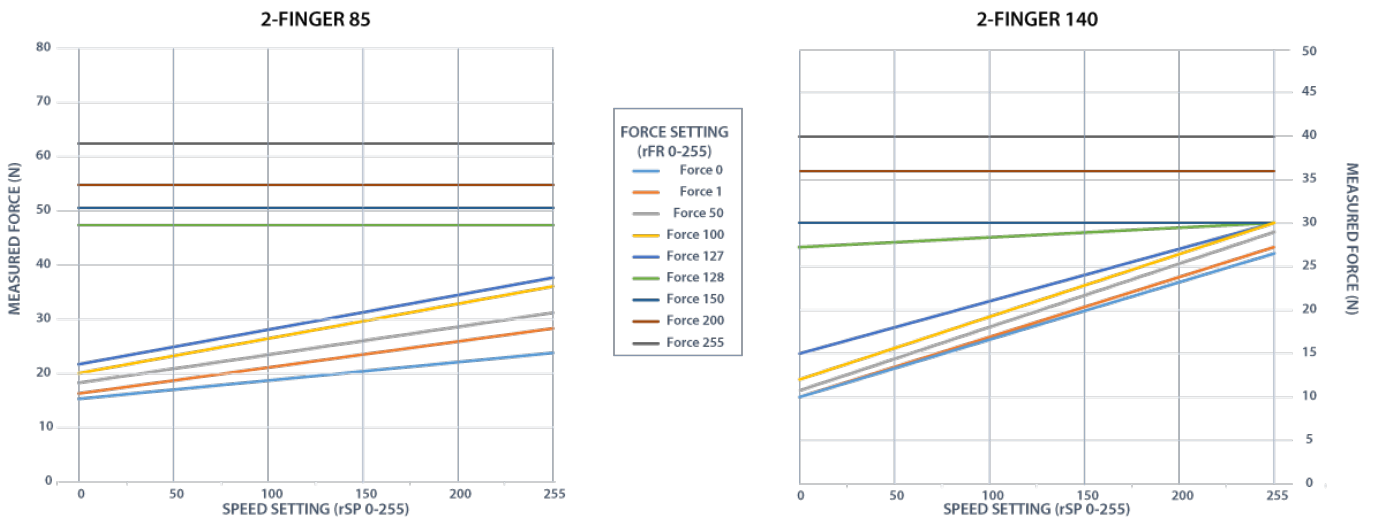

Fig. 4-7: grasp force on hardness 30 OO (polyurethane).



4.5.2. Re-Grasp

Re-grasp feature is a built-in feature meant to prevent object lost due to slipping or inaccurate initial grip. The Re-grasp feature will allow the Gripper to initiate movement when an object is slipping or dropped. When Re-grasping, the Gripper will attempt to close until it reaches the position (**rPR**) request.

- This feature is automatically set according to the force request **rFR**.

Info

Feature is off at force request **rFR** = 0, otherwise it is on.

- Re-grasp will keep the position setting:
 - Finger motion will stop when **rPR** position is reached, even if there is no object.
- Force and speed settings are not used, Re-grasp force and speed will automatically adjust to keep the object from being lost / dropped.

Info

While your initial settings for force and speed are not used for Re-grasp, they will never be exceeded to prevent damaging the object grasped.

Info

The rOBJ status is cleared when a motion is detected.



4.5.3. Object detection

When the Gripper grabs an object, **gOBJ** status will allow you to know if object retention was successful. This is a built-in feature for the 2-Finger Grippers meant to be used by the robot controller (or PLC) commanding the overall application. The Object detection feature will change the **gOBJ** status and can be used inside your robot program. As stated in the previous section:

gOBJ: Only valid if **gGTO** = 1.

- 0x00 - Fingers are in motion towards requested position. No object detected.
- 0x01 - Fingers have stopped due to a contact while opening before requested position. Object detected.
- 0x02 - Fingers have stopped due to a contact while closing before requested position. Object detected.
- 0x03 - Fingers are at requested position. No object detected or object has been lost / dropped.

Object detection exemple:

1. Set position, speed and force at maximum (full closing):
 - a. **rPR** == 0xFF, **rSP** == 0xFF, **rFR** == 0xFF,
2. Set "go to requested" will initiate movement :
 - a. **rGTO** == 0x01
3. Then object detection status will be "in motion"
 - a. **gOBJ** = 0x00
4. Until an object is picked, object detection status will then be "stopped due to contact while closing"
 - a. **gOBJ** = 0x02
5. The user can now assume it is holding the payload, and proceed to the next step.

Object lost exemple:

1. From previous exemple, after an object is picked, **gOBJ** = 0x02
2. If **gOBJ** = 0x03 after it was 0x02, user can assume the object as been lost.



4.6. Control Logic

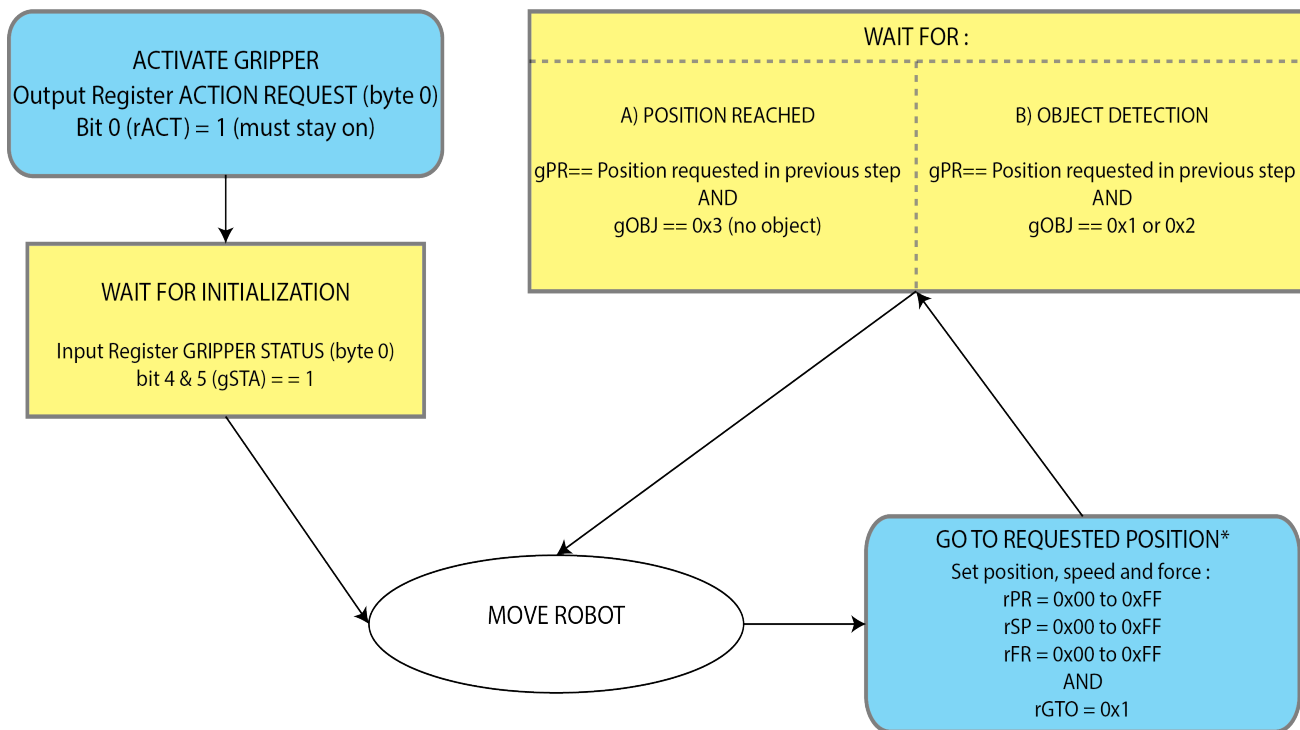

Legend:

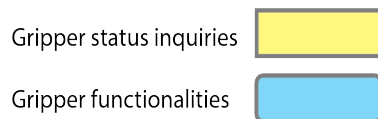

* Go to requested position is used to open / close the Gripper until object is detected or requested position is reached.

Fig. 4-8: Example of the 2-Finger control logic with associated registers.



4.7. Modbus RTU Communication

The Gripper can be controlled by Modbus RTU directly with RS485-RS232 using the ACC-ADT-RS232-RS485, or over USB using the ACC-ADT-USB-RS485. This section is intended to provide guidelines for setting up a Modbus scanner that will adequately communicate with the Gripper.

For a general introduction to Modbus RTU and for details regarding the CRC algorithm, the reader is invited to read the Modbus over serial line specification and implementation guide available at: http://www.modbus.org/docs/Modbus_over_serial_line_V1_02.pdf.

For debugging purposes, the reader is also invited to download one of many free Modbus scanners such as the *CAS Modbus Scanner* from Chipkin Automation Systems available at: <http://www.store.chipkin.com/products/tools/cas-modbus-scanner>.

Info

Modbus RTU is a communication protocol based on a Big Endian byte order. Therefore, the 16-bit register addresses are transmitted with the most significant byte first. However, the data port is in the case of Robotiq products based on the Little Endian byte order. As such, the data parts of Modbus RTU messages are sent with the less significant byte first.

Tip

Modbus RTU specification and details can be found at www.modbus.org.



4.7.1. Connection Setup

The following table describes the connection requirements for controlling the Gripper using the Modbus RTU protocol.

PROPRIETY	VALUE
Physical Interface	RS-485 ¹
Baud Rate ²	115,200 bps
Data Bits	8
Stop Bit ²	1
Parity ²	None
Supported Functions	Read Holding Register (FC03) Read Input Registers (FC04) Preset Multiple Register (FC16) Master read & write multiple registers (FC23)
Exception Responses	Not supported
Slave ID ²	0x0009 (9)
Robot Output / Gripper Input First Register	0x03E8 (1000)
Robot Input / Gripper Output First Register	0x07D0 (2000)

¹ Various converters are available in the Spare parts section.

² These parameters can be adjusted using the Robotiq User Interface.

Each register (word - 16 bits) of the Modbus RTU protocol is composed of **2** bytes (8 bits) from the Gripper. The first Gripper output Modbus register(0x07D0) is composed from the first **2** Robotiq Gripper bytes (byte 0 and byte 1).

Info

200 Hz is the usual speed when commanding / reading from the Robotiq Gripper. It is therefore recommended to send commands with a minimum delay of 5 ms between them.

Info

Maximum baud rate of **ACC-ADT-USB-RS485** is 115200 bps.

120 Ohms termination resistor is already present on the converter.



4.7.2. Read holding registers (FC03)

Function code 03 (FC03) is used for reading the status of the Gripper (robot input). Examples of such data are Gripper status, object status, finger position, etc.

Example of FC03 Read function:

This message asks for register 0x07D0 (2000) and register 0x07D1 (2001) which contains Gripper Status, Object Detection, Fault Status and Position Request Echo.

Request is: 09 03 07 D0 00 02 C5 CE

Bits	Description
09	SlaveID
03	Function Code 03 (Read Holding Registers)
07D0	Address of the first requested register
0002	Number of registers requested (2)
C5CE	Cyclic Redundancy Check (CRC)

Response is: 09 03 04 E0 00 00 00 44 33

Bits	Description
09	SlaveID
03	Function Code 03 (Read Holding Registers)
04	Number of data bytes to follow (2 registers x 2 bytes/register = 4 bytes)
E000	Content of register 07D0
0000	Content of register 07D1
4433	Cyclic Redundancy Check (CRC)



4.7.3. Read input registers (FC04)

Function code 04 (FC04) is used for requesting the status of the Gripper's analog input register. Examples of such data are Gripper status, object status, finger position, etc.

Example of FC04 read function:

This message asks for register 0x07D0 (2000) and register 0x07D1 (2001) which contains Gripper Status, Object Detection, Fault Status and Position Request Echo.

Request is: 09 04 07 D0 00 02 C5 CE

Bits	Description
09	SlaveID
04	Function Code 03 (Read Holding Registers)
07D0	Address of the first requested register
0002	Number of registers requested (2)
700E	Cyclic Redundancy Check (CRC)

Response is: 09 04 04 E0 00 00 00 44 33

Bits	Description
09	SlaveID
04	Function Code 04 (Read Holding Registers)
04	Number of data bytes to follow (2 registers x 2 bytes/register = 4 bytes)
E000	Content of register 07D0
0000	Content of register 07D1
4584	Cyclic Redundancy Check (CRC)



4.7.4. Preset multiple registers (FC16)

Function code 16 (FC16) is used to activate functionalities of the Gripper (robot output). Examples of such data are action request, speed, force, etc.

Example of setting multiple registers FC16:

This message requests to set position request, speed and force of the Gripper by setting register 0x03E9 (1002) and 0x03EA.

Request is: 09 10 03 E9 00 02 04 60 E6 3C C8 EC 7C

Bits	Description
09	SlaveID
10	Function Code 16 (Preset Multiple Registers)
03E9	Address of the first register
0002	Number of registers written to
04	Number of data bytes to follow (2 registers x 2 bytes/register = 4 bytes)
60E6	Value written to register 0x03E9
3CC8	Value written to register 0x03EA
EC7C	Cyclic Redundancy Check (CRC)

Response is: 09 10 03 E9 00 02 91 30

Bits	Description
09	SlaveID
10	Function Code 16 (Preset Multiple Registers)
03E9	Address of the first register
0002	Number of written registers
9130	Cyclic Redundancy Check (CRC)



4.7.5. Master read & write multiple registers FC23

Function code 23 (FC23) is used for reading the status of the Gripper (robot input) and activating functionalities of the Gripper (robot output) simultaneously. Examples of such data are Gripper status, object status, finger position, etc. Action requests are speed, force, etc.

Example of reading and writing multiple registers FC23:

This message reads registers 0x07D0 (2000) and 0x07D1 (2001), which contains Gripper Status, Object Detection, Fault Status and Position Request Echo. It also sets the position request, speed and force of the Gripper by writing to registers 0x03E9 (1001) and 0x03EA (1002).

Request is: 09 17 07 D0 00 02 03 E9 00 02 04 00 E6 3C C8 2D 0C

Bits	Description
09	SlaveID
17	Function Code 23 (read and write multiple registers)
07D0	Address of the first requested register, read
0002	Number of registers requested (2), read
03E9	Address of the first register written to
0002	Number of registers written to (3)
04	Number of data bytes to follow (2 registers X 2 bytes/registers = 4 bytes)
00E6	Value written to register 0x03E9
3CC8	Value written to register 0x03EA
2D0C	Cyclic Redundancy Check (CRC)

Response is: 09 17 04 01 00 09 E6 F6 C1

Bits	Description
09	SlaveID
17	Function Code 23 (read and write multiple registers)
04	Number of data bytes to follow (2 registers x 2 bytes/register = 4 bytes)
1000	Content of register 07D0



Bits	Description
09E6	Content of register 07D1
F6C1	Cyclic Redundancy Check (CRC)

Note that the content of the response might change depending on the Gripper's status.



4.7.6. Modbus RTU example

This section depicts the example given in the **Control Logic** section when programmed using the Modbus RTU protocol. The example is typical of a pick and place application. After activating the Gripper, the robot is moved to a pick-up location to grasp an object. It moves again to a second location to release the grasped object.

Step 1: Activation Request (clear and set rACT)

Request is (clear rAct): 09 10 03 E8 00 03 06 00 00 00 00 00 00 73 30

Bits	Description
09	SlaveID
10	Function Code 16 (Preset Multiple Registers)
03E8	Address of the first register
0003	Number of registers written to
06	Number of data bytes to follow (3 registers x 2 bytes/register = 6 bytes)
0000	Value to write to register 0x03E9 (ACTION REQUEST = 0x01 and GRIPPER OPTIONS = 0x00): rACT = 1 for "Activate Gripper"
0000	Value written to register 0x03EA
0000	Value written to register 0x03EB
7330	Cyclic Redundancy Check (CRC)

Response is: 09 10 03 E8 00 03 01 30

Bits	Description
09	SlaveID
10	Function Code 16 (Preset Multiple Registers)
03E8	Address of the first register
0003	Number of written registers
0130	Cyclic Redundancy Check (CRC)



Request is (set rAct): 09 10 03 E8 00 03 06 01 00 00 00 00 00 72 E1

Bits	Description
09	SlaveID
10	Function Code 16 (Preset Multiple Registers)
03E8	Address of the first register
0003	Number of registers written to
06	Number of data bytes to follow (3 registers x 2 bytes/register = 6 bytes)
0100	Value to write to register 0x03E9 (ACTION REQUEST = 0x01 and GRIPPER OPTIONS = 0x00): rACT = 1 for "Activate Gripper"
0000	Value written to register 0x03EA
0000	Value written to register 0x03EB
72E1	Cyclic Redundancy Check (CRC)

Response is: 09 10 03 E8 00 03 01 30

Bits	Description
09	SlaveID
10	Function Code 16 (Preset Multiple Registers)
03E8	Address of the first register
0003	Number of written registers
0130	Cyclic Redundancy Check (CRC)



Step 2: Read Gripper status until the activation is completed

Request is: 09 03 07 D0 00 01 85 CF

Bits	Description
09	SlaveID
03	Function Code 03 (Read Holding Registers)
07D0	Address of the first requested register
0001	Number of registers requested (1)
85CF	Cyclic Redundancy Check (CRC)

Response (if the activation IS NOT completed): 09 03 02 11 00 55 D5

Bits	Description
09	SlaveID
03	Function Code 03 (Read Holding Registers)
02	Number of data bytes to follow (1 register x 2 bytes/register = 2 bytes)
1100	Content of register 07D0 (GRIPPER STATUS = 0x11, RESERVED = 0x00): gACT = 1 for "Gripper Activation", gSTA = 1 for "Activation in progress"
55D 5	Cyclic Redundancy Check (CRC)

Response (if the activation IS completed): 09 03 02 31 00 4C 15

Bits	Description
09	SlaveID
03	Function Code 03 (Read Holding Registers)
02	Number of data bytes to follow (1 register x 2 bytes/register = 2 bytes)
3100	Content of register 07D0 (GRIPPER STATUS = 0x31, RESERVED = 0x00): gACT = 1 for "Gripper Activation", gSTA = 3 for "Activation is completed"
4C15	Cyclic Redundancy Check (CRC)



Step 3: Move the robot to the pick-up location

Step 4: Close the Gripper at full speed and full force

Request is: 09 10 03 E8 00 03 06 09 00 00 FF FF FF 42 29

Bits	Description
09	SlaveID
10	Function Code 16 (Preset Multiple Registers)
03E8	Address of the first register
0003	Number of registers written to
06	Number of data bytes to follow (3 registers x 2 bytes/register = 6 bytes)
0900	Value written to register 0x03E8 (ACTION REQUEST = 0x09 and GRIPPER OPTIONS = 0x00): rACT = 1 for "Activate Gripper", rGTO = 1 for "Go to Requested Position"
00FF	Value written to register 0x03E9 (GRIPPER OPTIONS 2 = 0x00 and POSITION REQUEST = 0xFF): rPR = 255/255 for full closing of the Gripper
FFFF	Value written to register 0x03EA (SPEED = 0xFF and FORCE = 0xFF): full speed and full force
4229	Cyclic Redundancy Check (CRC)

Response is: 09 10 03 E8 00 03 01 30

Bits	Description
09	SlaveID
10	Function Code 16 (Preset Multiple Registers)
03E8	Address of the first register
0003	Number of written registers
0130	Cyclic Redundancy Check (CRC)



Step 5: Read Gripper status until the grasp is completed

Request is: 09 03 07 D0 00 03 04 0E

Bits	Description
09	SlaveID
03	Function Code 03 (Read Holding Registers)
07D0	Address of the first requested register
0003	Number of registers requested (3)
040E	Cyclic Redundancy Check (CRC)

Example of response if the grasp is **not completed**: 09 03 06 39 00 00 FF 0E 0A F7 8B

Bits	Description
09	SlaveID
03	Function Code 03 (Read Holding Registers)
06	Number of data bytes to follow (3 registers x 2 bytes/register = 6 bytes)
3900	Content of register 07D0 (GRIPPER STATUS = 0x39, RESERVED = 0x00): gACT = 1 for "Gripper Activation", gGTO = 1 for "Go to Position Request" and gOBJ = 0 for "Fingers are in motion"
00FF	Content of register 07D1 (FAULT STATUS = 0x00, POSITION REQUEST ECHO = 0xFF): the position request echo tells that the command was well received and that the GRIPPER STATUS is valid.
0E0A	Content of register 07D2 (POSITION = 0x0E, FINGER CURRENT = 0x0A): the position is 14/255 and the motor current is 100mA (these values will change during motion)
F78B	Cyclic Redundancy Check (CRC)



Example of response if the grasp is **completed**: 09 03 06 B9 00 00 FF BD 00 1D 7C

Bits	Description
09	SlaveID
03	Function Code 03 (Read Holding Registers)
06	Number of data bytes to follow (3 registers x 2 bytes/register = 6 bytes)
B900	Content of register 07D0 (GRIPPER STATUS = 0xB9, RESERVED = 0x00): gACT = 1 for "Gripper Activation", gGTO = 1 for "Go to Position Request" and gOBJ = 2 for "Fingers have stopped due to a contact while closing"
00FF	Content of register 07D1 (FAULT STATUS = 0x00, POSITION REQUEST ECHO = 0xFF): the position request echo tells that the command was well received and that the GRIPPER STATUS is valid.
BD00	Content of register 07D2 (POSITION = 0xBD, FINGER CURRENT = 0x00): the position is 189/255 (can be used to validate the size of the seized object)
1D7C	Cyclic Redundancy Check (CRC)



Step 6: Move the robot to the release location

Step 7: Open the Gripper at full speed and full force

Request is: 09 10 03 E8 00 03 06 09 00 00 00 FF FF 72 19

Bits	Description
09	SlaveID
10	Function Code 16 (Preset Multiple Registers)
03E8	Address of the first register
0003	Number of registers written to
06	Number of data bytes to follow (3 registers x 2 bytes/register = 6 bytes)
0900	Value written to register 0x03E8 (ACTION REQUEST = 0x09 and GRIPPER OPTIONS = 0x00): rACT = 1 for "Activate Gripper", rGTO = 1 for "Go to Requested Position"
0000	Value written to register 0x03E9 (GRIPPER OPTIONS 2 = 0x00 and POSITION REQUEST = 0x00): rPR = 0/255 for full opening of the Gripper (partial opening would also be possible)
FFFF	Value written to register 0x03EA (SPEED = 0xFF and FORCE = 0xFF): full speed and full force
7219	Cyclic Redundancy Check (CRC)

Response is: 09 10 03 E8 00 03 01 30

Bits	Description
09	SlaveID
10	Function Code 16 (Preset Multiple Registers)
03E8	Address of the first register
0003	Number of written registers
0130	Cyclic Redundancy Check (CRC)



Step 8: Read Gripper status until the opening is completed

Request is: 09 03 07 D0 00 03 04 0E

Bits	Description
09	SlaveID
03	Function Code 03 (Read Holding Registers)
07D0	Address of the first requested register
0003	Number of registers requested (3)
040E	Cyclic Redundancy Check (CRC)

Example of response if the opening is **not completed**: 09 03 06 39 00 00 00 BB 10 30 E0

Bits	Description
09	SlaveID
03	Function Code 03 (Read Holding Registers)
06	Number of data bytes to follow (3 registers x 2 bytes/register = 6 bytes)
3900	Content of register 07D0 (GRIPPER STATUS = 0x39, RESERVED = 0x00): gACT = 1 for "Gripper Activation", gGTO = 1 for "Go to Position Request" and gOBJ = 0 for "Fingers are in motion"
0000	Content of register 07D1 (FAULT STATUS = 0x00, POSITION REQUEST ECHO = 0x00): the position request echo tells that the command was well received and that the GRIPPER STATUS is valid.
BB10	Content of register 07D2 (POSITION = 0xBB, FINGER CURRENT = 0x10): the position is 187/255 and the motor current is 160mA (these values will change during motion)
30E0	Cyclic Redundancy Check (CRC)



Example of response if the opening is **completed**: 09 03 06 F9 00 00 00 0D 00 56 4C

Bits	Description
09	SlaveID
03	Function Code 03 (Read Holding Registers)
06	Number of data bytes to follow (3 registers x 2 bytes/register = 6 bytes)
F900	Content of register 07D0 (GRIPPER STATUS = 0xF9, RESERVED = 0x00): gACT = 1 for "Gripper Activation", gGTO = 1 for "Go to Position Request" and gOBJ = 3 for "Fingers are at requested position"
0000	Content of register 07D1 (FAULT STATUS = 0x00, POSITION REQUEST ECHO = 0x00): the position request echo tells that the command was well received and that the GRIPPER STATUS is valid.
0D00	Content of register 07D2 (POSITION = 0x0D, FINGER CURRENT = 0x00): the position is 13/255 (the fingers have reached their software limit)
564C	Cyclic Redundancy Check (CRC)

Step 9: Loop back to step 3 if other objects have to be grasped.



4.8. Control over OMRON TM

4.8.1. TM Robots Compatibility with Robotiq Grippers

Hardware Version	TM Flow Version	TM Gripper Component	Robotiq RS232 Converter
HW1, HW2, HW3	1.68 and later	2F85_V004_XXX	Compatible

4.8.2. Getting Started

- 1 Power ON the robot
- 2 Tap the triple bar icon in the upper left corner of the screen

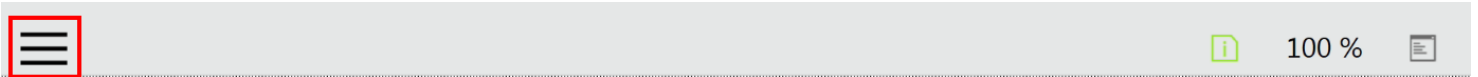

TM5-900

TM001145

Controlled by

3 Click on the **Login** icon in the navigation pane on the left

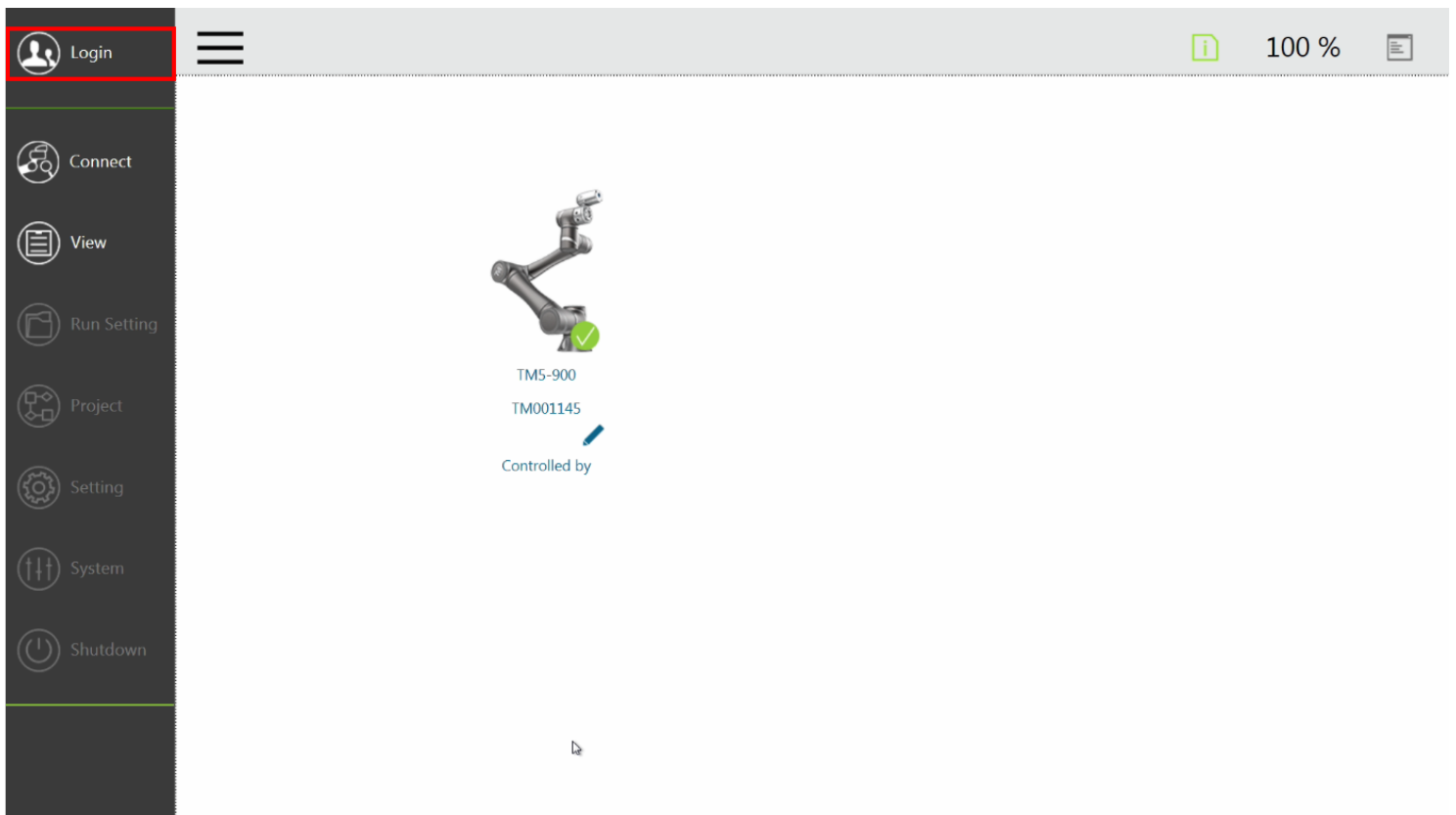

4 Enter your credentials and click on **OK**.

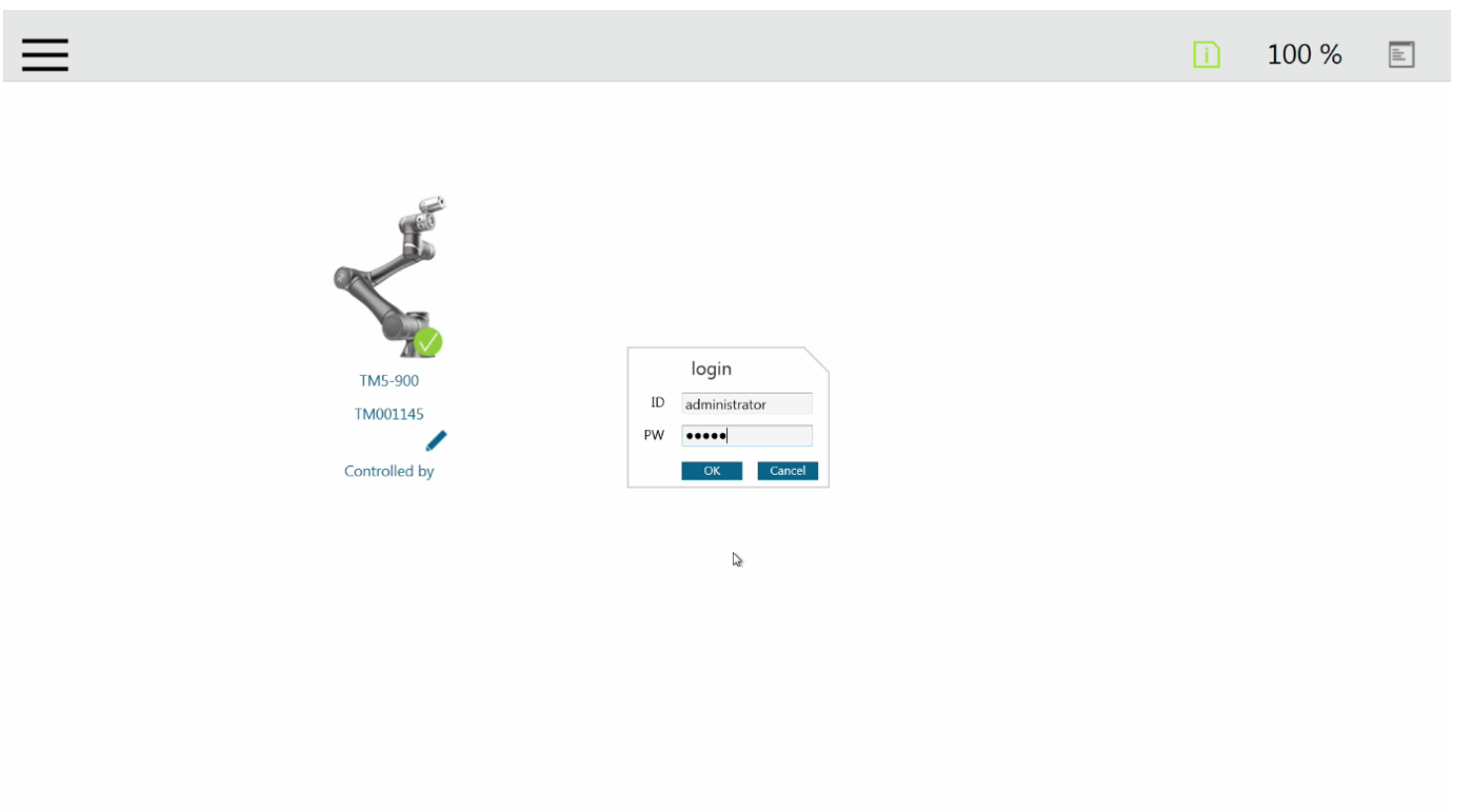

5 Click on Get Control

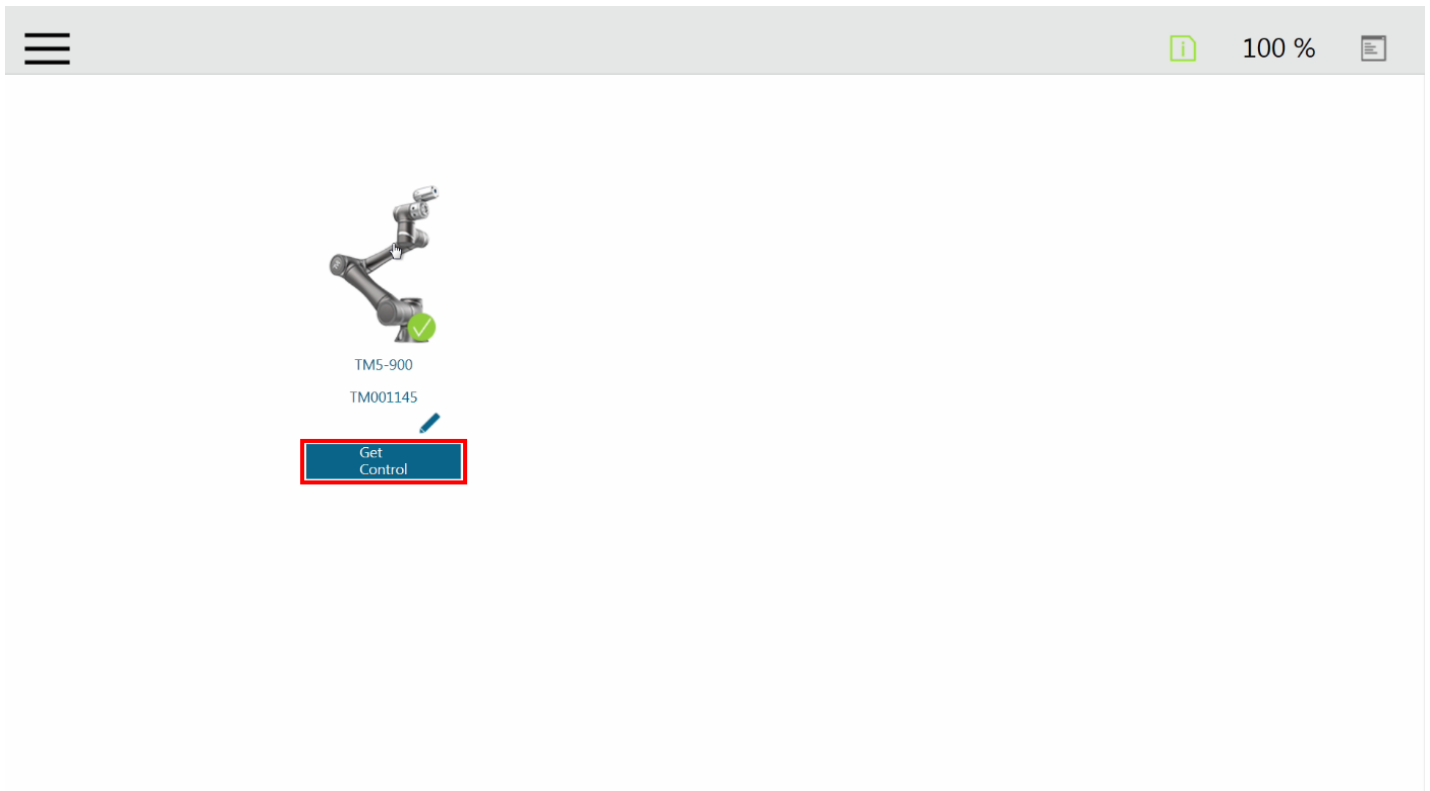

6 Click on the triple bar icon in the upper left corner of the screen and select Project

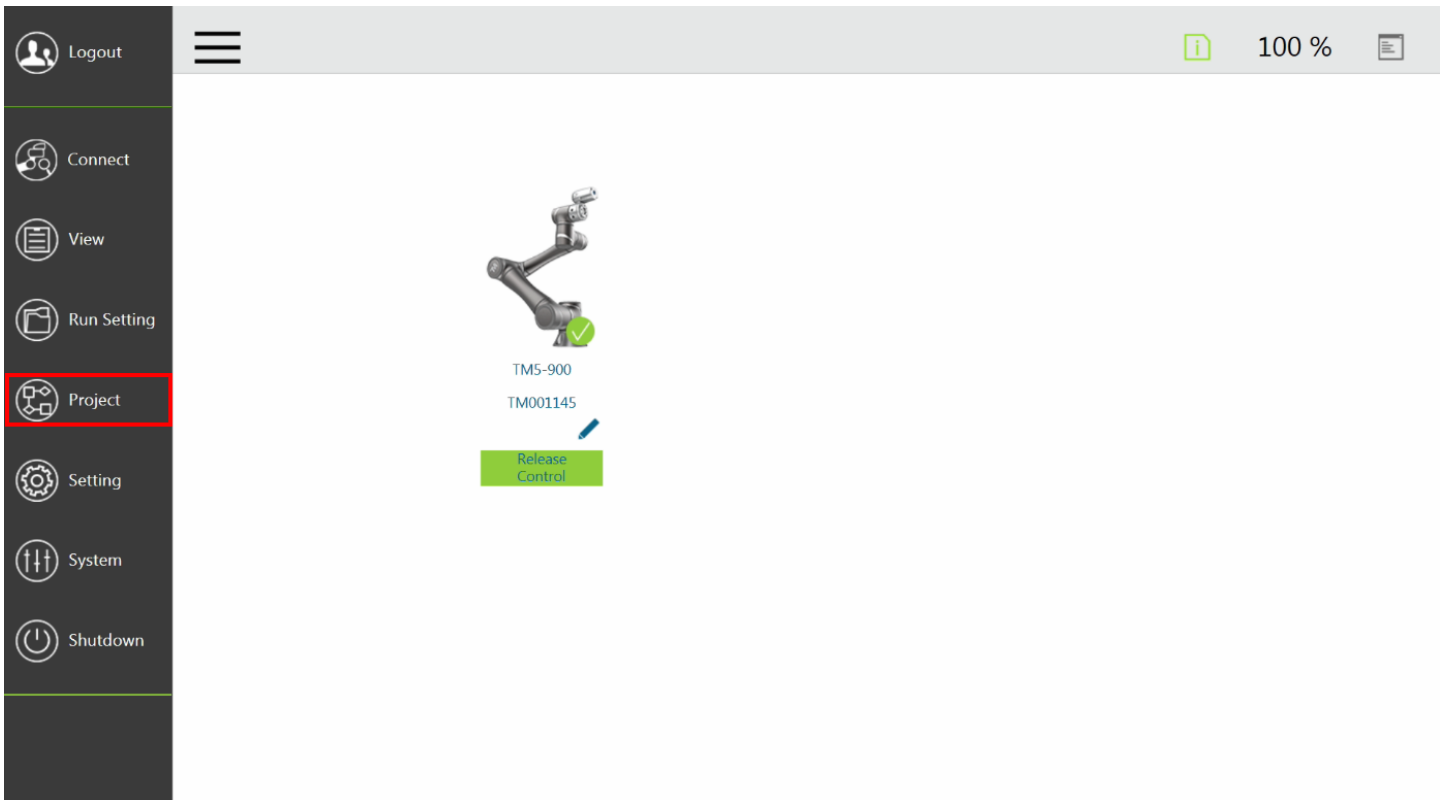

7 Click on the **New Project** icon in the upper left corner of the screen

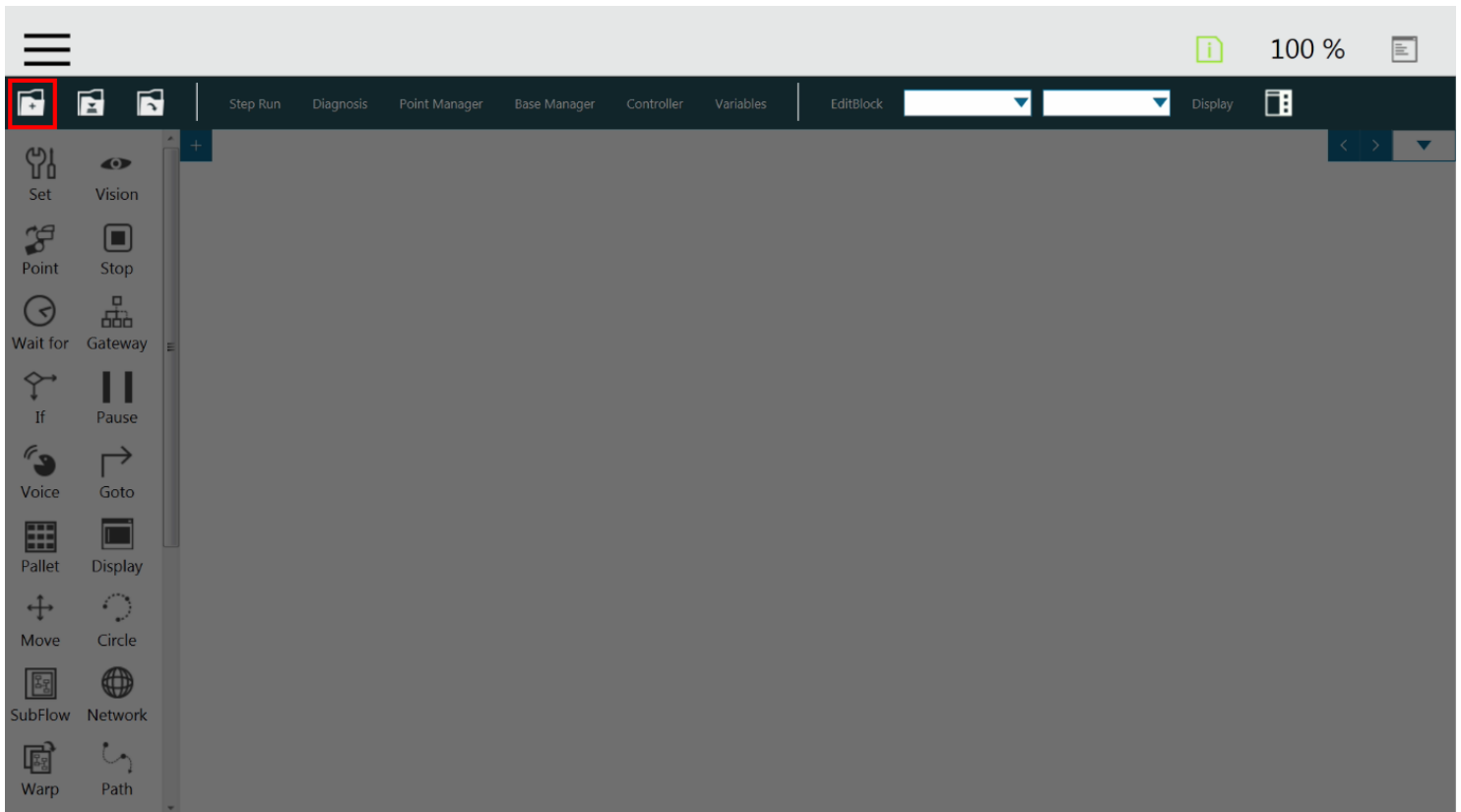

8 Enter a name for your program and click on the **OK** button.

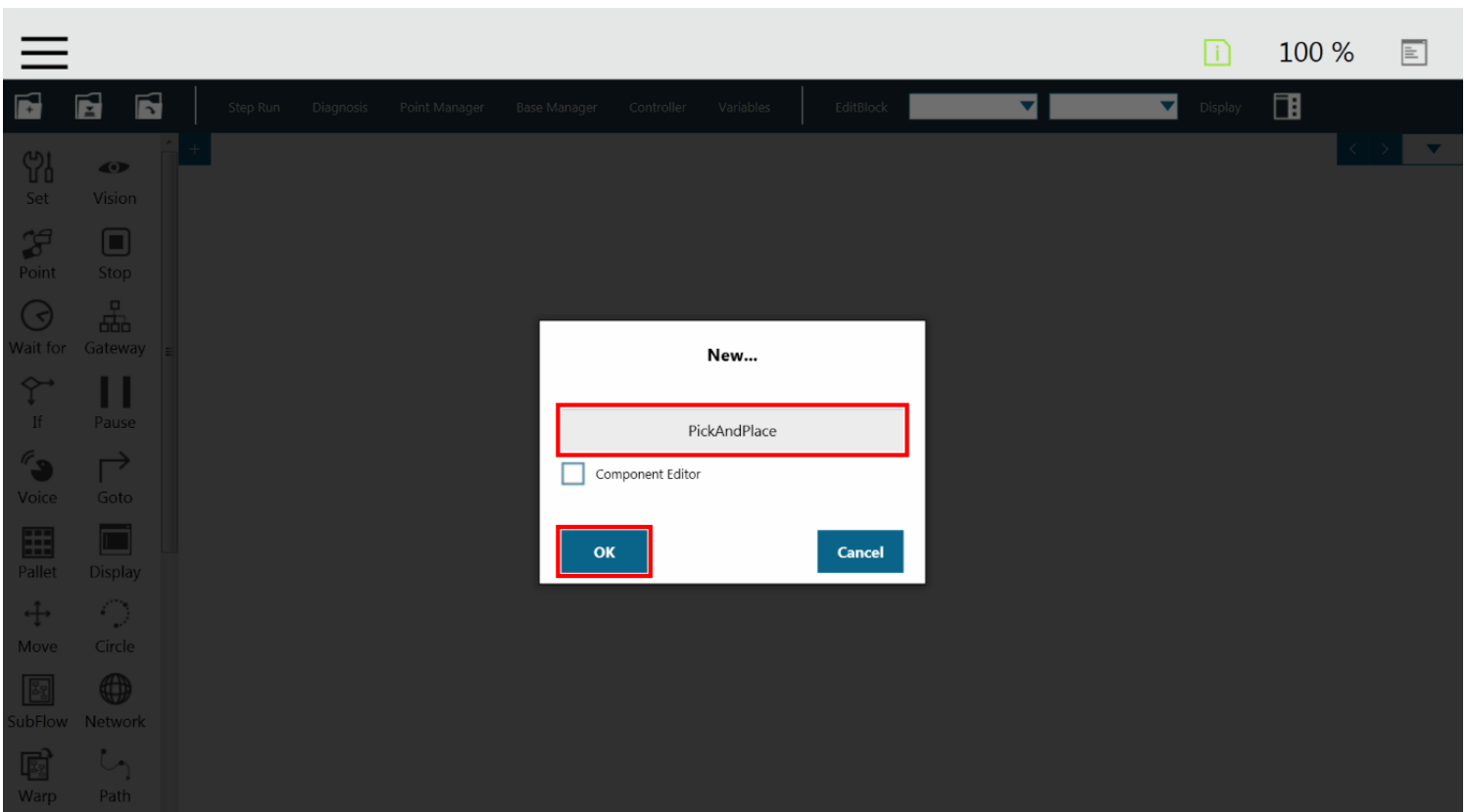

4.8.3. TM Gripper Components

Here is the list of the current Robotiq Gripper TM Components to install on TM Robots:

- GRIPPER_ROBOTIQ_2FIN85_V004_SET.Component = SET the Gripper (Speed, Force, Position)
- GRIPPER_ROBOTIQ_2FIN85_V004_GRIP.Component = CLOSE the Gripper (Action)
- GRIPPER_ROBOTIQ_2FIN85_V004_RELEASE.Component = OPEN the Gripper (Action)
- GRIPPER_ROBOTIQ_2FIN85_V004_CHANGEGRIPPER.Component = CHANGE the address of the Gripper/dual Gripper

Installation

- 1 Download the TM Plug & Play Software Package compression files on the [official website](#)
- 2 Unzip the file at the root of a blank USB storage device
- 3 Rename the USB storage device "TMROBOT"
- 4 Insert the USB storage device in the robot controller
- 5 In TM Flow (robot software), tap the triple bar icon and select **System Setting**

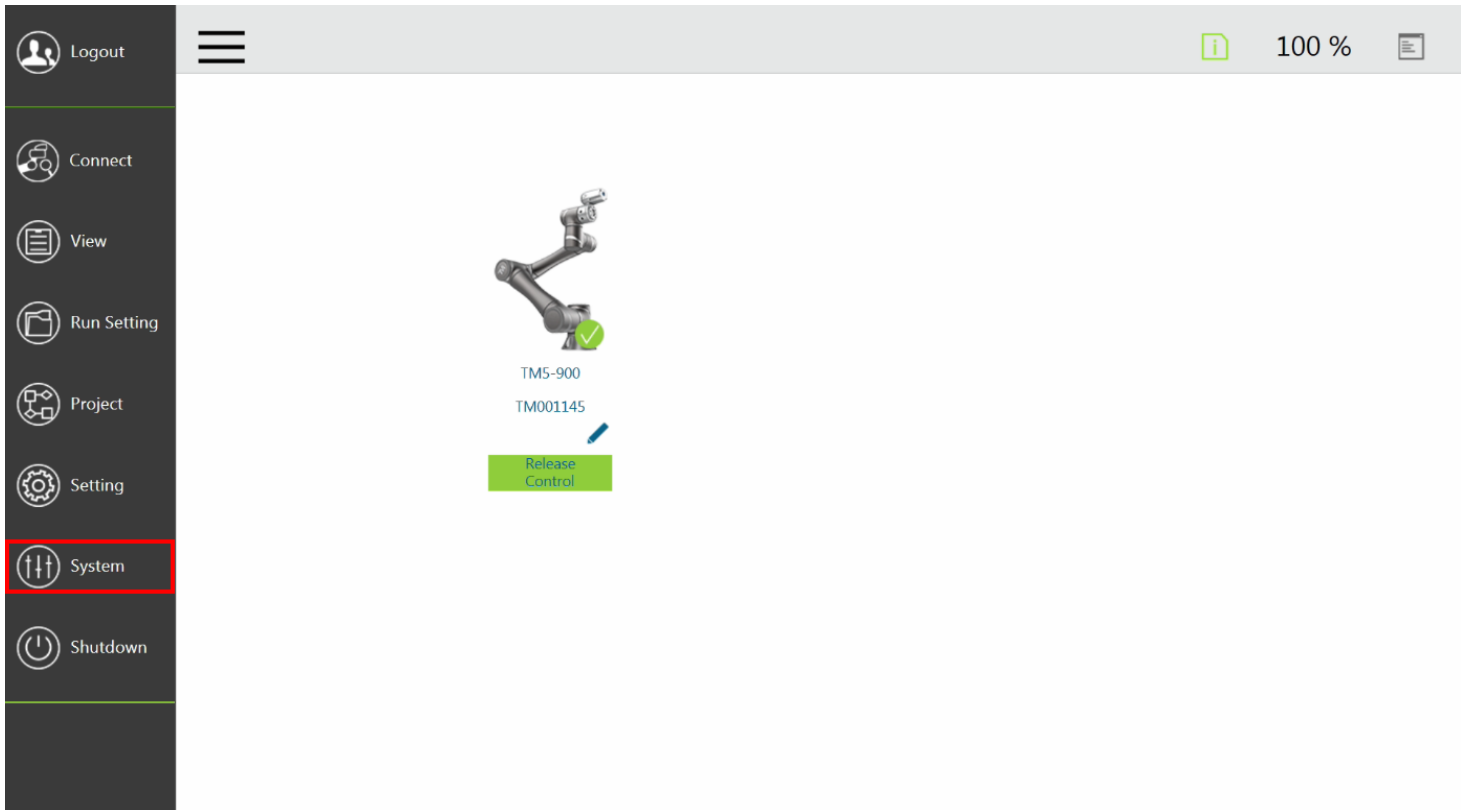

6 Select Import/Export

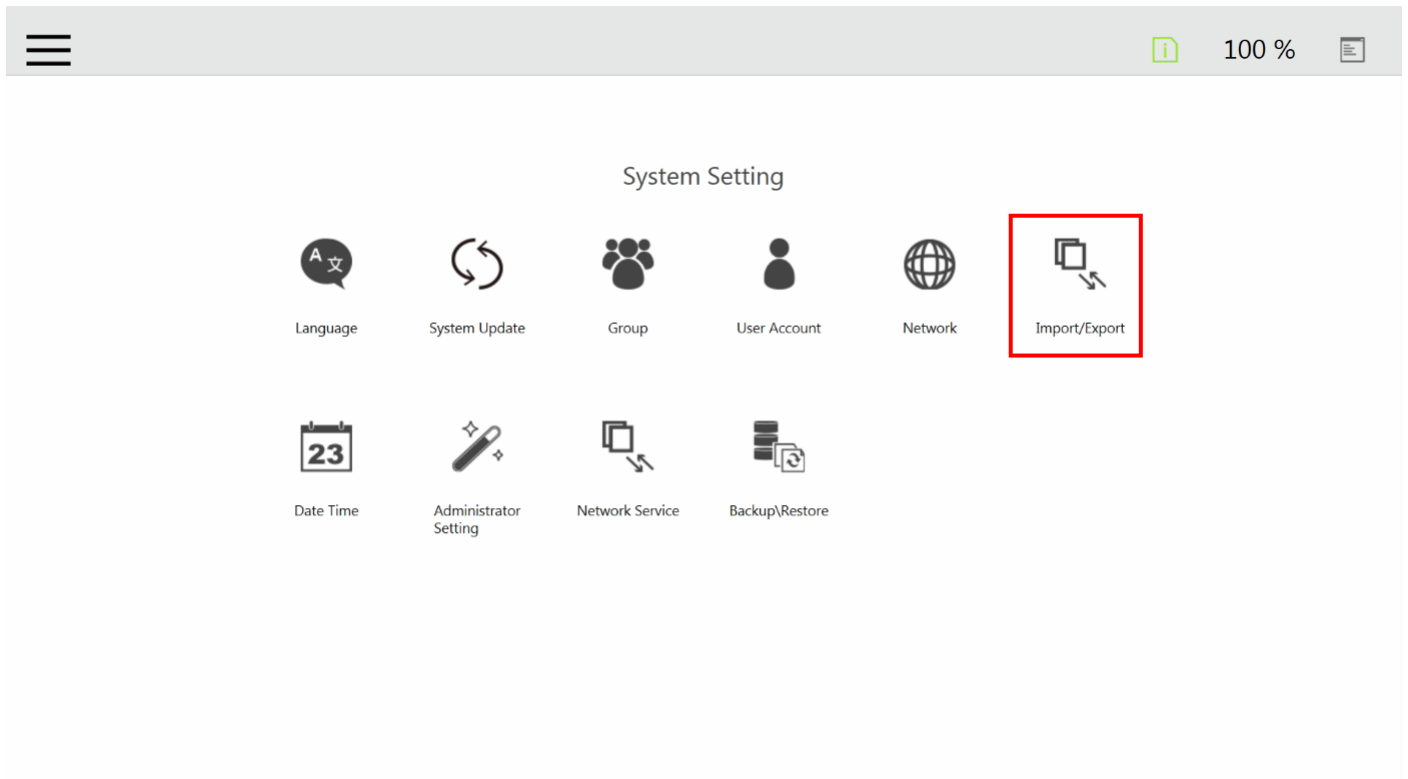

7 Click the Import button

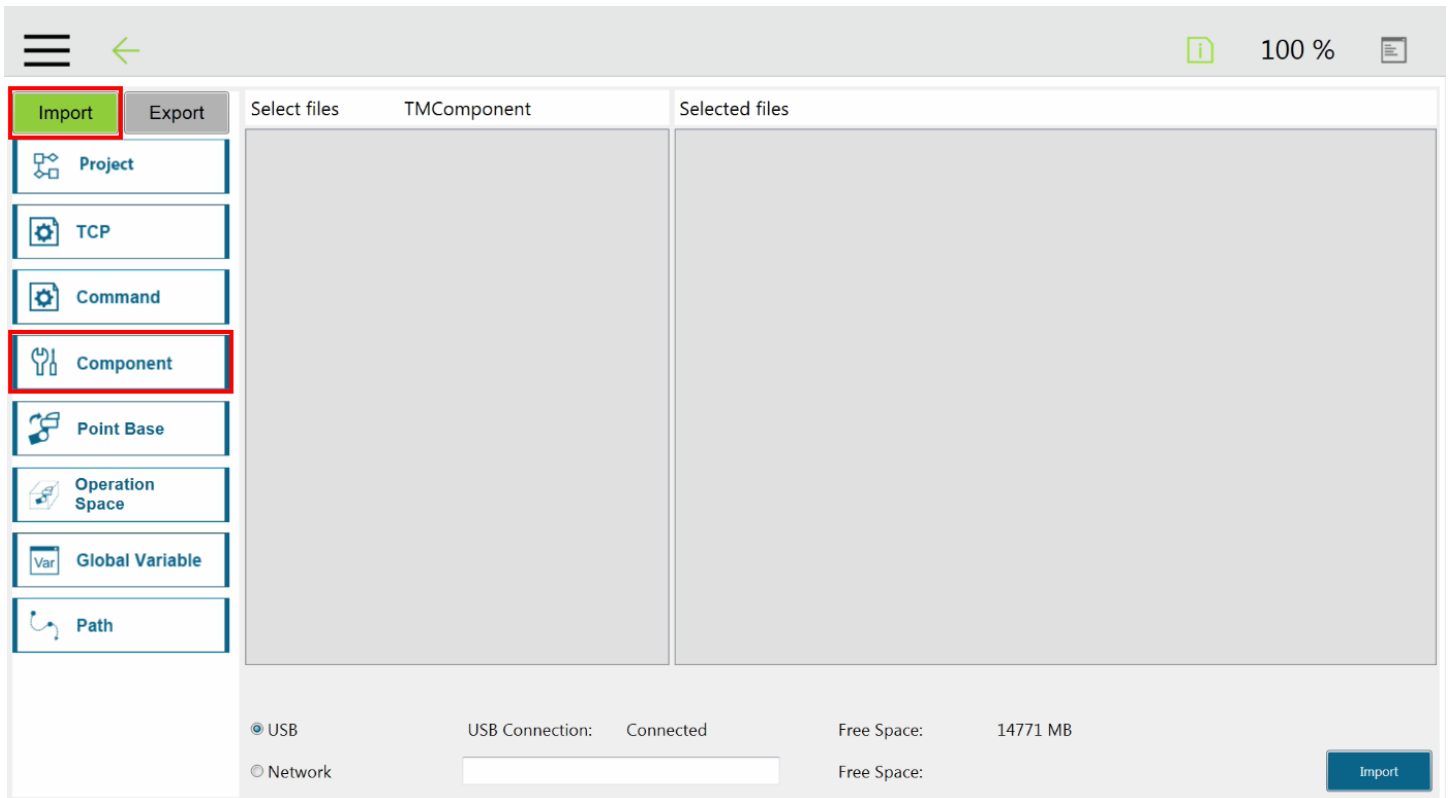

8 Click on **TMComponent** in the Robot List window and click on **OK**

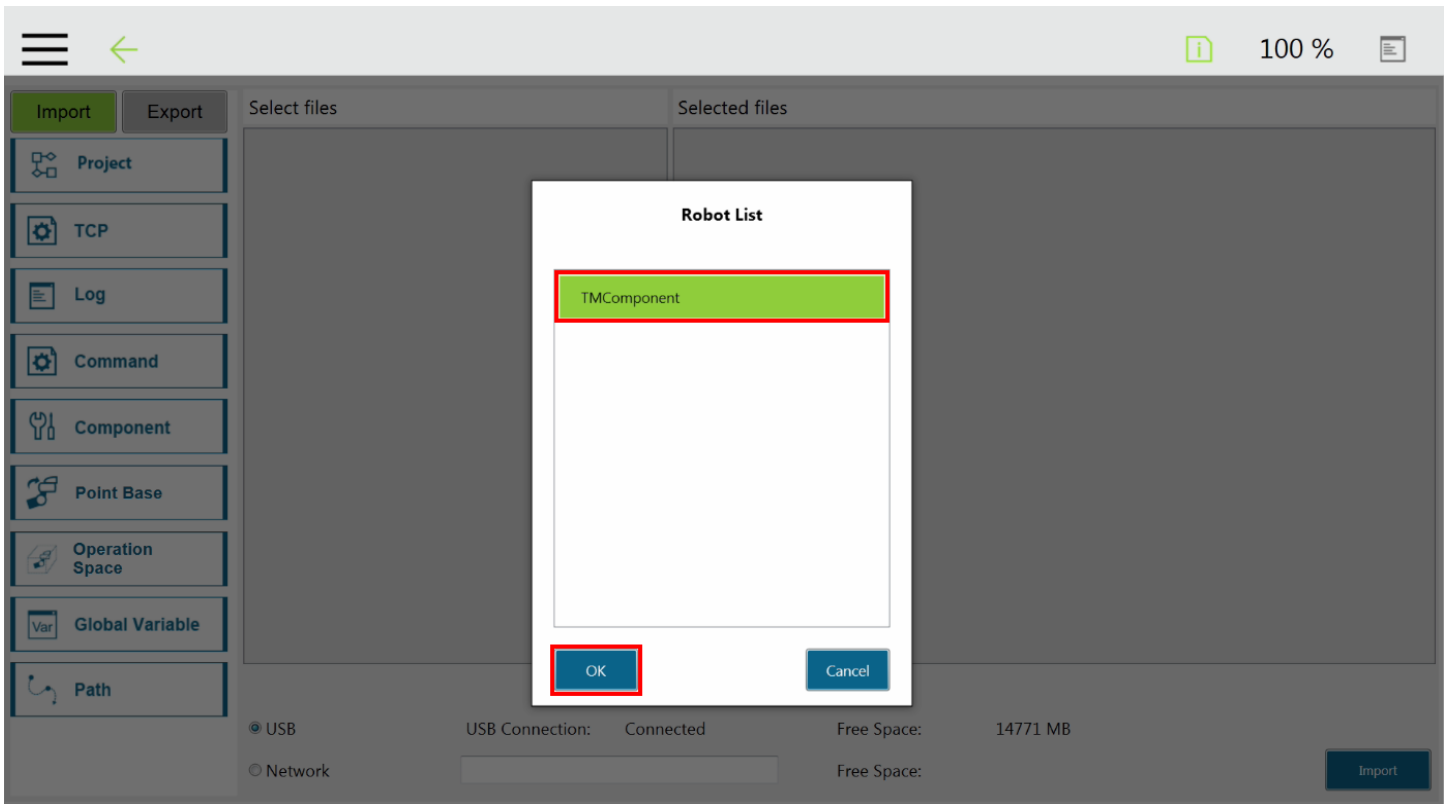

9 Click on the **Component** button of the **Import** navigation pane

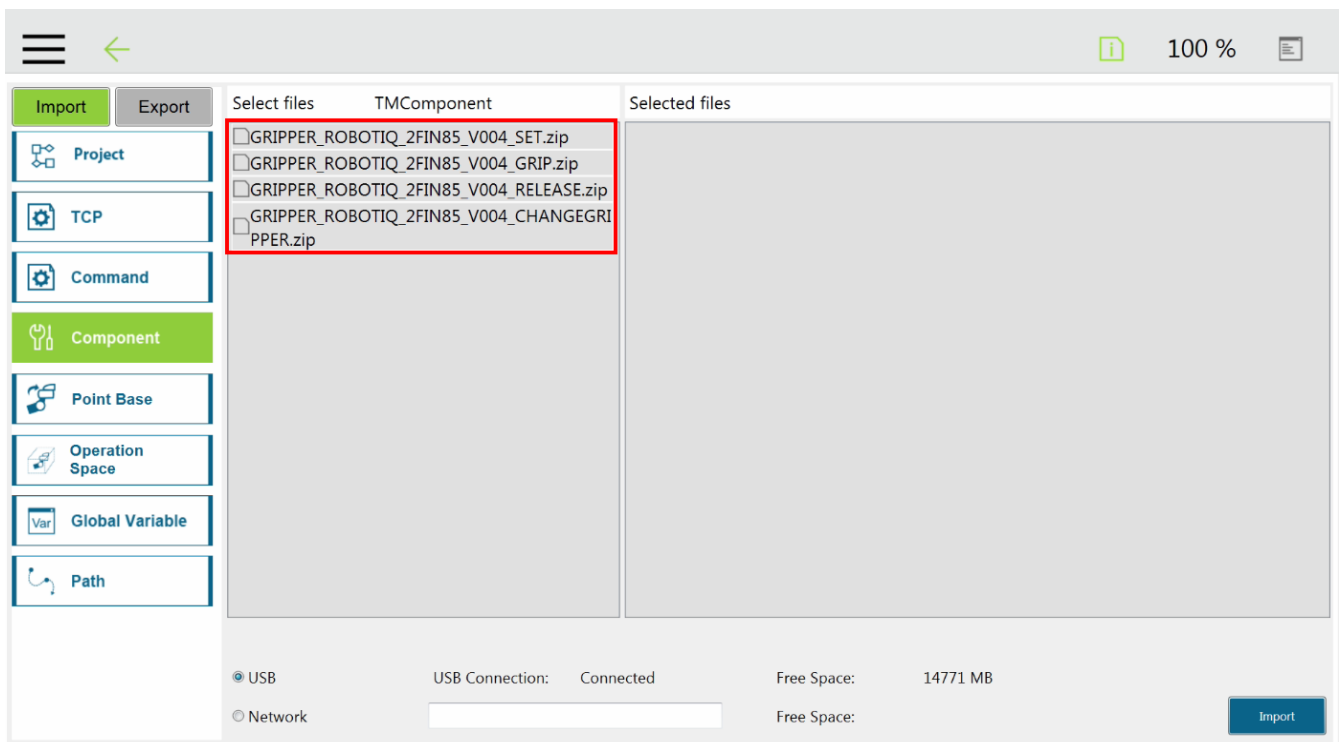

10 Select the Components you want to import and click on the **Import** button

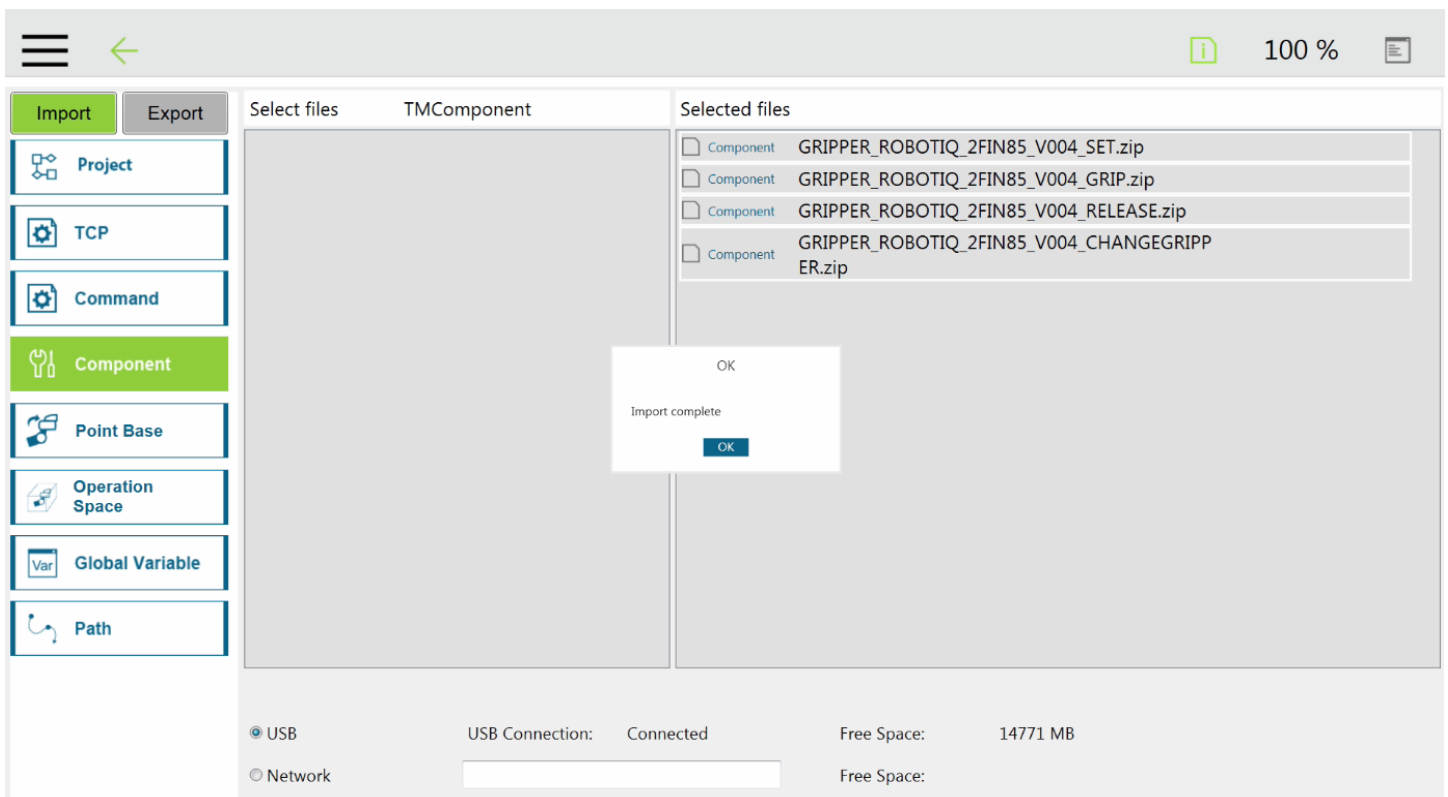
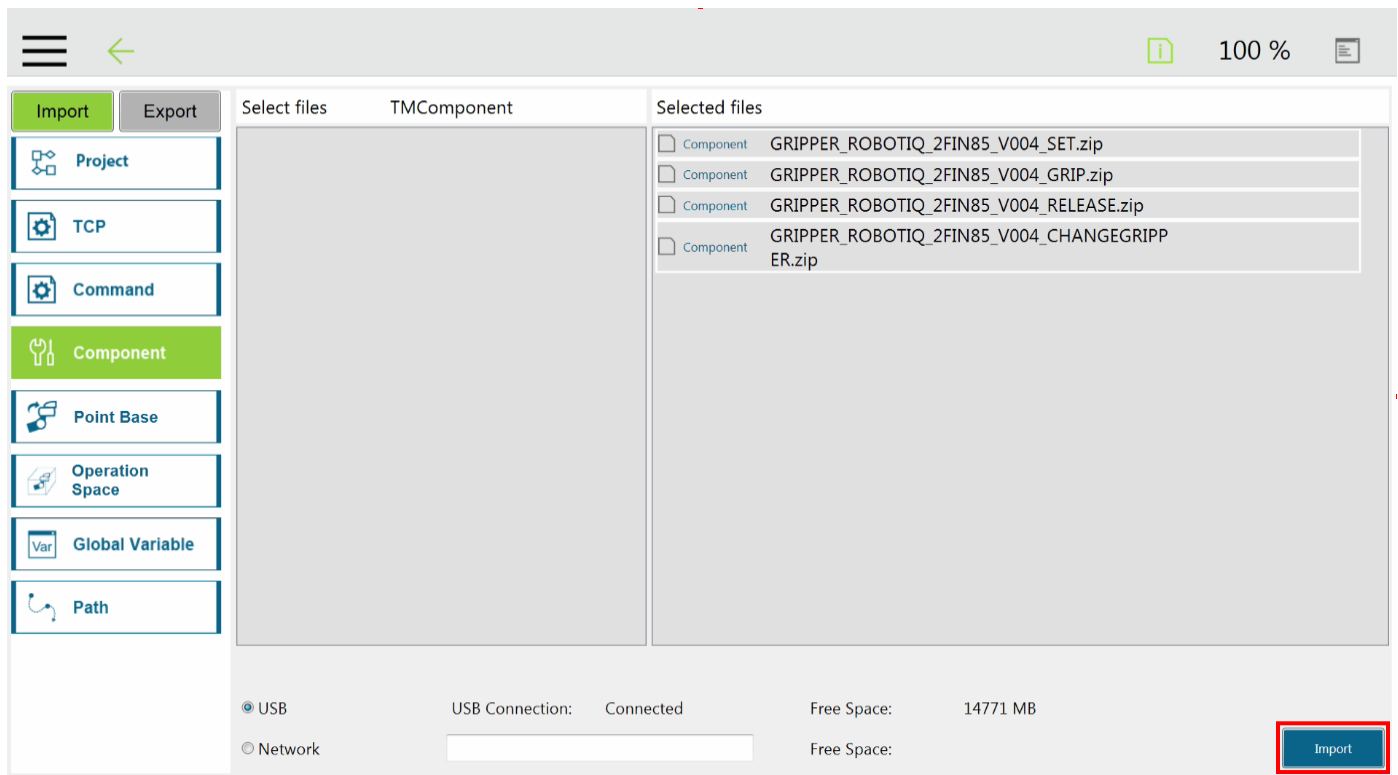

11 Tap the **triple bar icon** and select **Setting** to display the **Robot Setting** window

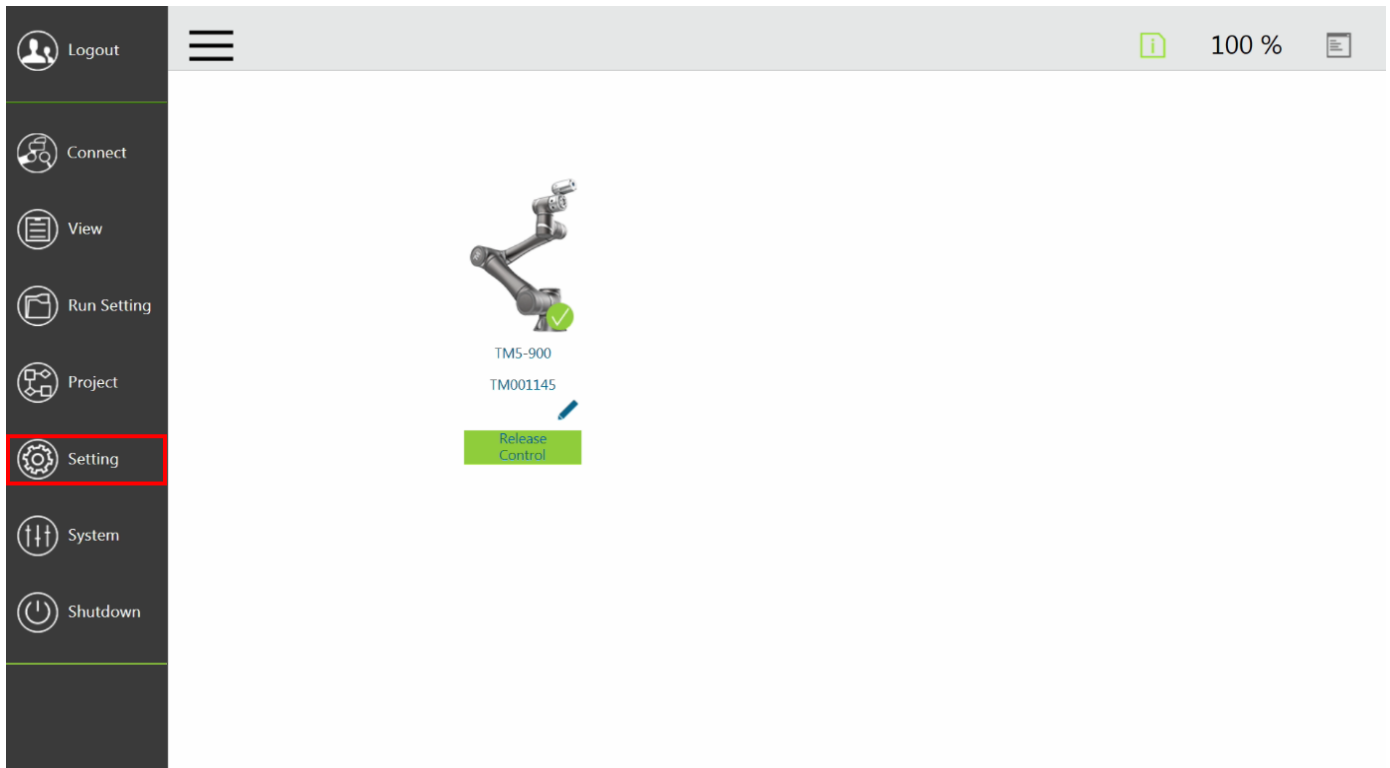

12 Click on the **Component** icon

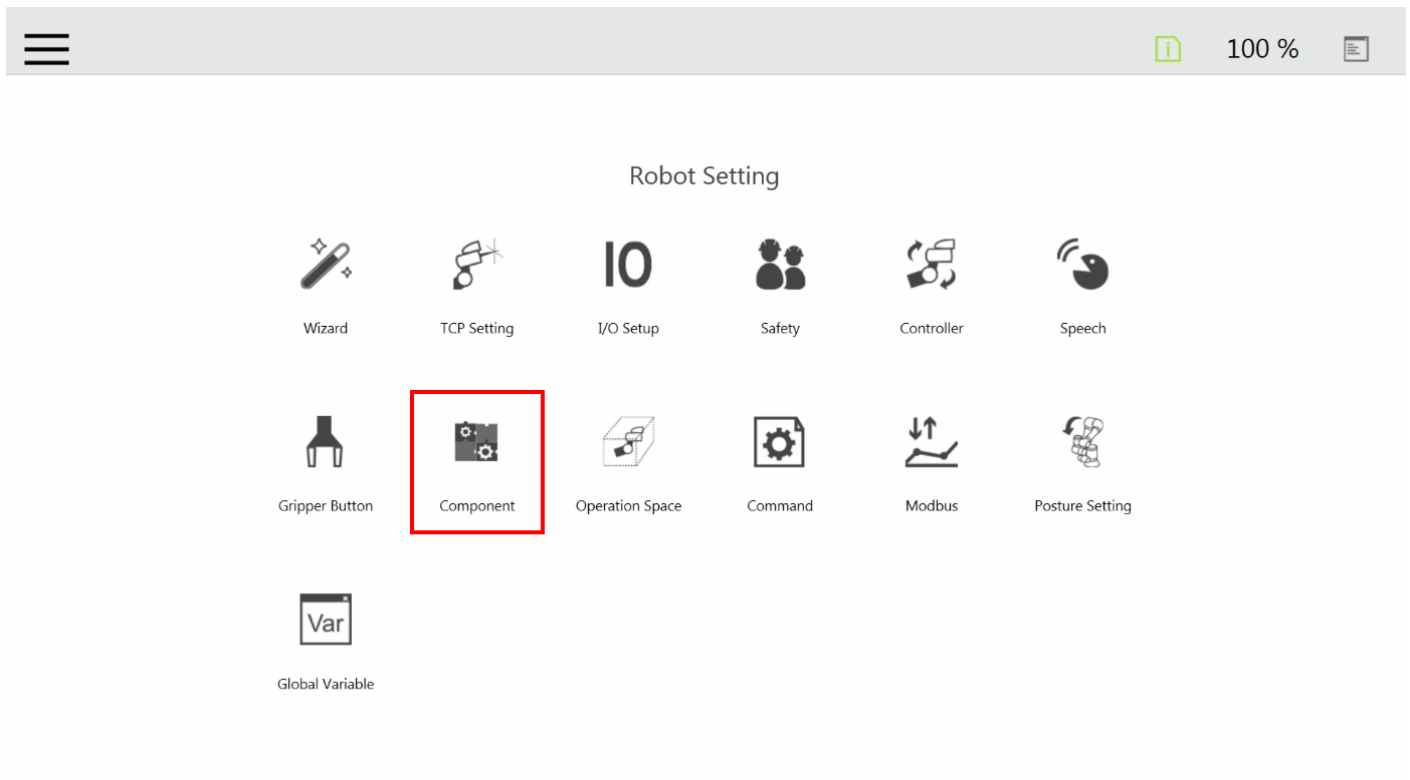

13 Enable required **Components** in the Components list by ticking the radio button beside each of them

☰ <
i 10 % ☰

Component List

Enable	Component Name	
<input type="radio"/>	GRIPPER_ROBOTIQ_2FIN85_V004_CHANGEGRIPPER.Component	✘
<input type="radio"/>	GRIPPER_ROBOTIQ_2FIN85_V004_GRIP.Component	✘
<input type="radio"/>	GRIPPER_ROBOTIQ_2FIN85_V004_RELEASE.Component	✘
<input type="radio"/>	GRIPPER_ROBOTIQ_2FIN85_V004_SET.Component	✘

Save

14 A Component that is enabled displays a green radio button; once the Components are enabled, click on the **Save** button

☰ <
i 100 % ☰

Component List

Enable	Component Name	
●	GRIPPER_ROBOTIQ_2FIN85_V004_CHANGEGRIPPER.Component	✘
●	GRIPPER_ROBOTIQ_2FIN85_V004_GRIP.Component	✘
●	GRIPPER_ROBOTIQ_2FIN85_V004_RELEASE.Component	✘
●	GRIPPER_ROBOTIQ_2FIN85_V004_SET.Component	✘

Save



15 Create a new project or open an existing project, and locate the Gripper components in the navigation pane

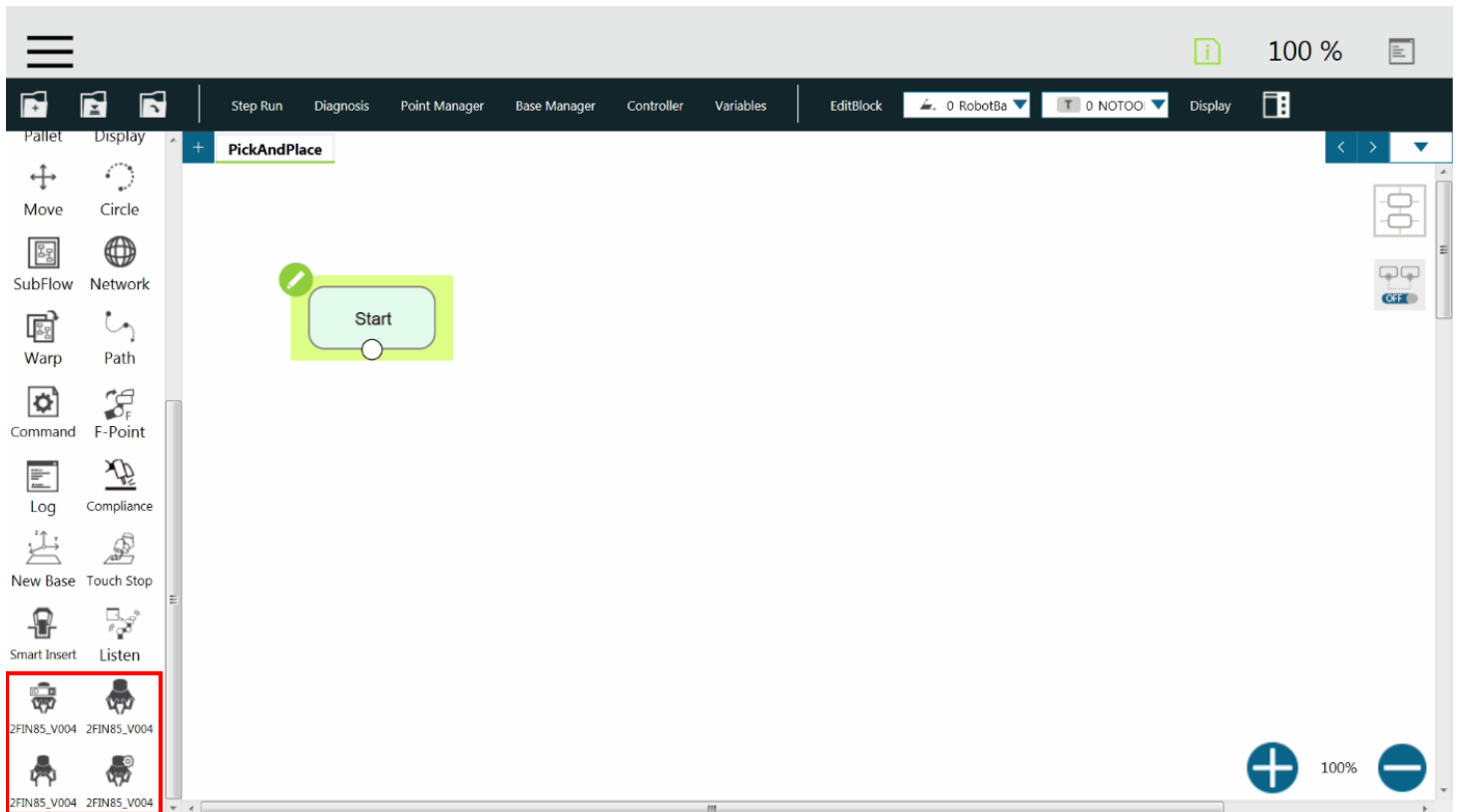

Gripper Button

The user can assign Gripper Components to the Gripper button and use the latter to open and close the fingers of the Robotiq Gripper.

- 1 From the TM Flow homepage, tap the **triple bar icon** and select the **Setting** icon

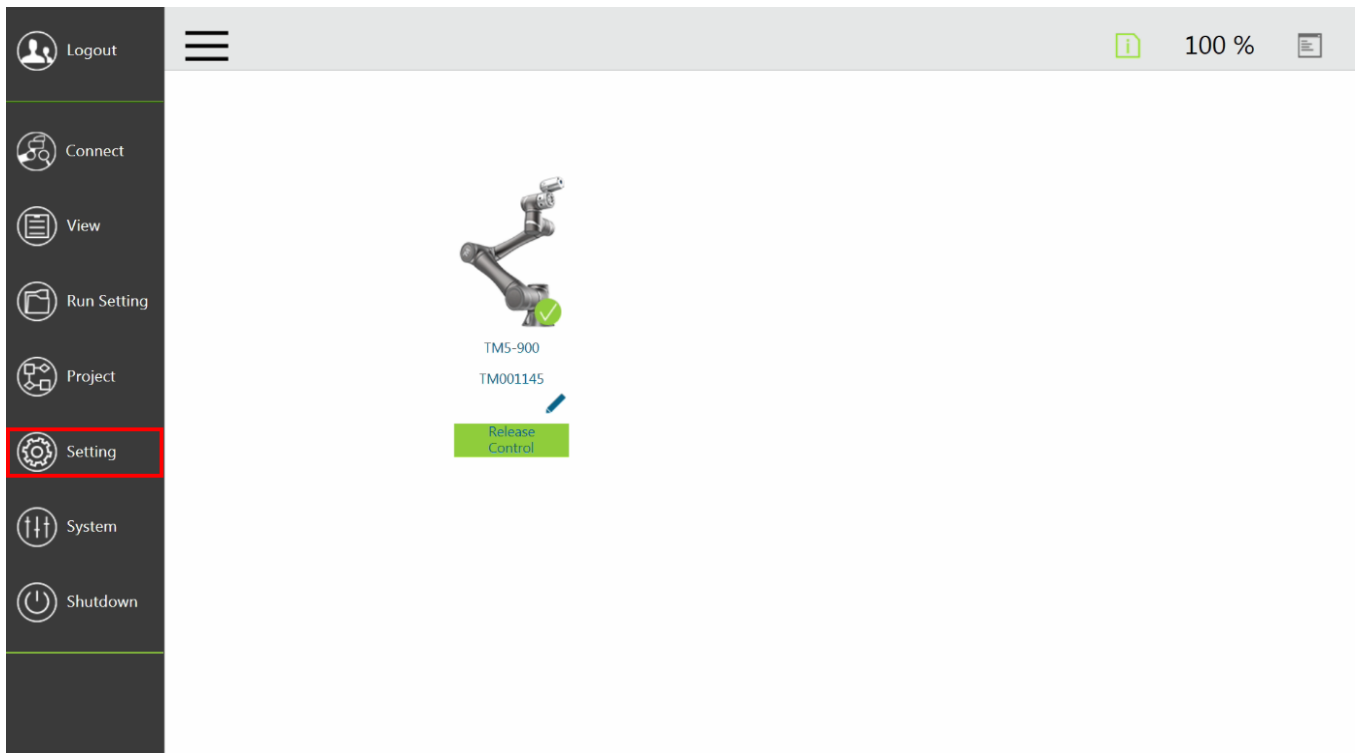

- 2 Click on **Gripper Button**

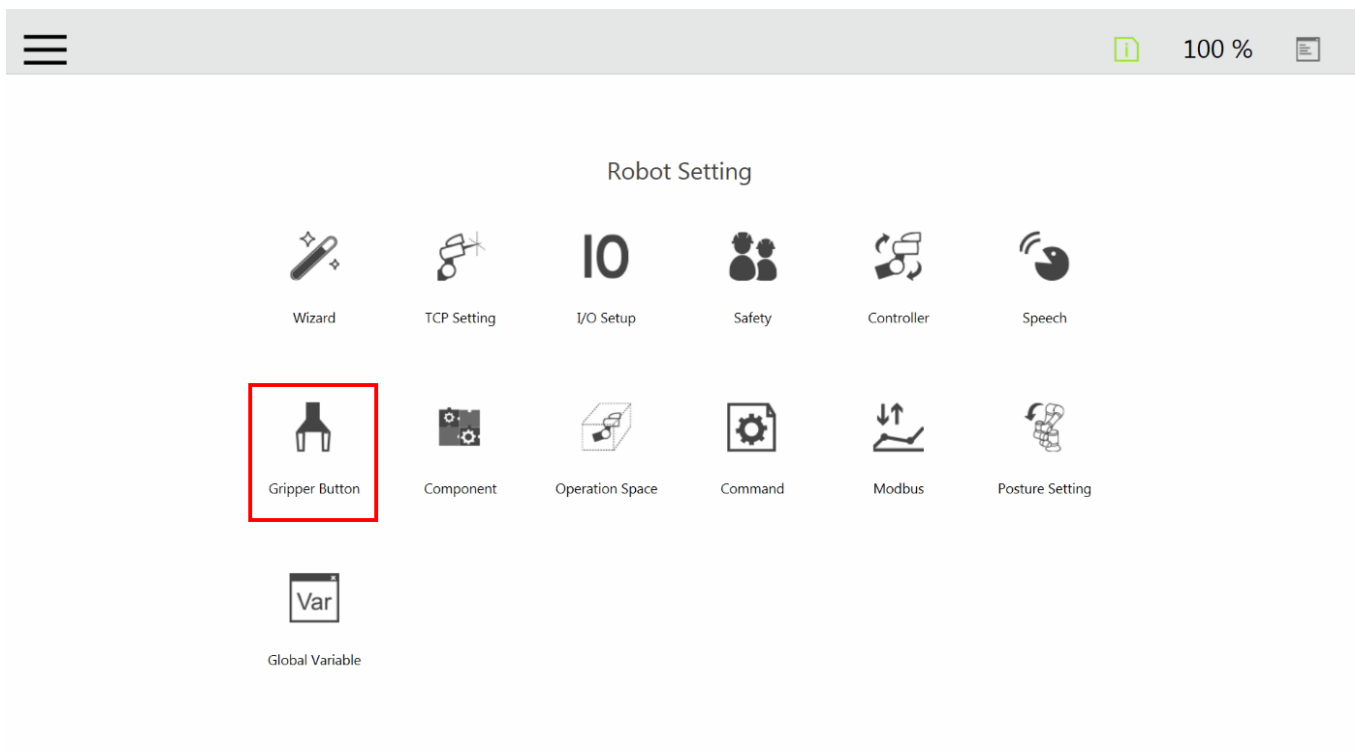

- In the **Gripper Button** window, tick the **Using Customized Component** radio button and select the Component you want to assign to either one of the Gripper actions

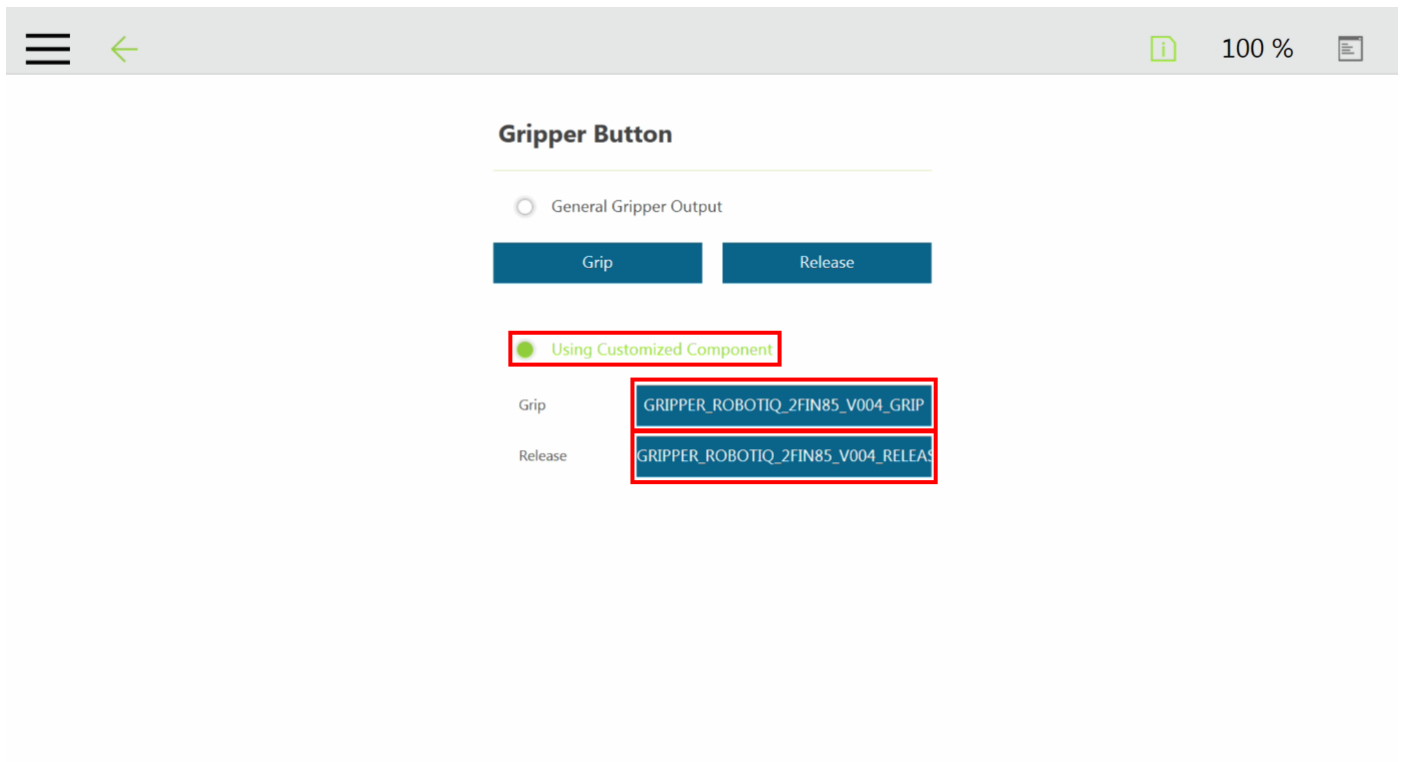

- In the popup window, select or change the Component you wish to assign to the Gripper action/button, and click **OK**

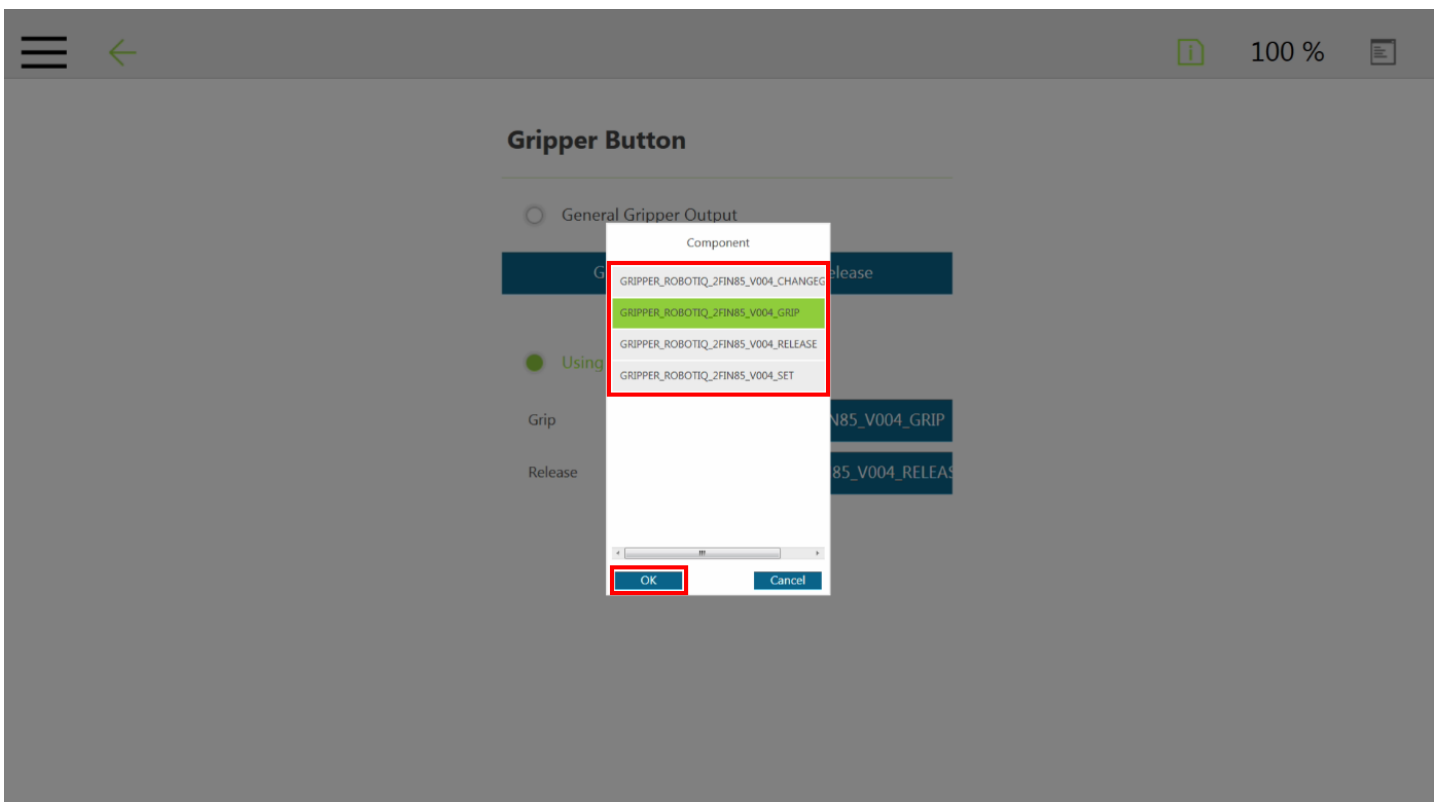

Programming

SET Component

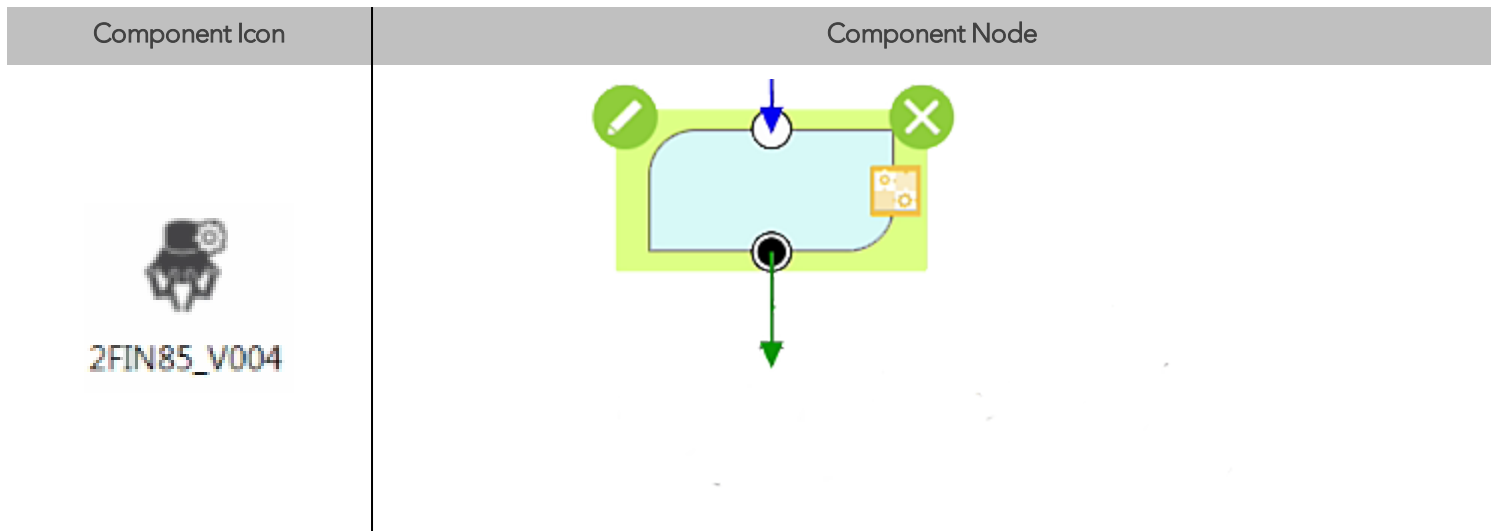

- 1 Drag and drop the SET Component icon after a program Gateway to place a SET program node (2FIN85_V004_SET1)
- 2 Tap the SET node to highlight it and click on the pencil to edit the settings

GRIPPER_ROBOTIQ_2FIN85_V004_SET ? X

Node Name

- Initialize_or_Not
>
- Release_Setting
>
- Grip_Setting
>
- ComPort_Setting
>

OK
Delete this node

Fig. 4-9: SET Node Settings Menu



Setting	Variable	Type	Default	Description	
Initialize_or_Not	var_reset	bool	false	Set True if you want to initialize the gripper in this node. If you only want to change gripping force, position or speed, you don't need to initialize the gripper (please set false)	
Grip_Setting	var_grip_force	%	50%	Set gripping force	
				2F-85	0~100%=20~235N
				2F-140	0~100%=10~125N
	var_grip_speed	%	50%	Set gripping speed	
				2F-85	0~100%=20~150mm/s
				2F-140	0~100%=30~250mm/s
	var_grip_pos	%	80%	Set gripping position	
				2F-85	0~100%=0~85mm/s
				2F-140	0~100%=0~140mm/s
Release_Setting	var_Release_force	%	50%	Set gripping force	
				2F-85	0~100%=20~235N
				2F-140	0~100%=10~125N
	var_Release_speed	%	50%	Set gripping speed	
				2F-85	0~100%=20~150mm/s
				2F-140	0~100%=30~250mm/s
	var_Release_pos	%	80%	Set gripping position	
				2F-85	0~100%=0~85mm/s
				2F-140	0~100%=0~140mm/s
ComPort_Setting	var_ComPort	int	1	Please set as Com1, Com2, Com3, following the com port to which you connect the gripper.	



GRIP Component

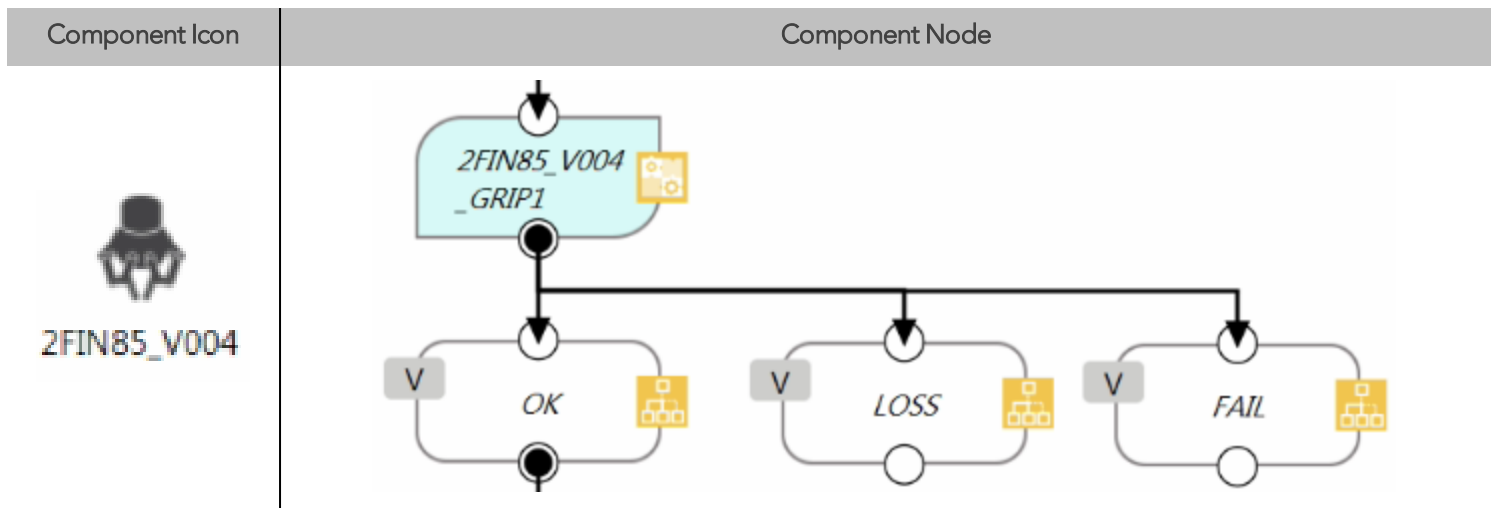

- 1 Drag and drop the GRIP Component icon after a program Gateway to place a GRIP program node (2FIN85_V004_GRIP1)
- 2 Tap the GRIP node to highlight it and click on the pencil to edit the settings

GRIPPER_ROBOTIQ_2FIN85_V004_GRIP ? ✕

Node Name

OK
Delete this node

Fig. 4-10: GRIP Node Settings Menu



Setting	Variable	Type	Default	Description	
Grip_Setting (SET Node)	var_grip_force	%	50%	Set gripping force	
				2F-85	0~100%=20~235N
				2F-140	0~100%=10~125N
	var_grip_speed	%	50%	Set gripping speed	
				2F-85	0~100%=20~150mm/s
				2F-140	0~100%=30~250mm/s
var_grip_pos	%	80%	Set gripping position		
			2F-85	0~100%=0~85mm/s	
			2F-140	0~100%=0~140mm/s	

RELEASE Component

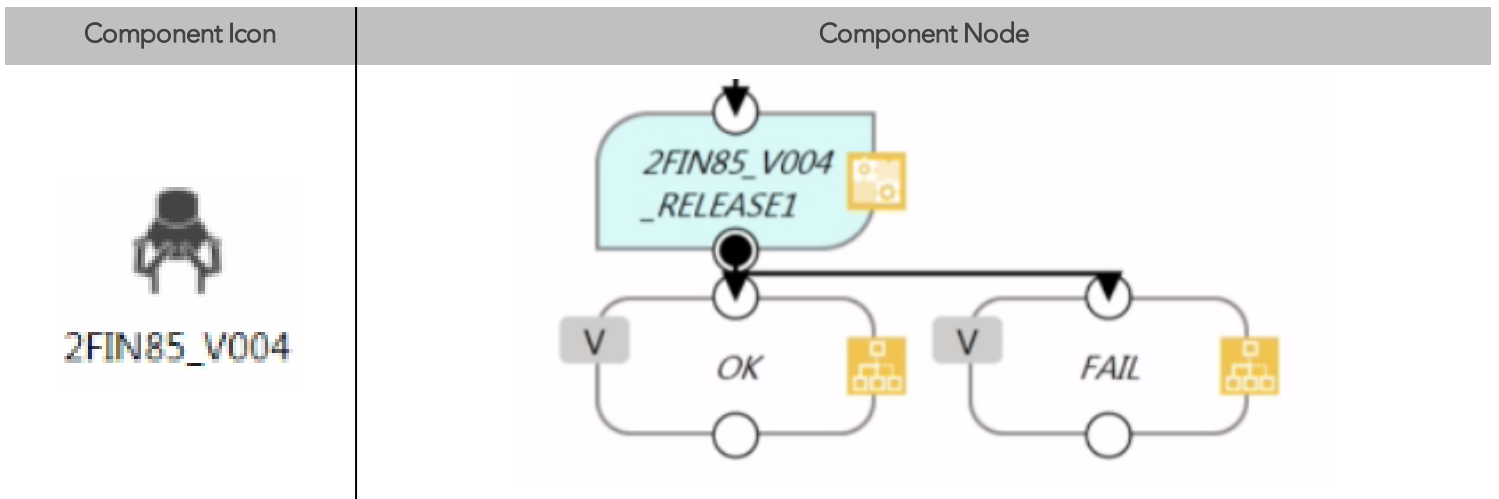

- 1 Drag and drop the RELEASE Component icon after a program Gateway to place a RELEASE program node (2FIN85_V004_RELEASE1)
- 2 Tap the RELEASE node to highlight it and click on the pencil to edit the settings

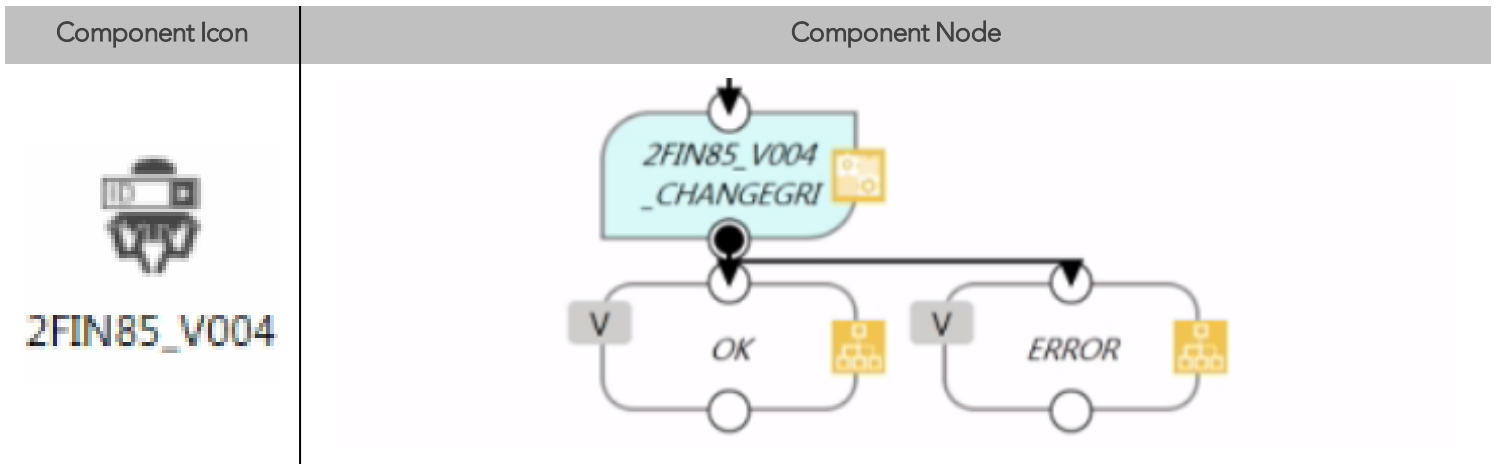

Fig. 4-11: RELEASE Node Settings Menu

Setting	Variable	Type	Default	Description	
Release_Setting (SET Node)	var_grip_force	%	50%	Set gripping force	
				2F-85	0~100%=20~235N
				2F-140	0~100%=10~125N
	var_grip_speed	%	50%	Set gripping speed	
				2F-85	0~100%=20~150mm/s
				2F-140	0~100%=30~250mm/s
	var_grip_pos	%	80%	Set gripping position	
				2F-85	0~100%=0~85mm/s
				2F-140	0~100%=0~140mm/s



CHANGEGRIPPER Component



- 1 Drag and drop the CHANGEGRIPPER Component icon after a program Gateway to place a CHANGEGRIPPER program node (2FIN85_V004_CHANGEGRIPPER)
- 2 Tap the CHANGEGRIPPER node to highlight it and click on the pencil to edit the settings

GRIPPER_ROBOTIQ_2FIN85_V004_CHANGEGRIPPER
?
×

Node Name

Change_Gripper
>

OK

Delete this node

Setting	Variable	Type	Default	Description
Change_Gripper	Var_Slave_ID	int	9	Select the Slave ID as the current gripper

Info

Use the Robotiq User Interface to change the Modbus Slave ID Address of the second gripper when using a dual gripper (Default = 9).



Changing the Modbus Slave ID

The user can change the Modbus Slave ID of a Robotiq Gripper via the Robotiq User Interface.

Installer

Browse to the [support page of the Gripper](#) in the Software section to download the RUI installer (.exe).

Robotiq User Interface

Browse to the support page of the Gripper, in the Documents section, to access or download the [instruction manual](#) of the Robotiq User Interface (RUI) for information on the installation and control of the RUI.

1 First, click on the **Modbus RTU Parameters** tab

Robotiq User Interface - 2-Finger Adaptive Robot Gripper

Connection View Help

Simple Control Device Information **Modbus RTU Parameters**

Initialization and Gripper Fault Status

Activate

Go to requested position

Auto-release : Direction Open

Interface Options

Control the Gripper using an Xbox Joystick

Demo Mode

Control Parameters

Pos. Request 100 /255

Speed 100 /255

Force 100 /255

Gripper Feedback

2-Finger-85



Object Detection

Position 204

Position

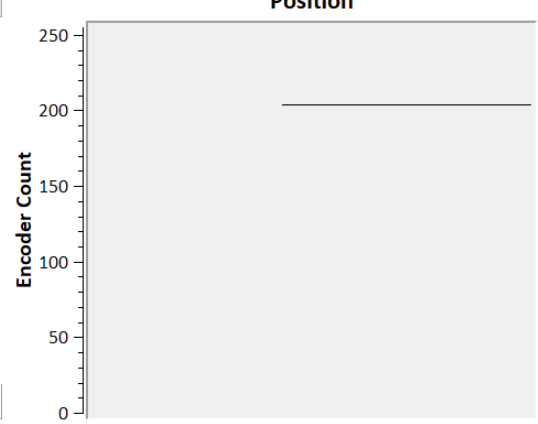

Current

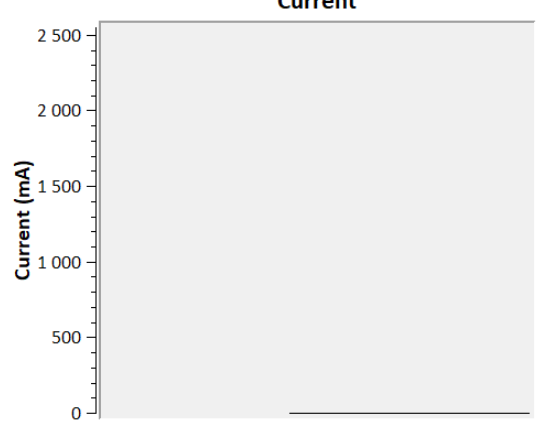

Connected to COM8. © 2011-2018 Robotiq. All rights reserved.



- 2 Change the Slave ID of the Gripper by typing in the corresponding box
- 3 Click on the Apply button

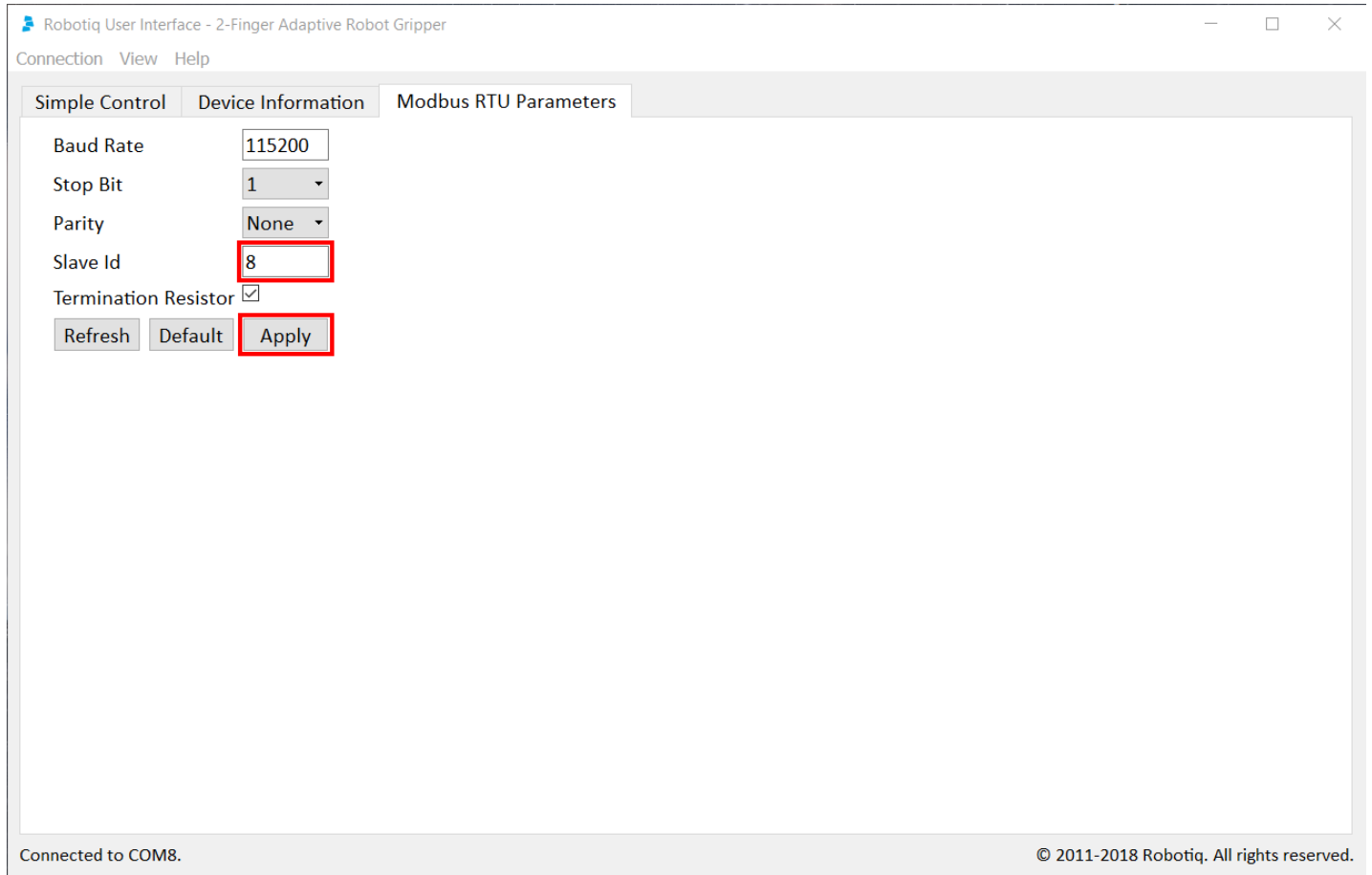

- 4 Perform a power cycle (24 V) while the USB device remains connected.



5. User Interface

Visit support.robotiq.com to get the latest installer of the Robotiq User Interface along with appropriate documentation.

See the [instruction manual of the Robotiq User Interface](#) for more details.



6. Specifications

Caution

The following manual uses the metric system, unless specified, **all dimensions are in millimeters**.

The following subsections provide data on the various specifications for the Robotiq 2-Finger 85 and 140 Adaptive Grippers.

- Section 6.1 lists the technical dimensions of the Grippers
 - Dimensions for custom (blank) coupling
 - Dimensions of all available couplings
 - Dimensions for custom fingertip
 - Dimensions of all available fingertips
- Section 6.2 presents the mechanical specifications of the Grippers.
- Section 6.3 gives electrical specifications for the Grippers.



6.1. Technical dimensions

The 2-Finger 85 and 2-Finger 140 share the same basic chassis and thus have the same technical dimensions for everything except the fingers. Figure 6-1 represents the Robotiq 2-Finger 85 Adaptive Robot Gripper's dimensions with axis X, Y, Z and origin referenced for finger motion. Figure 6-3 will show the equivalent with 140 mm fingers (2-Finger 140).

Info

All technical drawings in the present section are shown with silicone flat fingertip option: **AGC-TIP-204-085** (2-Finger 85) or **AGC-TIP-420-140** (2-Finger 140).

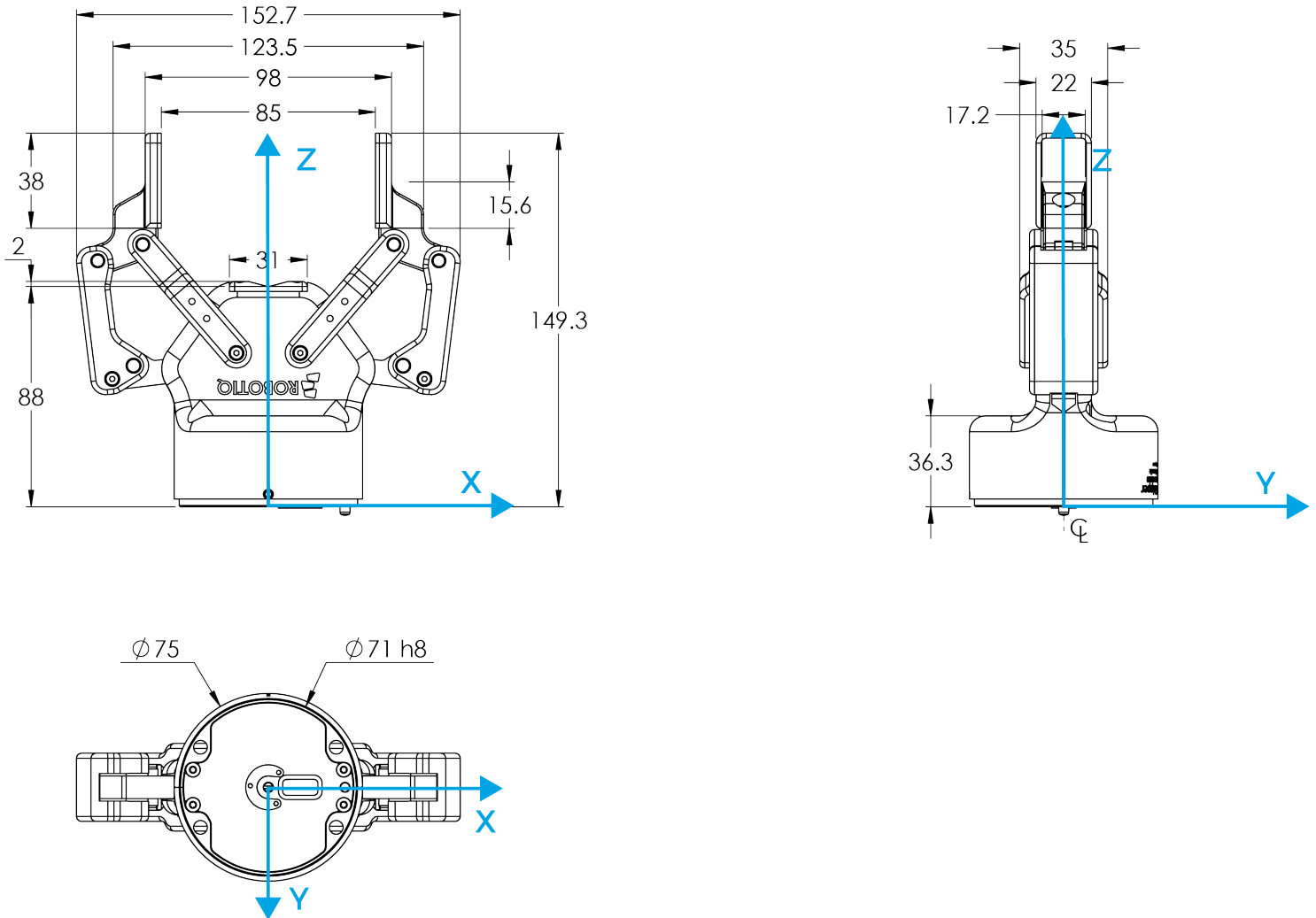

Fig. 6-1: 2F-85 general dimensions (opened).

As mentioned in the figure above, height and width of the fingers vary with opening position. Figure 6-1 represents the 2F-85 Gripper in the opened position (position request = 0), while Figure 6-2 represents the 2F-85 Gripper in the closed position (position request = 255).



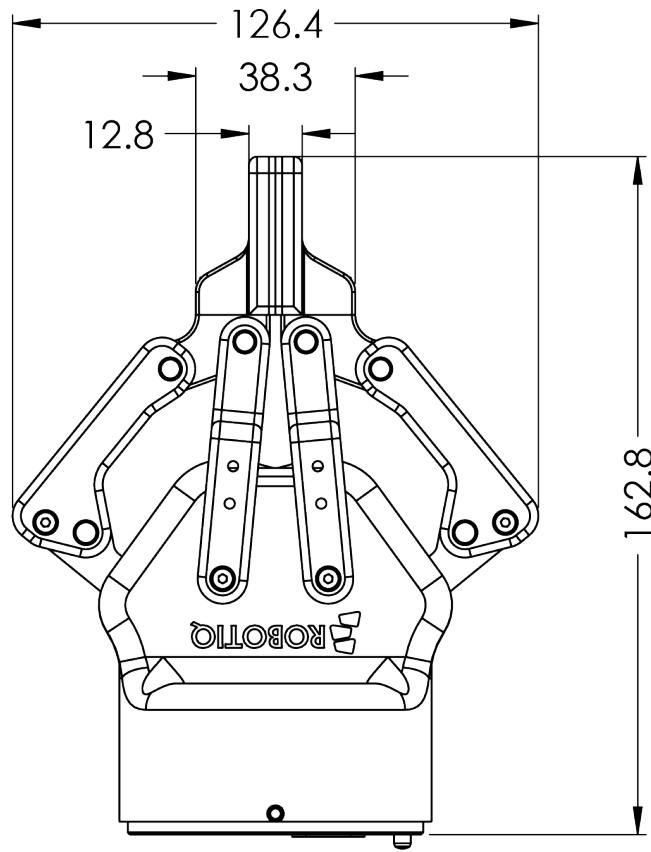

Fig. 6-2: 2F-85 dimensions (closed).



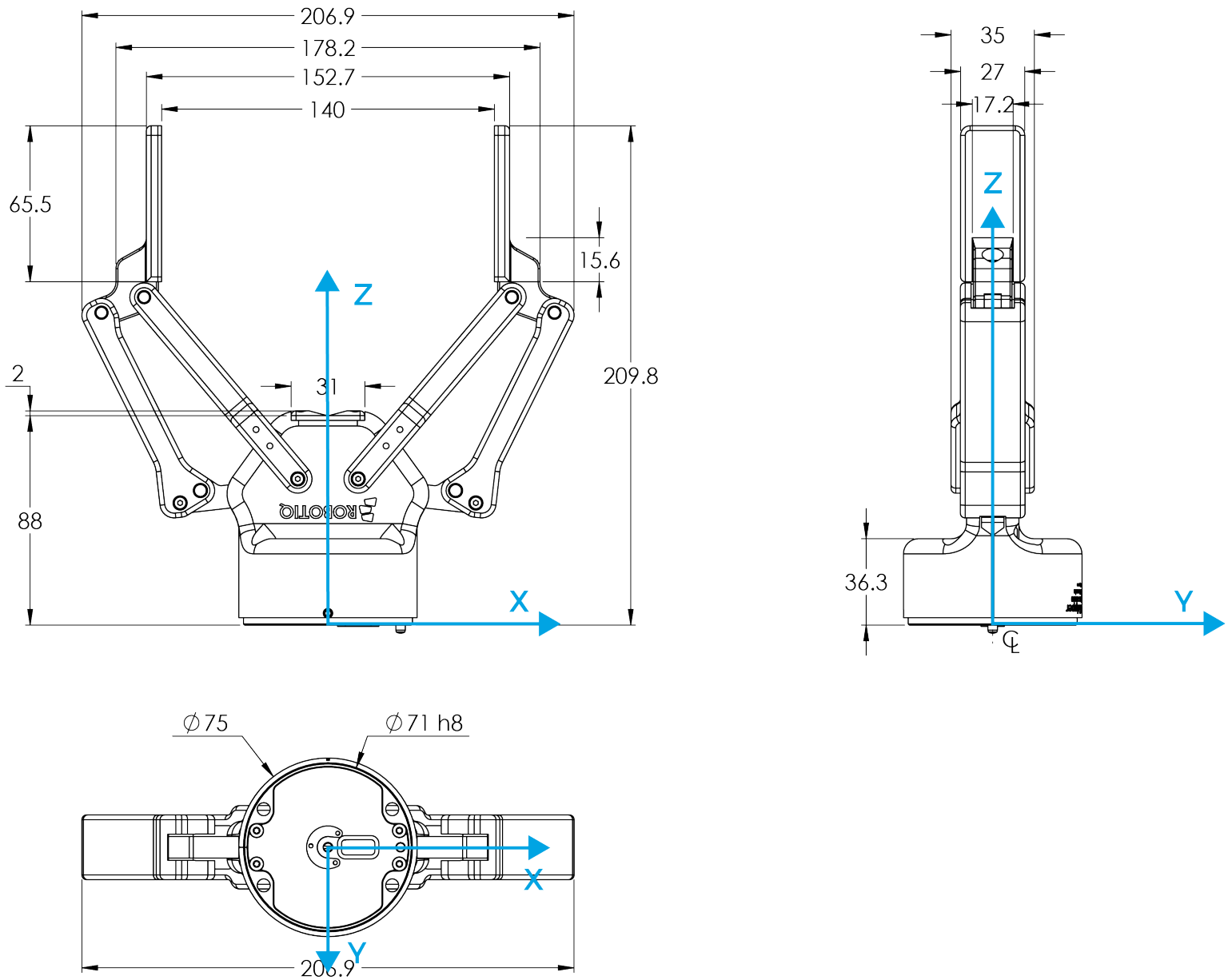

Fig. 6-3: 2F-140 general dimensions (opened).

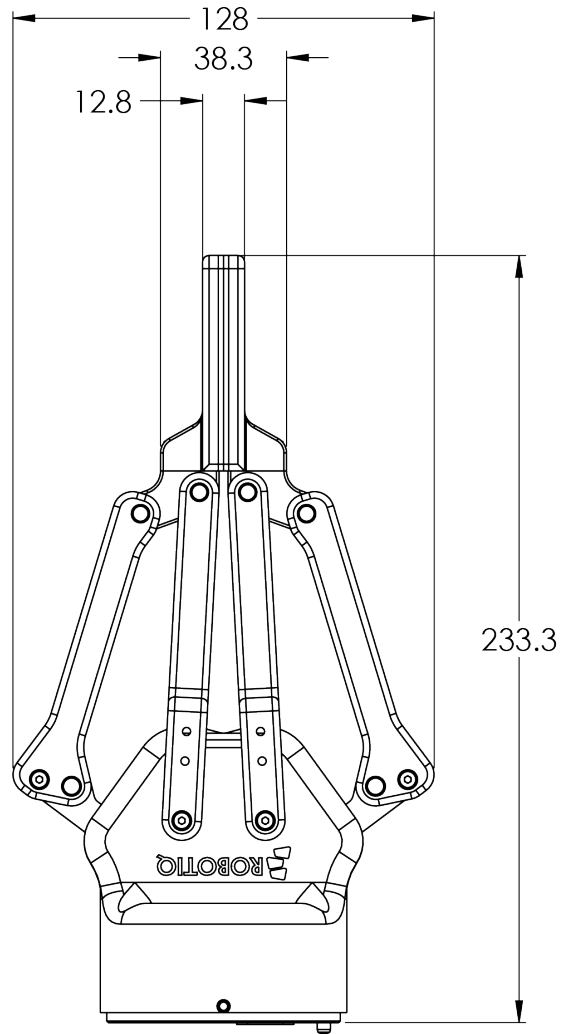

Fig. 6-4: 2F-140 dimensions (closed).

As mentioned in the figure above, the height and width of the fingers vary with opening position. Figure 6-3 represents the 2F-140 Gripper in the opened position (position request = 0), while Figure 6-4 represents the 2F-140 Gripper in the closed position (position request = 255).



6.1.1. Couplings

The Robotiq 2-Finger Adaptive Robot Gripper requires a coupling provided by Robotiq to operate. The coupling is mandatory since it integrates electronics and electrical contacts.

Info

The coupling is common to both the 2F-85 and the 2F-140.

Blank coupling

Below are the dimensions of the blank coupling, **AGC-CPL-BLANK-002** (refer to the **Spare Parts, Kits and Accessories** section), available to create a custom bolt pattern. Blue section can be fully customized (holes can be placed in any part of this section) while the grey section can only be worked to a depth of 3 mm.

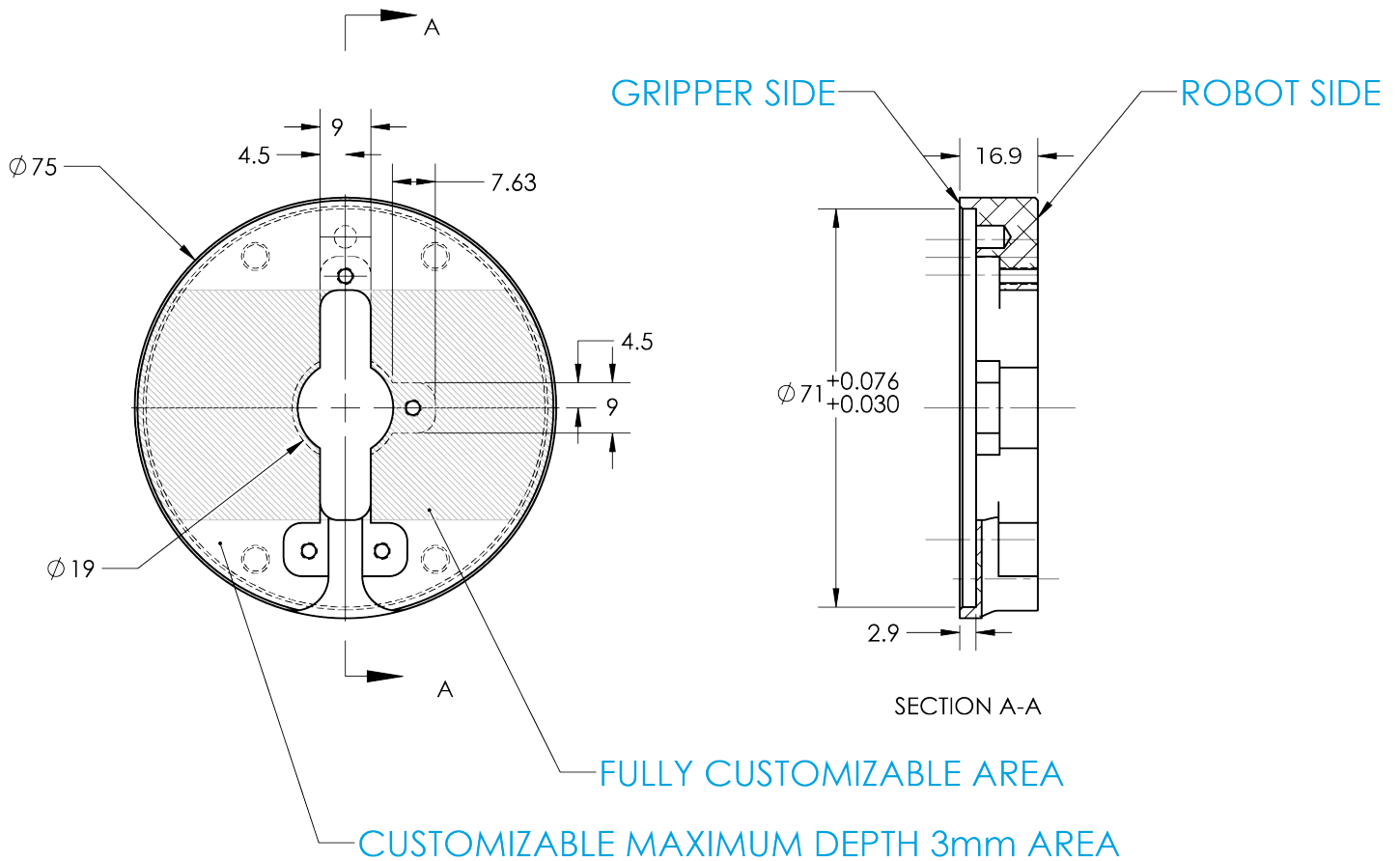

Fig. 6-5: Blank coupling AGC-CPL-BLANK-002 workable area dimensions.

Coupling for ISO 9409-1-50-4-M6

Bolt pattern for coupling AGC-CPL-062-002 (refer to the **Spare Parts, Kits and Accessories** section) is compatible with :

- 50 mm pitch circle diameter :
 - (4) M6-1.0 low head socket cap screw clearance
 - (1) M6 indexing pin
 - ISO 9409-1 standard 50-4-M6

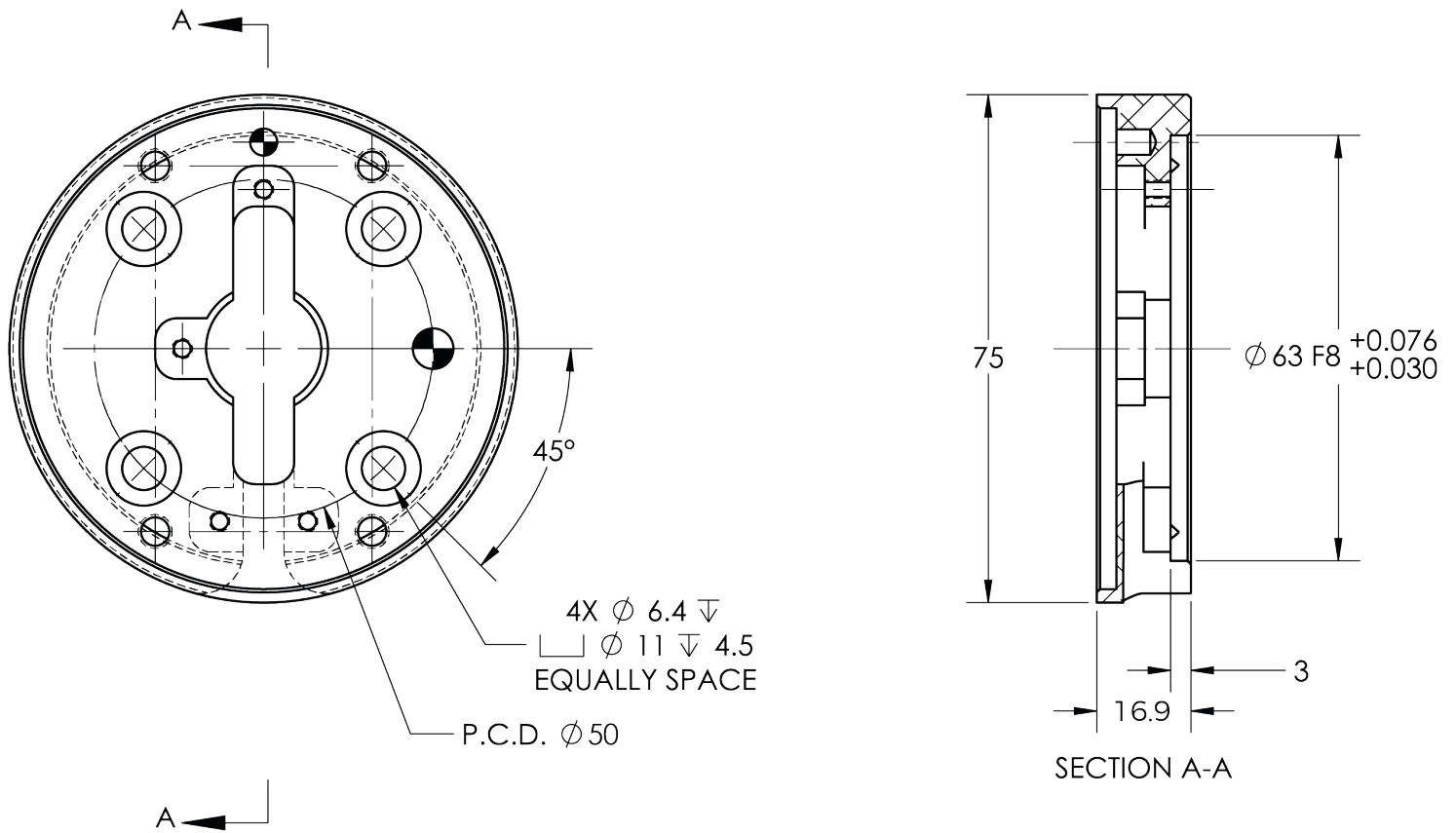

Fig. 6-6: Coupling for ISO 9409-1-50-4-M6.



Coupling for ISO 9409-1-40-4-M6

Bolt pattern for coupling AGC-CPL-064-002 (refer to the **Spare Parts, Kits and Accessories** section) is compatible with :

- 40 mm pitch circle diameter :
 - (4) M6-1.0 low head socket cap screw clearance
 - (1) M6 indexing pin
- ISO 9409-1 standard 40-4-M6

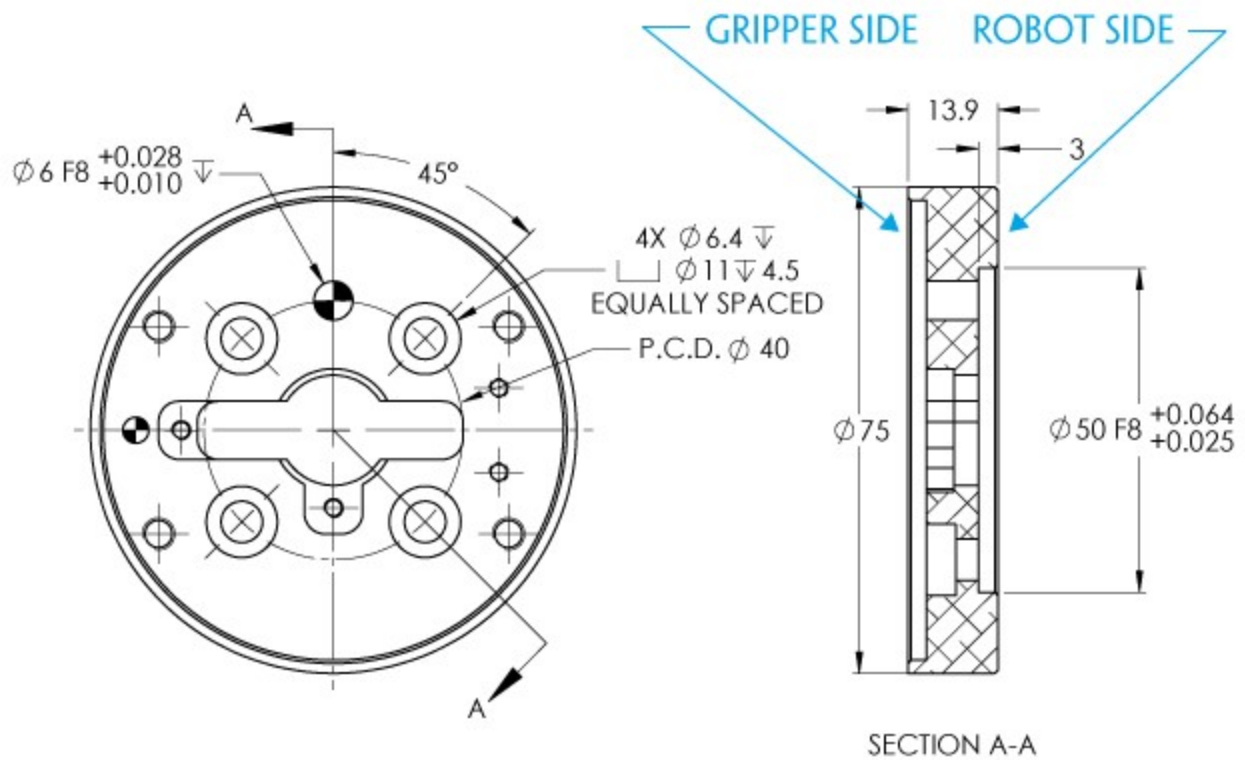

Fig. 6-8: Coupling for ISO 9409-1-40-4-M6.



Coupling for PCD 56 with 8 x M4

Bolt pattern for coupling AGC-CPL-065-002 (refer to the **Spare Parts, Kits and Accessories** section) is compatible with :

- 56 mm pitch circle diameter :
- (8) M4-0.7 low head socket cap screw clearance
- (1) M4 indexing pin
- 62 mm diameter internal insert

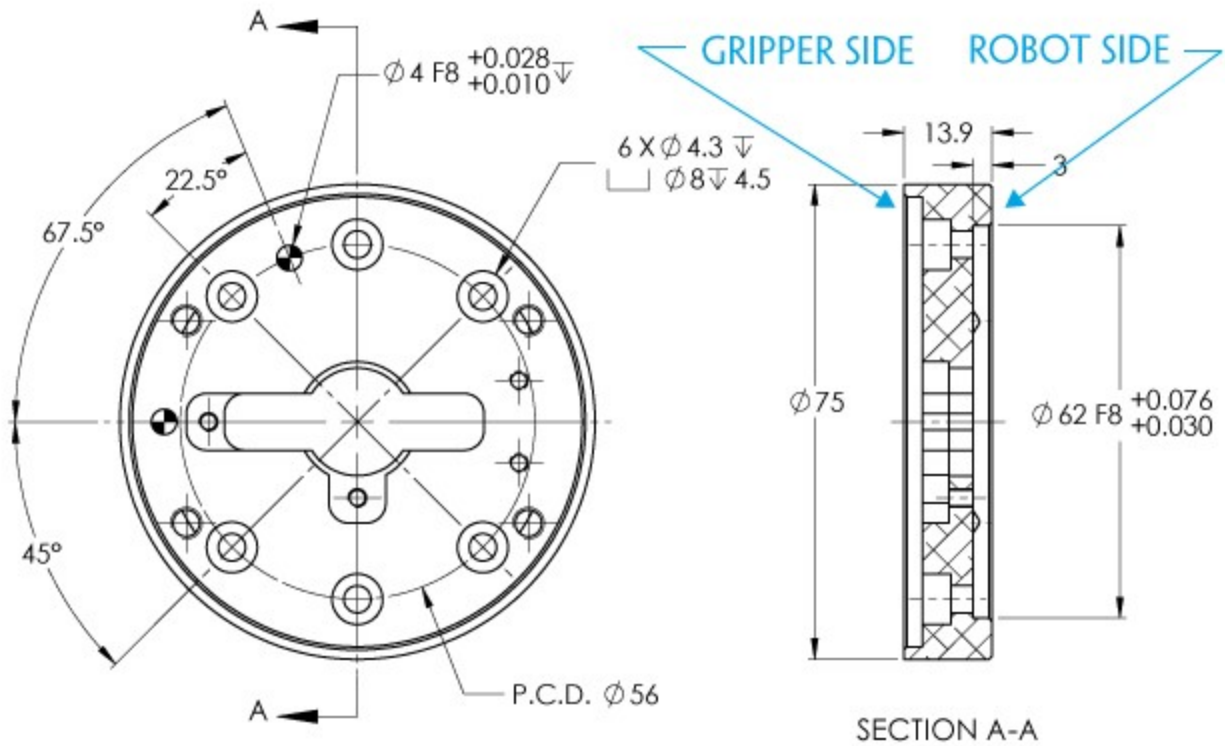

Fig. 6-9: Coupling for PCD 56 mm with 8 x M4 clearance.

Info

Although coupling AGC-CPL-065-002 is compatible with 8 x M4 threads on a 56 mm PCD it uses only 6 of the 8 normally present holes.

Coupling for PCD 56 with 6 x M4

Bolt pattern for coupling AGC-CPL-066-002 (refer to the **Spare Parts, Kits and Accessories** section) is compatible with:

- 56 mm pitch circle diameter:
 - (6) M4-0.7 low head socket cap screw clearance
 - (1) M6 indexing pin
 - 42 mm diameter external insert

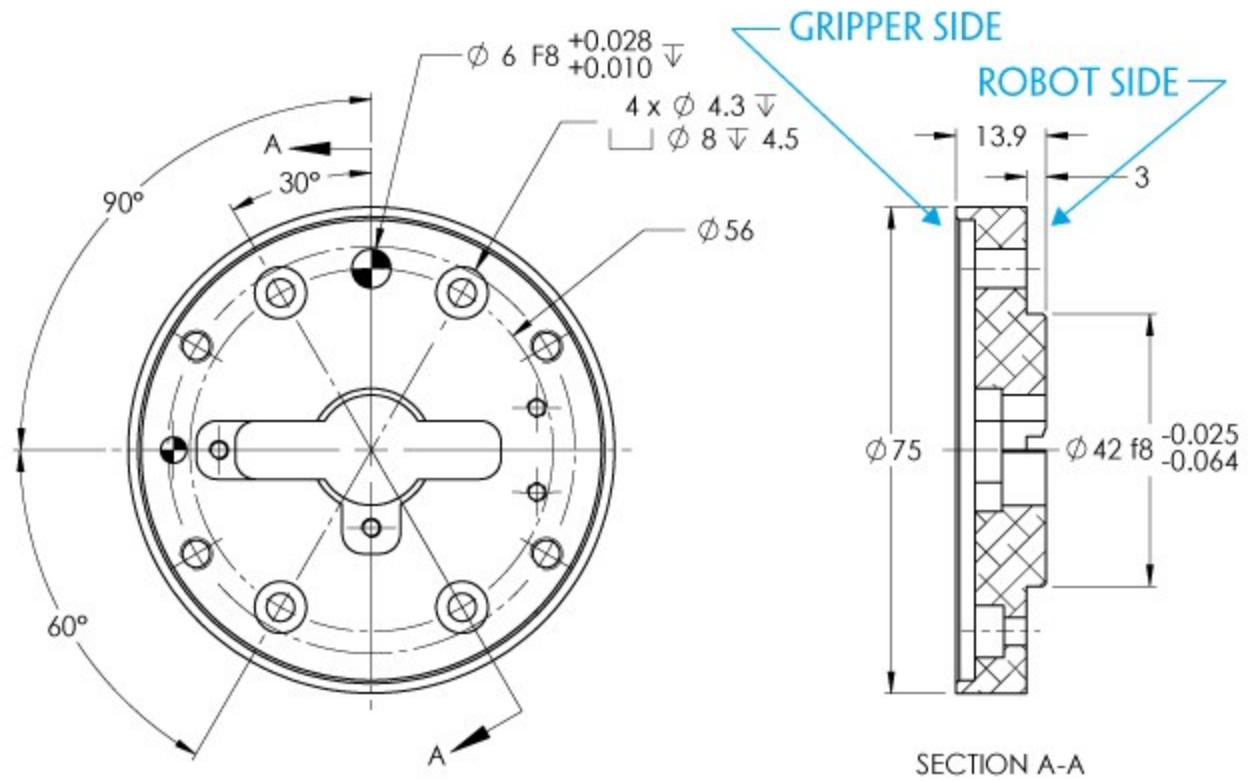

Fig. 6-10: Coupling for PCD 56 mm with 6 x M4 clearance.



Coupling for PCD 60 with 4 x M5

Bolt pattern for coupling AGC-CPL-067-002 (refer to the **Spare Parts, Kits and Accessories** section) is compatible with :

- 60 mm pitch circle diameter :
- (4) M5-0.8 low head socket cap screw clearance
- (1) M5 indexing pin
- 34 mm diameter external insert

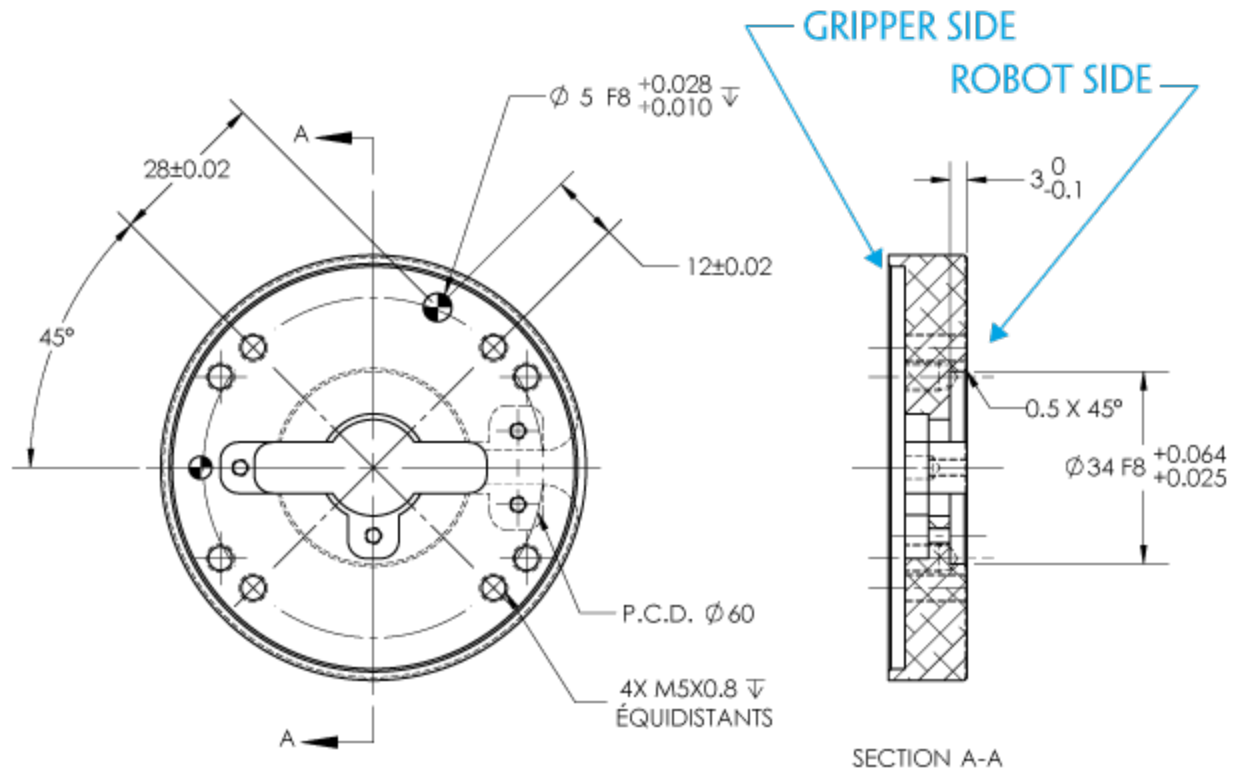

Fig. 6-11: Coupling for PCD 60 mm with 4 x M5 clearance.

Coupling for PCD 63 with 6 x M6

Bolt pattern for coupling AGC-CPL-068-002 (refer to the **Spare Parts, Kits and Accessories** section) is compatible with :

- 63 mm pitch circle diameter :
 - (6) M6-1.0 low head socket cap screw clearance
 - (2) M6 indexing pins

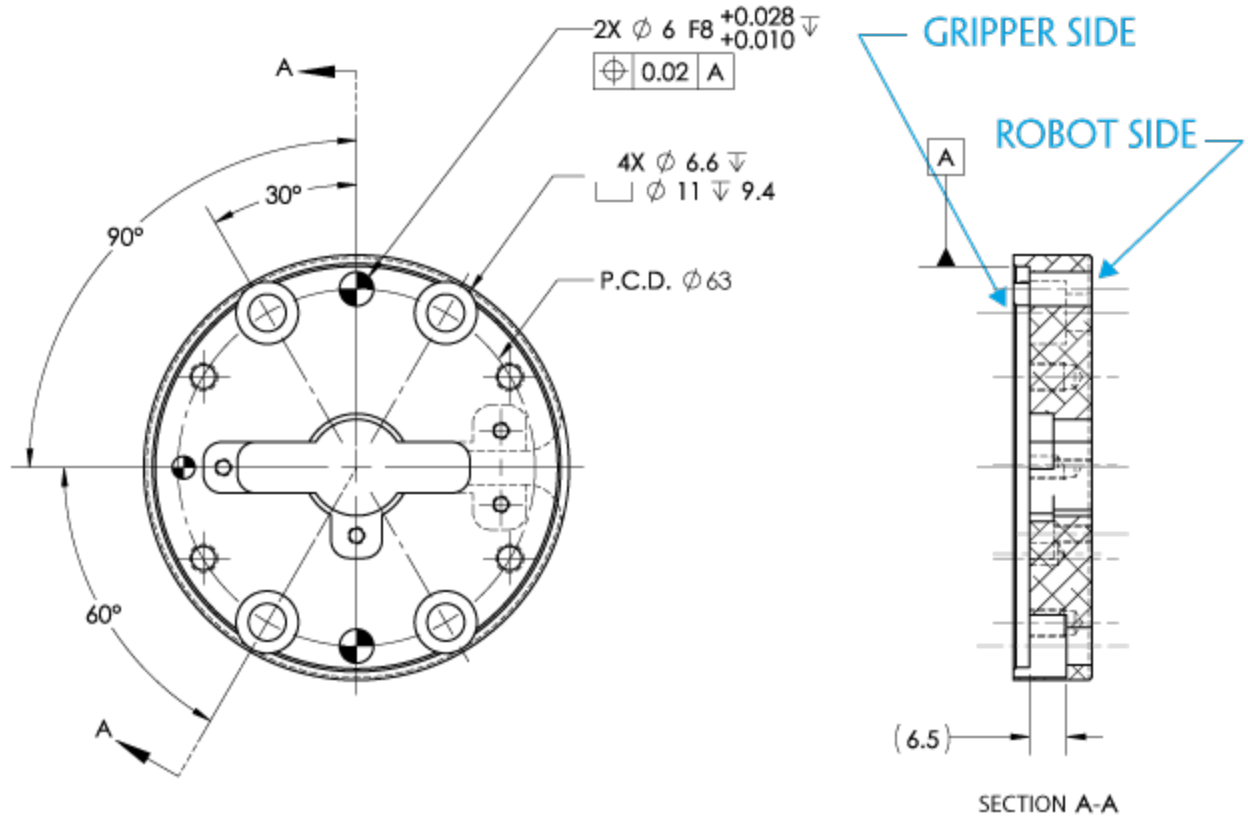

Fig. 6-12: Coupling for PCD 63 mm with 6 x M6 clearance.



6.1.2. Fingertips

The contact grasp points for the Robotiq 2-Finger Adaptive Robot Gripper are its two fingertip pads and palm pad. Many fingertips are available from Robotiq (refer to the **Spare Parts, Kits and Accessories** section). The user can customize their own fingertips from blanks or create them from scratch. The figure below represents the distal phalanx (which acts as the fingertip holder) the permanent, non customizable part of the Gripper finger on which the fingertip must be mounted.

Custom fingertip designs must abide by the following:

- Fingertip must not exceed 100 mm in height from the fingertip's base.
- Fingertip must not exceed 100 mm in width from the fingertip's base (refer to Y axis from figure 6-18).
- Refer to the **Mechanical specifications** section to evaluate the grasp force according to your fingertip design.
- Applied forces to the gripper must not exceed moment and force limits detailed in the **Moment and force limits** section.

Info

Both 2-Finger 85 and 2-Finger 140 use the same fingertips and finger holder.

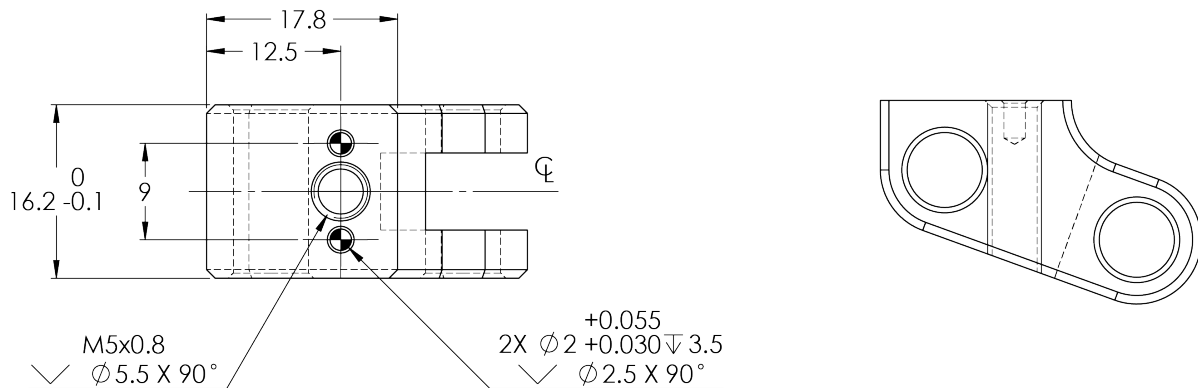

Fig. 6-13: Distal phalanx for holding standard or custom fingertips.

Tip

Custom fingertips will still be subject to the equilibrium line rule for proper actuation of the Gripper, see General Presentation section.



Flat silicone fingertip

The figure below represents a flat silicone fingertip **AGC-TIP-204-085** (2F-85) and **AGC-TIP-420-140** (2F-140); please refer to the **Spare Parts, Kits and Accessories** section. This fingertip has a flat silicone surface with an optimal friction coefficient for picking objects while the other surface will mount onto the fingertip holder shown in the **Fingertips** section.

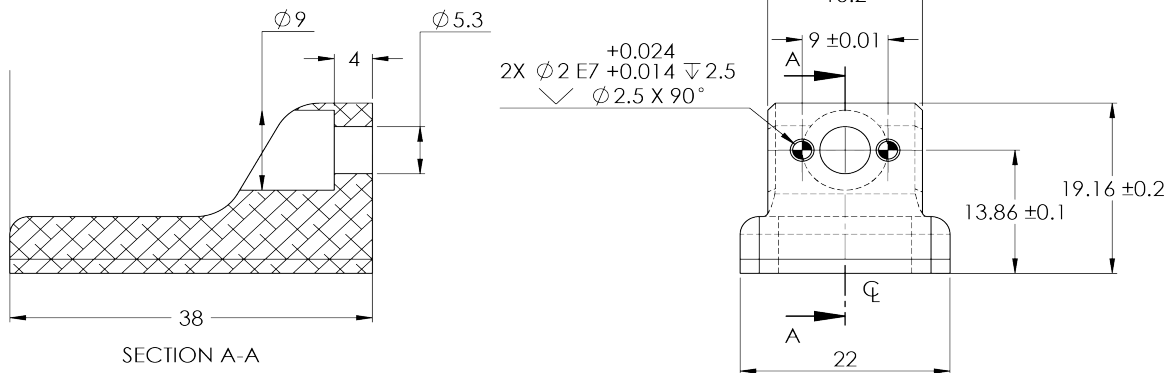

Fig. 6-14: Flat silicone fingertip AGC-TIP-204-085

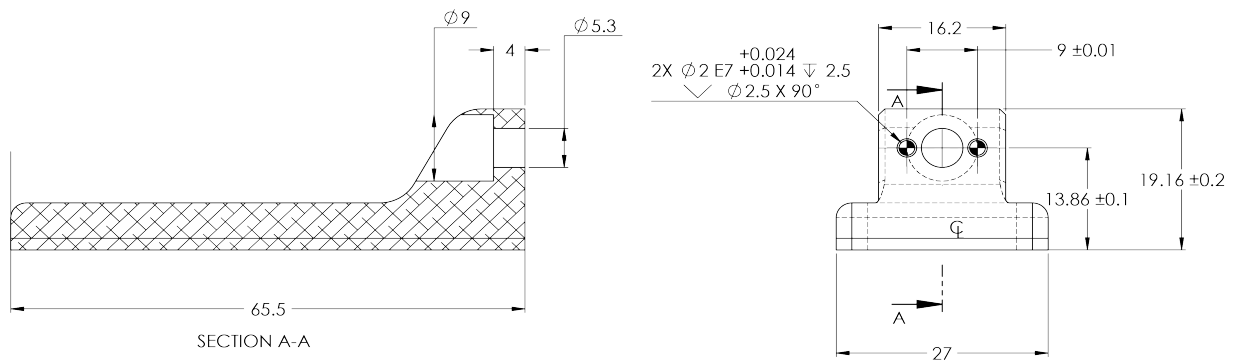

Fig. 6-15: Flat silicone fingertip AGC-TIP-420-140



Grooved fingertip

The figure below represents the available grooved fingertip **AGC-TIP-205-085** (2-Finger 85) and **AGC-TIP-421-140** (2-Finger 140); please refer to the **Spare Parts, Kits and Accessories** section. This fingertip has a grooved surface with an optimal shape for picking cylindrical objects (with its horizontal and vertical grooves) while the other surface will mount onto the fingertip holder shown in the **Fingertips** section.

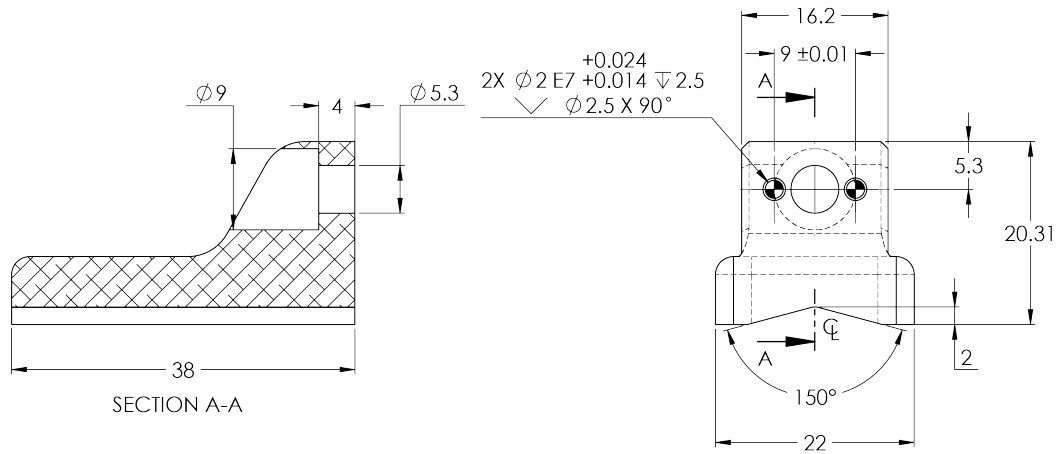

Fig. 6-16: Grooved fingertip AGC-TIP-205-085

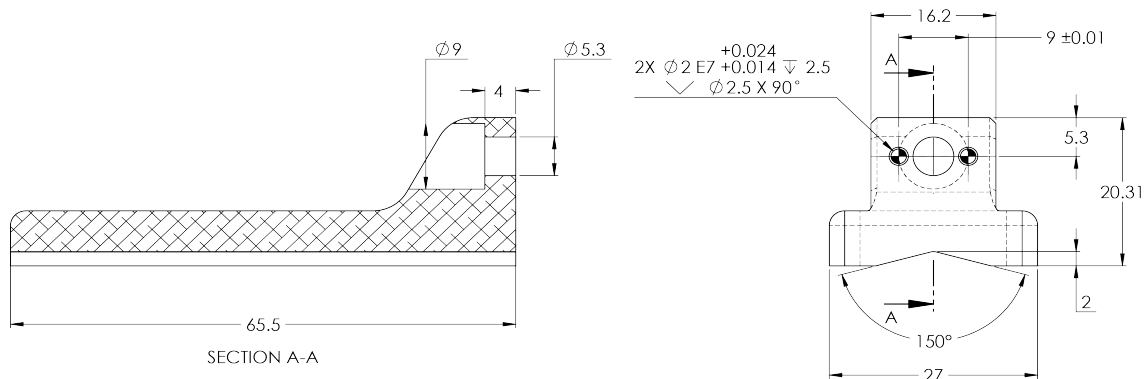

Fig. 6-17: Grooved fingertip AGC-TIP-421-140

6.2. Mechanical specifications

Specification	2-FINGER 85		2-FINGER 140	
	Metric Units	Imperial Units	Metric Units	Imperial Units
Gripper Opening	85 mm	3.35 in	140 mm	5.5 in
Minimum object diameter (for encompassing)	43 mm	1.69 in	90 mm	3.5 in
Maximum height	162.8 mm	6.4 in	232.8 mm	9.15 mm
Maximum width	148.6 mm	5.85 in	202.1 mm	8.0 in
Weight	925 g	2.04 lbs	1,025 g	2.25 lbs
Grasp Force	20 to 235 N	4.5 to 52.8 lbf	10 to 125 N	2.2 to 28.1 lbf
Finger speed	20 to 150 mm/s	0.8 to 5.9 in/s	30 to 250 mm/s	1.2 to 9.8 in/s
Position repeatability ¹	0.05 mm	0.002 in	0.08 mm	0.003 in
Force repeatability	+/- 10%			
Position resolution ²	0.4 mm	0.016 in	0.6 mm	0.022 in
Grasp force resolution	Maximum force calculation below; refer to the Force control section			

Info

All specs are measured with coupling **GRP-CPL-062** and fingertip **AGC-TIP-204-085** (2-Finger 85) or **AGC-TIP-420-140** (2-Finger 140).

¹Repeatability is defined as the positional deviation resulting from the average displacement determined when picking an object with a parallel grasp using standard silicone fingertips. For more details see the blog.robotiq.com article on repeatability. Position repeatability varies depending on the product wear and operating conditions. The presented values are typical for the newly-manufactured products.

²Resolution is the increment modified from a 1 bit difference of position/speed/force request (from 0 to 255).



6.2.1. Payload and force

Actuation force model used to calculate recommended payload is described in the figure below, the user must not exceed the force and torque limits:

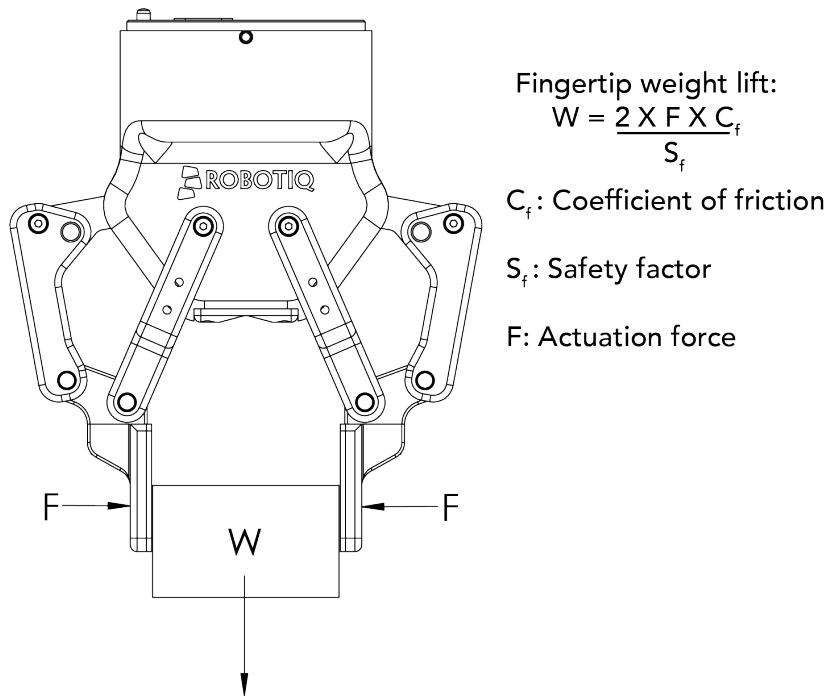

Fig. 6-18: Actuation force on the fingertip of the Adaptive Gripper 2-Finger (see charts below for 2-Finger 85 and 2-Finger 140 force).

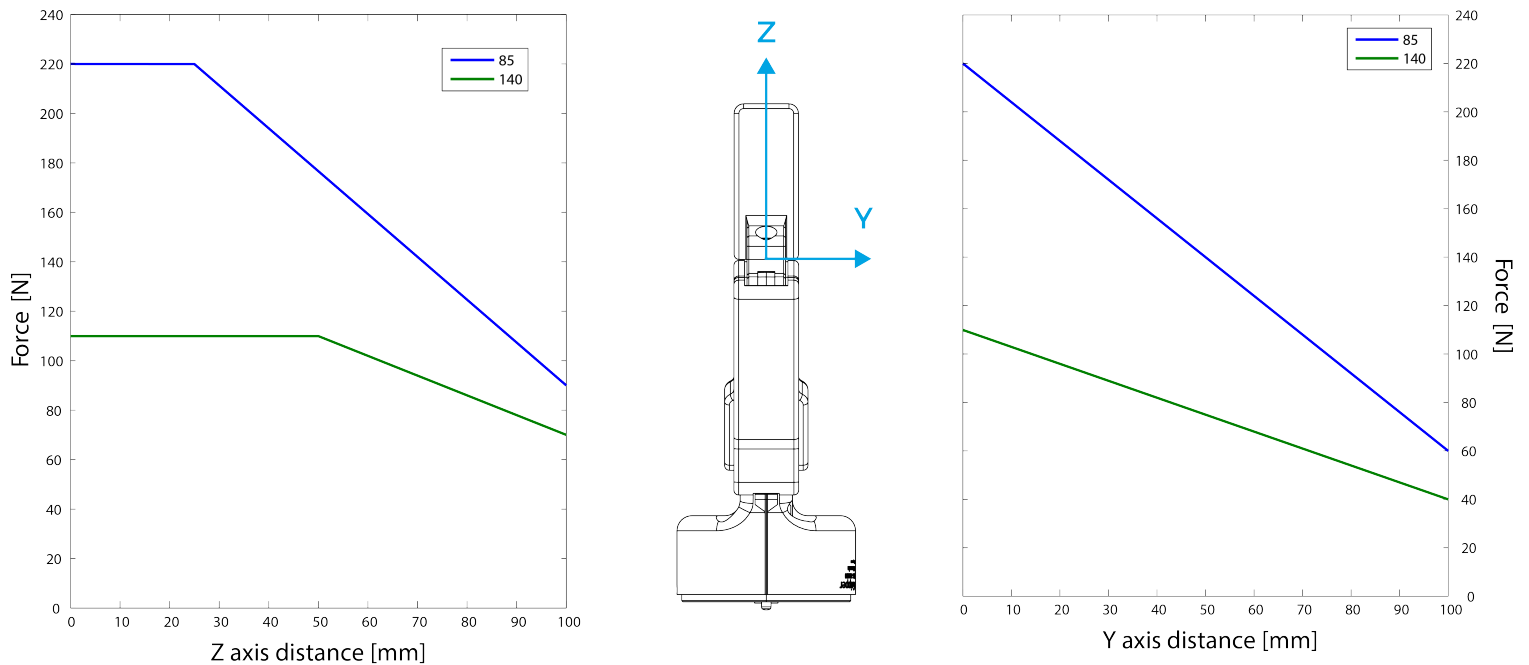

Fig. 6-19: Grasp force in the Y and Z axis for the 2-Finger 85 and 2-Finger 140.

Info

- The "Actuation Force" is the force that can be applied to an object by the motor of the Gripper.
- The Gripper is self-locking.

Info

The user of the Gripper must always ensure that the result of the forces against the finger is always lower than the maximum holding force as seen in figure 6-18.

As defined in figure 6-18, the weight that can be lifted is defined by :

- F is the force that is applied to the load by the Gripper.
- Cf is the friction coefficient between the fingertip and the object load.
- Sf is a safety factor to be determined by the robot integrator.

Info

For example, if the silicone fingertips **AGC-TIP-204** are used to lift a lubricated steel object (machine tending with cutting oils), the friction coefficient would be 0.3 (tested static coefficient of friction).

Maximum weight with a safety factor of 2.4 would be :

$$W = (2 \times 200 \text{ N} \times 0.3) / 2.4 = 50 \text{ N}$$

This calculation means that a 5 kg object will be held by the Gripper when not moving (standing still). When accelerating, the payload will decrease.

For example, if your robot accelerates at 2g then the 5 kg object would weigh 100 N and would therefore be dropped.

The biggest factor in such calculations will always be the friction coefficient, we recommend testing the coefficient.

Warning

You must consider the **robot acceleration** in your payload calculations.
Robot emergency stops will lead to major deceleration velocities.



Friction grasp and form-fit grasp

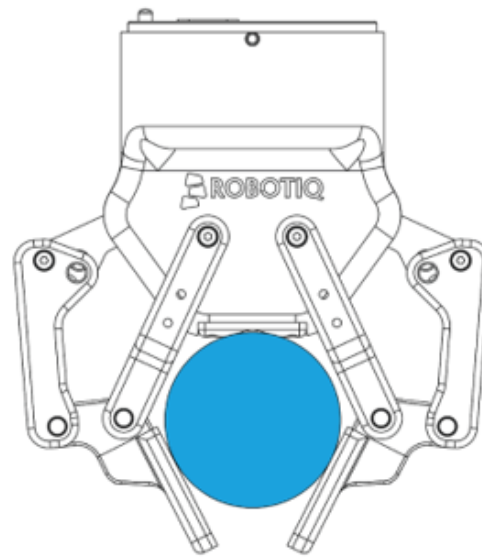
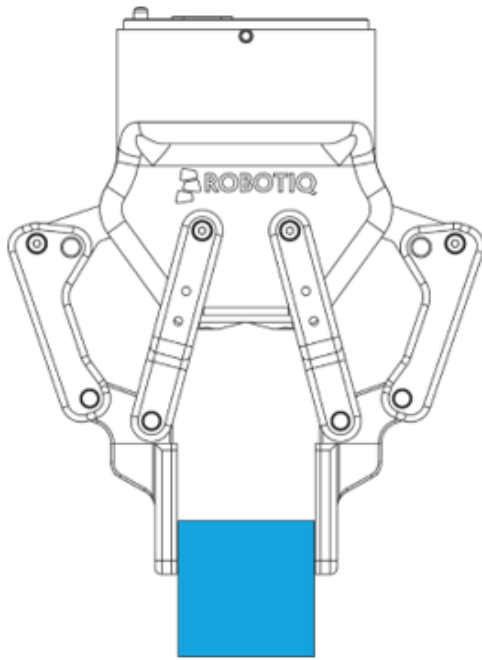

Maximum payload by grasp type

Grasp Type	2F-85	2F-140
Friction grasp	5 kg	2.5 kg
Form-fit grasp	5 kg	2.5 kg

6.2.2. Equilibrium Line

Equilibrium line position (explained in the **General Presentation** section) is detailed in the figure below, where:

- θ is the opening angle between the Gripper proximal bar and center line
- d is the distance between the bottom of the finger pads and the equilibrium line as seen on the Z axis in figure 1-5.

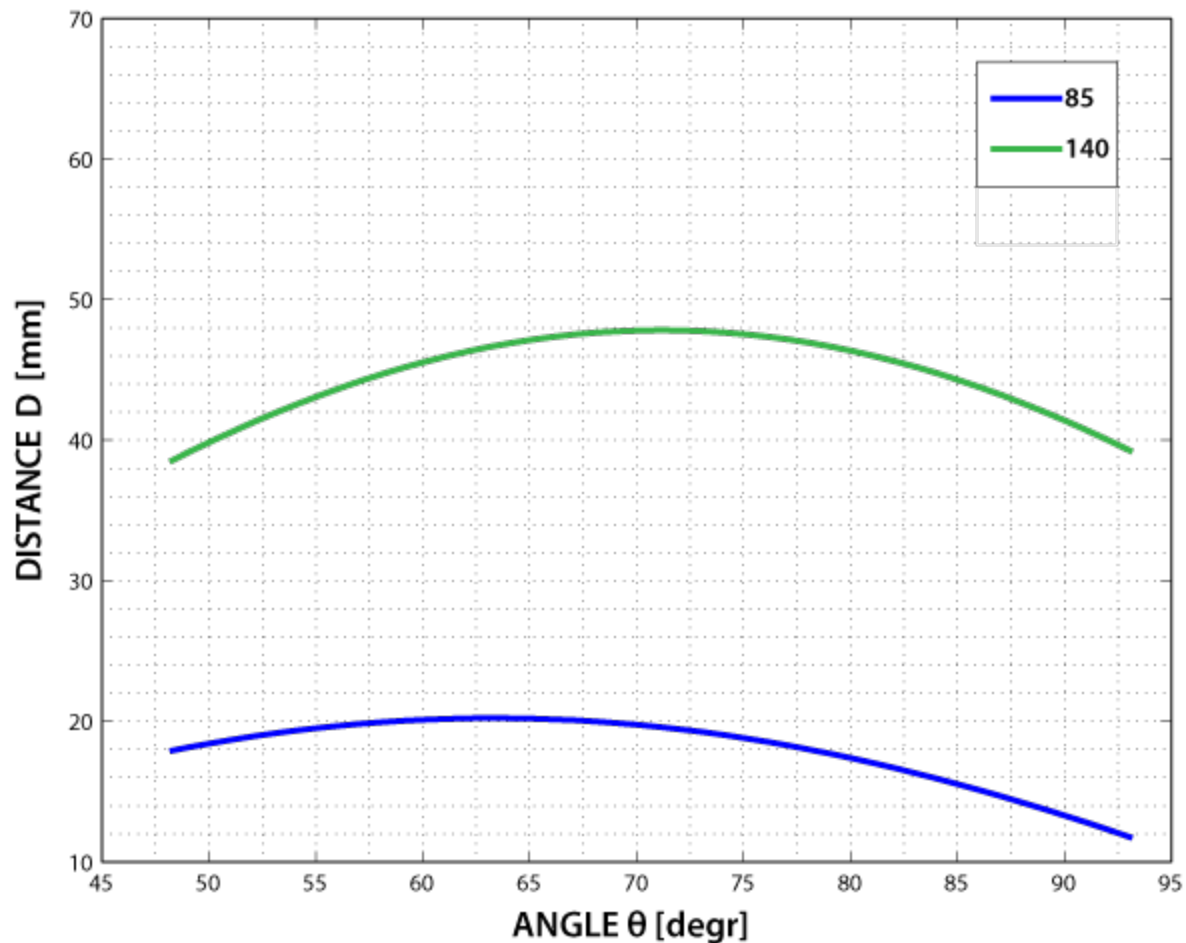

Fig. 6-20: Position of the Gripper equilibrium line according to the opening angle for 2-Finger 85 and 2-Finger 140 options.



6.2.3. Center of mass, tool center point and moment of inertia

Coupling is included when Gripper is not mounted on the Camera. Dual Gripper adapter plate included where appropriate.

Products	Center of mass (mm)			TCP (mm)						Mass (g)
	X	Y	Z	Gripper 1			Gripper 2			
				X	Y	Z	X	Y	Z	
FT Sensor	-3.0	0.0	17.0	0.0	0.0	37.5	-	-	-	300.0
Camera	-3.0	4.5	9.0	0.0	0.0	23.5	-	-	-	245.0
2F-85	0.0	0.0	58.0	0.0	0.0	174.0	-	-	-	925.0
2F-140	0.0	0.0	73.0	0.0	0.0	244.0	-	-	-	1025.0
Hand-E	0.0	0.0	57.5	0.0	0.0	157.0	-	-	-	1090.0
Dual grippers plate	0.0	0.0	15.5	-	-	-	-	-	-	265.0
FT Sensor + 2F-85	-0.7	0.0	76.3	0.0	0.0	211.5	-	-	-	1225.0
FT Sensor + 2F-140	-0.7	0.0	89.3	0.0	0.0	281.5	-	-	-	1325.0
FT Sensor + Hand-E	-0.6	0.0	78.2	0.0	0.0	194.5	-	-	-	1390.0
Camera + 2F-85	-0.7	1.2	57.1	0.0	0.0	175.5	-	-	-	975.0
Camera + 2F-140	-0.7	1.1	72.4	0.0	0.0	246.5	-	-	-	1075.0
Camera + Hand-E	-0.6	1.0	57.4	0.0	0.0	159.5	-	-	-	1135.0
FT Sensor + Camera + 2F-85	-1.3	0.9	76.3	0.0	0.0	213.0	-	-	-	1275.0
FT Sensor + Camera + 2F-140	-1.2	0.8	89.6	0.0	0.0	284.0	-	-	-	1375.0
FT Sensor + Camera + Hand-E	-1.1	0.8	78.6	0.0	0.0	197.0	-	-	-	1435.0
Hand-E/Hand-E	0.0	0.0	62.0	154.0	0.0	138.0	-154.0	0.0	138.0	2445.0
Hand-E/2F-85	5.9	0.0	61.7	154.0	0.0	138.0	-166.0	0.0	150.0	2280.0
Hand-E/2F-140	-2.4	0.0	66.6	154.0	0.0	138.0	-215.5	0.0	199.5	2380.0
2F-85/2F-85	0.0	0.0	61.4	166.0	0.0	150.0	-166.0	0.0	150.0	2115.0
2F-85/2F-140	-8.7	0.0	66.6	166.0	0.0	150.0	-215.5	0.0	199.5	2215.0
2F-140/2F-140	0.0	0.0	71.4	215.5	0.0	199.5	-215.5	0.0	199.5	2315.0
Camera + Hand-E/Hand-E	-0.3	0.4	78.5	154.0	0.0	161.5	-154.0	0.0	161.5	2690.0
Camera + Hand-E/2F-85	5.0	0.4	77.8	154.0	0.0	161.5	-166.0	0.0	173.5	2525.0
Camera + Hand-E/2F-140	-2.5	0.4	82.5	154.0	0.0	161.5	-215.5	0.0	223.0	2625.0
Camera + 2F-85/2F-85	-0.3	0.5	77.0	166.0	0.0	173.5	-166.0	0.0	173.5	2360.0
Camera + 2F-85/2F-140	-8.1	0.4	82.1	166.0	0.0	173.5	-215.5	0.0	223.0	2460.0
Camera + 2F-140/2F-140	-0.3	0.4	86.7	215.5	0.0	223.0	-215.5	0.0	223.0	2560.0
FT Sensor + Hand-E/Hand-E	-0.3	0.0	90.5	154.0	0.0	175.5	-154.0	0.0	175.5	2745.0
FT Sensor + Hand-E/2F-85	4.9	0.0	89.7	154.0	0.0	175.5	-166.0	0.0	187.5	2580.0
FT Sensor + Hand-E/2F-140	-2.5	0.0	94.3	154.0	0.0	175.5	-215.5	0.0	237.0	2680.0
FT Sensor + 2F-85/2F-85	-0.4	0.0	88.8	166.0	0.0	187.5	-166.0	0.0	187.5	2415.0
FT Sensor + 2F-85/2F-140	-8.0	0.0	93.7	166.0	0.0	187.5	-215.5	0.0	237.0	2515.0
FT Sensor + 2F-140/2F-140	-0.3	0.0	98.4	215.5	0.0	237.0	-215.5	0.0	237.0	2615.0
FT Sensor + Camera + Hand-E/Hand-E	-0.5	0.4	106.1	154.0	0.0	199.0	-154.0	0.0	199.0	2990.0
FT Sensor + Camera + Hand-E/2F-85	4.2	0.4	104.9	154.0	0.0	199.0	-166.0	0.0	211.0	2825.0
FT Sensor + Camera + Hand-E/2F-140	-2.5	0.4	109.4	154.0	0.0	199.0	-215.5	0.0	260.5	2925.0
FT Sensor + Camera + 2F-85/2F-85	-0.6	0.4	103.5	166.0	0.0	211.0	-166.0	0.0	211.0	2660.0
FT Sensor + Camera + 2F-85/2F-140	-7.6	0.4	108.4	166.0	0.0	211.0	-215.5	0.0	260.5	2760.0
FT Sensor + Camera + 2F-140/2F-140	-0.6	0.4	112.9	215.5	0.0	260.5	-215.5	0.0	260.5	2860.0



Info

The angle to calculate the TCP for Grippers mounted on a dual gripper assembly is as follows:

- Rx = 0
- Ry+/Ry- = 0.7854
- Rz = 0

The moment of inertia are calculated for a configuration where the fingers are fully open. Here is the approximate moment of inertia matrix for the Gripper:

2-FINGER 85 OPTION

$$I = \begin{bmatrix} I_{XX} & I_{XY} & I_{XZ} \\ I_{YX} & I_{YY} & I_{YZ} \\ I_{ZX} & I_{ZY} & I_{ZZ} \end{bmatrix} = \begin{bmatrix} 4180 & 0 & 0 \\ 0 & 5080 & 0 \\ 0 & 0 & 1250 \end{bmatrix} = \begin{bmatrix} 14.3 & 0 & 0 \\ 0 & 17.4 & 0 \\ 0 & 0 & 4.3 \end{bmatrix}$$

$kg * mm^2$ $lb * in^2$

2-FINGER 140 OPTION

$$I = \begin{bmatrix} I_{XX} & I_{XY} & I_{XZ} \\ I_{YX} & I_{YY} & I_{YZ} \\ I_{ZX} & I_{ZY} & I_{ZZ} \end{bmatrix} = \begin{bmatrix} 7400 & 0 & 0 \\ 0 & 9320 & 0 \\ 0 & 0 & 2260 \end{bmatrix} = \begin{bmatrix} 25.3 & 0 & 0 \\ 0 & 31.8 & 0 \\ 0 & 0 & 7.7 \end{bmatrix}$$

$kg * mm^2$ $lb * in^2$

Fig. 6-21: Robotiq 2-Finger inertia matrix.



6.2.4. Moment and force limits

The 2-Finger Adaptive Gripper has maximum moments and force limit. The listed moments and forces are independent to the force applied by the Gripper itself on it's payload. For payload calculation, refer to the **Mechanical specifications** section.

Warning

The following limits must be respected at all time. Calculation of maximum moment and force should include the robot acceleration and a safety factor.

Parameters	Finger Option	
	2-Finger 85	2-Finger 140
F_x, F_y, F_z	50 N	25 N
M_x^*	5 Nm	5 Nm
M_y^*	5 Nm	5 Nm
M_z	3 Nm	3 Nm

* Moments in x and y are calculated from the base of the fingertips as shown in figure 6-19.

Example usage of the listed limit :

- After picking it's normal payload, the robot can use the 2-Finger 85 Gripper to apply up to 50 N of force in any direction. Applying more then 50 N could damage the Gripper or result in payload loss.
- The Gripper can pick a screwdriver and apply 3 Nm of torque to screw (such moment would be in the Z axis).



6.3. Electrical specifications

SPECIFICATION	VALUE
Operating supply voltage	24 V DC \pm 10%
Absolute maximum supply voltage	28 V DC
Quiescent power (minimum power consumption)	< 1 W
Peak current	1 A



7. Maintenance

The Adaptive Gripper requires only external maintenance with limited downtime. Maintenance for both 2-Finger Adaptive Robot Grippers is required after specified usage, measured in time (normal 40h week) or in cycles (requesting an open and closed movement from the Gripper).

Following the maintenance interval will ensure :

- Correct functioning of your Gripper.
- Validity of your warranty.
- Proper lifetime for your Gripper.

Please visit support.robotiq.com for details on the maintenance operation.

Warning

Unless specified, any **repairs** done on the Gripper will be done by Robotiq.

Info

A cycle is defined as a **go to requested position** command that results in grasp force being applied (picking an object while opening or closing or closing the fingers on themselves).



Operation	Daily	Weekly	Semiannually (or 1 M cycles)	Annually (or 2 M cycles)
Gripper Cleaning	Dirty conditions	Normal conditions		
Periodic Inspection			X	
Finger Pad Replacement ¹			X	
Overhaul ²				X

Table 7-1: Maintenance intervals for the 2-Finger Grippers

¹Replace pads before if wear is visible.

²Overhaul is recommended after 2M cycles and is done by Robotiq at the user's expense, please contact Robotiq support.

Caution

Maintenance operations are for the average normal usage of the Gripper, the maintenance intervals must be adjusted according to environmental conditions such as:

- Operating temperature
- Humidity
- Presence of chemical(s)
- Presence of physical objects (debris, scraps, dust, grease etc.)
- Interaction with operated parts (sharp or rough)
- Dynamics of the operation (accelerations)

7.1. Gripper cleaning

Maintenance Interval	Tools You Need	Parts You Need
Weekly or daily in dirty operating conditions	<ul style="list-style-type: none"> • Flat head precision 2 mm screwdriver • 4 mm hex key • Dry tissue or towel • Medium strength thread locker 	None

Caution

The Robotiq 2-Finger Adaptive Robot Gripper is not waterproof or water resistant without additional protection, only clean the Gripper with a dry towel.

Info



Always turn off the robot and Gripper power supply before performing any maintenance operations on the Gripper.

Caution

Maintenance operator must be grounded to prevent electrostatic discharge that could damage the Gripper electronics.

1. Remove the Gripper from its coupling using the 4 mm hex key to unscrew the four (4) M5-0.8 x 25mm socket head cap screws. Note that each screw uses a tooth lock washer, do not lose them.
2. Use the flat head precision screwdriver to open or close the Gripper by accessing the transmission shaft under the Gripper, where the coupling connects. Illustrated in the figure below.
 - a. Open or close to access the palm pad and other parts of the Gripper.
3. Clean the Gripper with a dry towel, remove all debris, dirt and dust from the surface of the Gripper, clean all pads, dry thoroughly.
4. Clean the coupling with a dry towel, pay particular attention to the electrical contact.
5. Visually inspect the Gripper and pay attention to any visible damage.
6. Put the coupling back on and fix it with the four (4) M5-0.8 x 25mm socket head cap screws, use the tooth lock washers, apply medium strength thread locker to the M5 screws.

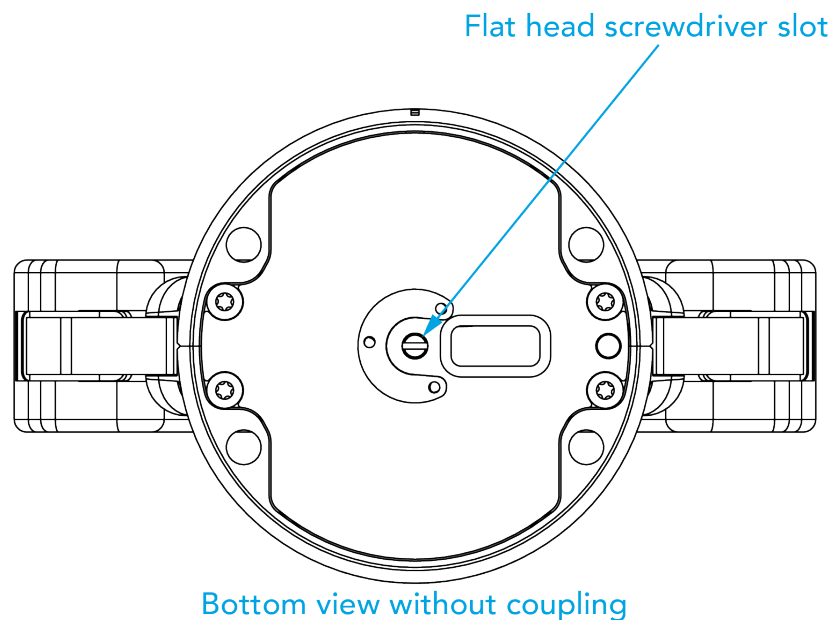

Fig. 7-1: Flat head screwdriver slot for manual opening and closing of the Gripper.



7.2. Periodic inspection

Maintenance Interval	Tools You Need	Parts You Need
Monthly	<ul style="list-style-type: none"> • Flat head precision 2 mm screwdriver • 4 mm hex key • Dry tissue or towel • Medium strength thread locker 	None (unless damage is detected)

Info

Always turn off robot and Gripper power supply before doing maintenance operations on the Gripper.

1. Remove and clean the Gripper following instructions in the **Gripper cleaning** section.
2. Inspect the Gripper :
 - a. Finger movement must be symmetric and fluid:
 - i. Test the return movement by pushing fingers open, the fingers must come back to the initial starting position on its own.
 - ii. Test the general movement of the fingers by actuation using the screwdriver insertion hole in the chassis.
 - b. Finger pad wear must not affect grasping, if wear is visible and affects movement, change fingerpad(s).
 - c. Check for any collision damage, if damage is visible, contact support@robotiq.com.
 - d. Check for any sign of wear on the Gripper chassis, if wear is present and may affect the Gripper, contact support@robotiq.com.
3. Put back in place respecting instructions from the **Gripper cleaning** section.



7.3. Fingertip replacement

Maintenance Interval	Tools You Need	Parts You Need
1 Million cycles or when wear is visible	<ul style="list-style-type: none">• Flat head 2 mm precision screwdriver• 4 mm hex key• Dry tissue or towel• low strength thread locker• medium strength thread locker	2 x Robotiq 2-Finger Adaptive Robot Gripper fingertip (silicone pad or V-grooved).

Refer to the **Spare Parts, Kits and Accessories** section section to order Robotiq 2-Finger Adaptive Robot Gripper replacement parts.

Info

Always turn off robot and Gripper power supply before doing maintenance operations on the Gripper.

1. Remove and clean the Gripper following instructions from the **Gripper cleaning** section.
2. Remove the worn fingertip by removing the M5 screws with the 4 mm hex key; make sure not to mislay the 2 mm indexing pins.
3. Clean the fingertip holder and dry thoroughly.
4. Insert the new fingertip by inserting the indexing pin in the fingertip holder.
5. Fix the fingertip using the provided M5-0.5 x 8 mm socket head cap screws, apply low strength threadlocker to the M5 screw threads.
6. Repeat for remaining finger.



7.4. Overhaul

Maintenance Interval	Tools You Need	Parts You Need
2 Million cycles or at warranty expiration	None	None

Gripper overhaul is necessary when the Gripper reaches 2 Million cycles or when warranty expires. Overhaul is done by Robotiq, please contact Robotiq support service.

Gripper overhaul includes, but is not limited to :

- Worn parts changed
 - Power transmission gearing mechanism
 - Plain bearings
 - Ball bearings
- Quality control
 - Specification test (force, speed, position)

Overhaul takes a maximum of 5 business days after reaching Robotiq, shipping is at customer's expense.

Tip

Loan units are available while your Gripper is under maintenance.



8. Spare Parts, Kits and Accessories

Spare parts, kits and accessories list:

Info

The following list is up to date at print time and is subject to change, check online for updates.

Info

Unless specified, screws, dowel pins and other hardware are included only for the Gripper side, never for the robot side.

Item	Description	Ordering Number (2-Finger 85)	Ordering Number (2-Finger 140)
Gripper basic unit	Adaptive Robot Gripper 2-Finger basic unit with fingers (no fingertips, no coupling)	AGC-GRP-2F85	AGC-GRP-2F140
Kit for OMRON TM	Gripper basic unit with silicone fingertips, 10 m cable and coupling for OMRON TM Series Robot	AGC-TM-KIT-85	AGC-TM-KIT-140
Controller	Optional controller for industrial communications see Robotiq Universal Controller Items	UNI-CTR-XXXX	
Finger Kit	Finger upgrade kit for 85 or 140 mm option. Included: <ul style="list-style-type: none"> • 2 x Replacement finger • 2 x Hardware kit • 1 x hex key 	AGC-FIN-KIT-85-V4	AGC-FIN-KIT-140-V4
Blank coupling	Blank coupling for Adaptive Robot Gripper 2-Finger, with screws for Gripper fixation and 1 m pigtail cable	AGC-CPL-BLANK-002	
ISO-9409-1-50-4-M6 coupling (coupling-to-wrist)	ISO 9409-1-50-4-M6 coupling for 2-Finger Robot Grippers, with screws for Gripper fixation	GRP-CPL-062	
ISO 9409-1-50-4-M6 coupling (coupling to controller)	ISO 9409-1-50-4-M6 coupling for 2-Finger Robot Grippers, with screws for Gripper fixation and 1 m pigtail cable	AGC-CPL-062-002	
ISO 9409-1-31.5-4-M5 coupling	ISO 9409-1-31.5-4-M5 coupling for Adaptive Robot Gripper 2-Finger, with screws for Gripper fixation and 1 m pigtail cable	AGC-CPL-063-002	
ISO 9409-1-40-4-M6 coupling	ISO 9409-1-40-4-M6 coupling for Adaptive Robot GripperGripper 2-Finger, with screws for Gripper fixation and 1 m pigtail cable	AGC-CPL-064-002	



Item	Description	Ordering Number (2-Finger 85)	Ordering Number (2-Finger 140)
56-8M4-1D4 coupling	Coupling for 56 mm PCD ¹ with (8) M4 and (1) 4mm indexing pin, with screws for 2-F Gripper fixation and 1 m pigtail cable	AGC-CPL-065-002	
56-6M4-1D6 coupling	Coupling for 56 mm PCD ¹ with (6) M4 and (1) 6mm indexing pin, with screws for 2-F Gripper fixation and 1 m pigtail cable	AGC-CPL-066-002	
60-4Ø5-1D5 coupling	Coupling for 60 mm PCD ¹ with (4) M5 thread and (1) 5mm indexing pin, with screws for 2-F Gripper fixation and 1 m pigtail cable	AGC-CPL-067-002	
63-6M6-2D6 coupling	Coupling for 63 mm PCD ¹ with (6) M6 and (2) 6mm indexing pins, with screws for 2-F Gripper fixation and 1 m pigtail cable	AGC-CPL-068-002	
40-4M5-1D3 coupling	Coupling for 40 mm PCD ¹ with (4) M5 and (1) 3mm indexing pins, with screws for 2-F Gripper fixation and 1 m pigtail cable	AGC-CPL-070-002	
31.5-4M4 coupling	Coupling for 31.5 mm PCD ¹ with (4) M4, with screws for 2-F Gripper fixation and 1 m pigtail cable	AGC-CPL-071-002	
Adapter plate to 63-4M6-71-2D3	Wrist adapter plate for use with AGC-CPL-064-002. Interface to 63 mm PCD ¹ with (4) M6 screws and 71 mm PCD ¹ with (2) M3 indexing pins	AGC-APL-151-002	
Adapter plate to 63-4M6-61_4-2D6	Wrist adapter plate for use with AGC-CPL-064-002. Interface to 63 mm PCD ¹ with (4) M6 screws and 61.4 mm PCD ¹ with (2) M6 indexing pins	AGC-APL-152-002	
Adapter plate to 80-6M8-2D82D8	Wrist adapter plate for use with AGC-CPL-064-002. Interface to 80 mm PCD ¹ with (6) M8 screws and (2) M8 indexing pins	AGC-APL-153-002	
2-Finger Device Cable (5M)	5 m Robotiq device cable for power and communication. Straight M12 5-pins female on one side, single ended on the other, shielded	CBL-COM-2065-05	
2-Finger Device Cable (10M)	10 m Robotiq device cable for power and communication. Straight M12 5-pins female on one side, single ended on the other, shielded	CBL-COM-2065-10	
RS232 to RS485 converter	Can be used to connect the RS232 adapter to the RS485 connector of the Robotiq Gripper	ACC-ADT-RS232-RS485	
USB to RS485 adapter	USB to RS485 adapter, can be used with device cable for USB connection	ACC-ADT-USB-RS485	
Silicone fingertip ²	Flat silicone fingertip for 2-Finger Adaptive Gripper, included: <ul style="list-style-type: none"> • one (1) silicone fingertip. • two (2) dowel pins (dia. 2 x 6 mm) 	AGC-TIP-204-085	AGC-TIP-420-140



Item	Description	Ordering Number (2-Finger 85)	Ordering Number (2-Finger 140)
	<ul style="list-style-type: none"> two (2) screws (M5-0.5 x 12 mm SHCS) 		
Grooved fingertip ²	Grooved aluminium fingertip for 2-Finger Adaptive Gripper, included: <ul style="list-style-type: none"> one (1) V-grooved fingertip two (2) screws M5-0.5 x 12 mm SHCS two (2) dowel pins dia. 2 x 6 mm 	AGC-TIP-205-085	AGC-TIP-421-140
Replacement finger	Replacement finger for 2-Finger Adaptive Gripper, included: <ul style="list-style-type: none"> One (1) finger Four (4) screws M3-0.5 X 8 LHCS One (1) proximal locking shaft One (1) link/bar locking shaft 	AGC-FIN-085	AGC-FIN-140
Finger Protector ²	Protector for 2-Finger Adaptive Gripper, included: <ul style="list-style-type: none"> One (1) protector Four (4) M3 screws 	AGC-PRO-KIT-V4	N/A
Parallel locking shaft ²	Parallel mechanism locking shaft for 2-Finger Adaptive Gripper, included : <ul style="list-style-type: none"> One (1) parallel locking shaft Two (2) M3 screws 	AGC-PARA-KIT	

¹Pitch Circle Diameter

²Part listed for two units, since two are required per Gripper.

Tip

For legacy part replacement visit the documentation archives and the appropriate manual or consult your Robotiq distributor.



9. Troubleshooting

Section contents coming soon.



10. Warranty and Patent

Robotiq warrants the 2F-85 and 2F-140 Adaptive Robot Grippers against defects in material and workmanship for a period of one year from the date of reception when utilized as intended. Robotiq also warrants that this equipment will meet applicable specifications under normal use.

Warning

Warranty applies under the following conditions:

- Usage respects the operating and storage conditions specified in Section 3.3
- Proper installation of the Gripper specified in Section 3 and the following subsections.
- Usage under normal one-shift operation (40h a week)
 - Or until a 2 000 000 cycle count¹ has been reached.
- Usage respects maintenance specified in Section 7.
- Usage respects recommended payload and force specified in the **Payload and force** section.

¹Cycle count: One (1) cycle is defined as an object picking attempt, successful or not (open or closing onto an object, or closing on itself). It is calculated in the internal memory of the 2-Finger Adaptive Gripper and can be seen with the Robotiq User Interface.

During the warranty period, Robotiq will repair or replace any defective 2-Finger Adaptive Robot Gripper, as well as verify and adjust the Gripper free of charge if the equipment should need to be repaired or if the original adjustment is erroneous. If the equipment is sent back for verification during the warranty period and found to meet all published specifications, Robotiq will charge standard verification fees.

The unit is considered defective when at least one of the following conditions occurs :

- The Gripper fingers cannot close or open;
- The Gripper feedback necessary for the robot program is not accessible.

Parts that come into contact with the work piece and wearing parts such as the finger and palm pads are not covered by the warranty.

Caution

The warranty will become null and void if the :

- Unit has been tampered with, repaired or worked on by unauthorized individuals.
- Warranty sticker has been removed.
- Screws, other than as explained in this guide, have been removed.
- Unit has been opened other than as explained in this guide.
- Unit serial number has been altered, erased, or removed.
- Unit has been misused, neglected, or damaged by accident.



This warranty is in lieu of all other warranties expressed, implied, or statutory, including, but not limited to, the implied warranties of merchantability and fitness for a particular purpose. In no event shall Robotiq be liable for special, incidental, or consequential damages.

Robotiq shall not be liable for damages resulting from the use of the Robotiq 2-Finger Adaptive Robot Gripper, nor shall Robotiq be responsible for any failure in the performance of other items to which the 2-Finger Adaptive Robot Gripper is connected or the operation of any system of which the Gripper may be a part.



Exclusions

This warranty excludes failure resulting from: improper use or installation, normal wear and tear, accident, abuse, neglect, fire, water, lightning or other acts of nature, causes external to the Gripper or other factors beyond Robotiq's control.

Robotiq reserves the right to make changes in the design or construction of any of its products at any time without incurring any obligation to make any changes whatsoever on units already purchased.

Patent

This product incorporates technology developed by Lionel Birglen, professor at Polytechnique Montreal, and is used under license of Polyvalor LP.



11. Contact

www.robotiq.com

Contact Us

Phone

1-888-ROBOTIQ (762-6847)
(01) 418-380-2788 Outside US and Canada

Fax

1-418-800-0046

Technical support and engineering

option 3

Sales

option 2

Head office

Robotiq:
966, chemin Olivier
Suite 500
St-Nicolas, Québec
G7A 2N1
Canada



Where automation Pros come to share their know-how and get answers.

dof.robotiq.com



12.2. Applied standards

This section describes all applied harmonized standards for the design and production of the Robotiq 2-Finger Adaptive Gripper. Standards are applied where applicable, some points may not be applied if not applicable to this specific product. Conformity is not enforced by any laws, it is self-applied and the aim is to define normal safety and performance requirements for similar products.

Caution

Conformity of the product is only met if all instructions of the following manual are followed. Among others; installation, safety measure and normal usage must be respected.

The following standards have been applied:

NF EN ISO 14539	2000	Manipulating industrial robots — Object handling with grasp-type grippers — Vocabulary and presentation of characteristics
NF EN ISO 12100	2010	Safety of machinery — General principles for design — Risk assessment and risk reduction
NF EN IEC 60204-1	2006	Safety of machinery — Electrical equipment of machines — Part 1: General requirements

