



Original Notice

© 2019. Robotiq, Inc.

**Robotiq Wrist Camera  
for Universal Robots**

**Instruction Manual**

<b>1. Table of Contents</b>	<b>3</b>
<b>2. Revisions</b>	<b>5</b>
<b>3. General Presentation</b>	<b>8</b>
3.1. Vision System Components	8
<b>4. Safety</b>	<b>12</b>
4.1. Warning	12
4.2. Intended Use	14
<b>5. Installation</b>	<b>15</b>
5.1. Scope of Delivery: Wrist Camera Kits for Universal Robots	16
5.2. Required Tools and Equipment	17
5.3. Environmental and Operating Conditions	18
5.4. Mechanical Installation	19
5.5. Electrical Setup	21
5.6. Software	23
<b>6. Snapshot Position</b>	<b>29</b>
6.1. Launching the Calibration and Snapshot Position Wizard	29
6.2. Choosing a Calibration Method	29
6.3. Saving the Snapshot Position	33
<b>7. Object Teaching</b>	<b>35</b>
7.1. Guidelines on Object Teaching	35
7.2. Teach Object Wizard	37
<b>8. Cam Locate Node</b>	<b>94</b>
8.1. Programming a Cam Locate Loop	95
8.2. Linear Move with Feature	96
8.3. object_location pose	97
8.4. Edit Detection Threshold and Object Location	100
8.5. Using a Variable Snapshot Position	103
8.6. Auto Pick	105
8.7. Camera Locate Settings	106
<b>9. Scan Code Node</b>	<b>108</b>
9.1. Supported Types of Codes	108
9.2. Guidelines on Reading Codes	109



9.3. Using the Scan Code Node .....	109
9.4. Strings Data Stored in CSV files .....	110
<b>10. Find Visual Offset and Apply Visual Offset Nodes, and Defining Tags .....</b>	<b>111</b>
10.1. Defining a Tag .....	111
10.2. Using a Tag in a Robot Program .....	112
10.3. Find Visual Offset Node .....	114
10.4. Apply Visual Offset Node .....	115
<b>11. Save Image Node .....</b>	<b>116</b>
<b>12. Specifications .....</b>	<b>118</b>
12.1. Mechanical Specifications of Wrist Camera .....	119
12.2. Electrical and Optical Specifications of the Wrist Camera .....	121
12.3. Vision System Specifications .....	122
<b>13. Maintenance of the Wrist Camera .....</b>	<b>127</b>
<b>14. Spare Parts, Kits and Accessories .....</b>	<b>128</b>
<b>15. Troubleshooting .....</b>	<b>129</b>
<b>16. Wrist Camera Warranty and Patent .....</b>	<b>130</b>
<b>17. Wrist Camera Harmonized Standards, Declarations and Certificates .....</b>	<b>EB</b>
17.1. Declaration of Incorporation .....	EB
17.2. Ingress Protection Certificate .....	EC
<b>18. Contact .....</b>	<b>ED</b>



---

## 2. Revisions

---

Robotiq may modify this product without notice, when necessary, due to product improvements, modifications or changes in specifications. If such modification is made, the manual will also be revised, see revision information. See the latest version of this manual online at: [robotiq.com/support](http://robotiq.com/support).

### 2019-10-29

- Modified appearance of text boxes.
- Added dynamic cross-references to sections of the Instruction Manual.
- Section " Required Tools and Equipment"
  - Modified electrical ratings shown in Table 1-1: Robotiq Wrist Camera and gripper power supply requirements
  - Updated recommended optional equipment
- Subsection " Snapshot Position" :
  - Rewrote subsection with a more detailed workflow
  - Added screenshots and printing specifications for the calibration board
- Section " Cam Locate Node" :
  - Renamed subsection " Settings" to " Camera Locate Settings"
  - Added typical use tips for options under the " Camera Locate Settings" window
  - Added " Autopick" subsection
- Section " Scan Code Node" :
  - Added subsection " Guidelines on Reading Codes"
  - Added subsection " Strings Data Stored in CSV files"
- Section " Intended Use" : since barcodes and 2D codes is now supported by the Wrist Camera, URCap, removed a sentence that mentioned it was not.
- Section " Object Teaching" : removed all mentions of the play button and question mark button which were used to access contextual help contents. This contextual help has since been removed from the Wrist Camera URCap.

### 2019-10-24

- Fixed numbering error in Table of Contents.
- Streamlined instructions in many instances, with lighter formatting.

### 2019-10-17

- Renamed section " Programming with the Camera Locate Node" to " Cam Locate Node" .
- Added sections:
  - Save Image Node
  - Scan Code Node
  - Find Visual Offset and Apply Visual Offset Nodes, and Defining Tags



- Added subsections:
  - In "Cam Locate Node"
    - Programming a Cam Locate Loop
    - Settings
  - In "Snapshot Position"
    - Choose Calibration Method
- Added two SKU to section "Spare Parts, Kits and Accessories"
  - ACC-TAG-1BAG5
  - ACC-TAG-5BAG5 (partners only)

#### **2019-05-08**

Updated section 5. Gripper Clearance Validation feature added.

#### **2019-03-07**

Updated section 5 and all pertaining subsections; major changes to the Camera settings. Align-to-axis and Align over features added.

#### **2018-09-10**

Updated section 3, 5 and 6 according to the PolyScope version of the user (CB-Series vs. e-Series).

Updated section 5 and all pertaining subsections; major changes to the Teach object wizard (color validation layer masks, multiple object detection, e-Series support).

#### **2018-05-01**

Updated section 5 and all pertaining subsections; major changes to the Teach object wizard

#### **2018-03-26**

Updated Section 3.6.2 for Update and uninstall

#### **2017-06-07**

Updated Section 3.6 for URcap package installation procedure

Updated Section 4.2 for calibration process

Updated Sections 5.2, 5.2.1, 5.2.2, 5.2.3 for new and improved teaching methods.

Added Section 6.2 to use advanced programming with the vision system.

Updated technical specifications (Section 7.3).

Updated calibration board for UR5 and UR10 robots (Section 4)

#### **2016-11-16**



Updated specifications (section 6)

Updated installations instructions (section 4)

Added Troubleshooting instructions (section 9.1)

**2016-08-26**

First release



## 3. General Presentation

The terms "Camera" and "Wrist Camera" used in the following manual all refer to the Robotiq Wrist Camera, while the terms "Vision" and "Vision System" used in the following manual all refer to the Robotiq Wrist Camera Vision System for Universal Robots.

The Vision System uses the Robotiq Wrist Camera and the Cam Locate software on Universal Robots to provide you with a simple object teaching interface.

The interface allows to set up the Vision System so it can recognize object locations and orientations automatically. It locates one object at a time on a predefined workplane, gets the object position (x, y) and orientation along the z-axis, and allows to operate the robot according to the object location. The Wrist Camera is designed for industrial applications in combination with Robotiq adaptive grippers.

### Info

This manual uses the metric system. Unless otherwise specified, **all dimensions are in millimeters.**

### Caution

The following section presents the key features of the product, and must not be considered as appropriate to its operation. Product features are detailed in relevant sections of the Instruction Manual.

Read and understand safety guidelines before attempting to use your product.

## 3.1 Vision System Components

**Fig. 3-1** below describes the various components of the Robotiq Vision System for Universal Robots. This system will use the Robotiq Wrist Camera, used with any of these mentioned Universal Robots versions (UR3, UR5, UR10). The system is compatible with the CB3.1 controller or later, as well as with any e-Series releases. For a list of provided components with your Robotiq Wrist Camera kit for Universal Robots, see section **Scope of Delivery: Wrist Camera Kits for Universal Robots** on page 16.

### Caution

The Robotiq Vision System is only compatible with Universal Robots with a robot controller version CB3.1 or later, as well as with any e-Series releases. To identify your robot controller, contact your Universal Robots representative.

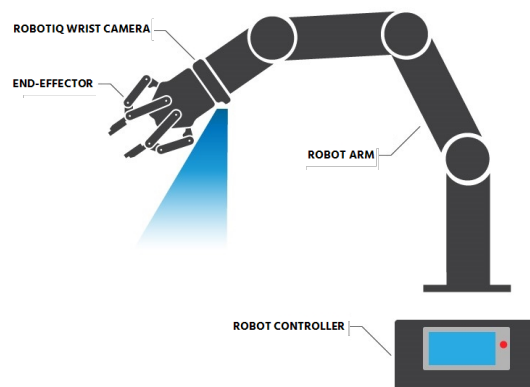

*Fig. 3-1: Schematic representation of the Robotiq Wrist Camera Vision System hardware.*



### And Now, Some Terminology

**Robotiq Wrist Camera**

Automatic 5 Mpx camera fitted with LED and made for collaborative robots, either independently or with an end-effector.

**end-effector**

Tool incorporated to a robot arm via its tool flange.

**robot arm**

Any collaborative robot.

**robot controller**

Computer that controls the robot, its end-effector and/or third party devices.

## 3.1.1. Snapshot Position and Workspace

**Fig. 3-1** illustrates the various terms used in the following manual to describe the Vision System's Snapshot Position and workspace. The object location process will always start at the snapshot position, that position will determine the field of view of the Wrist Camera i.e. the workspace. See section **Snapshot Position** on page 29 for details on how to teach the snapshot position.

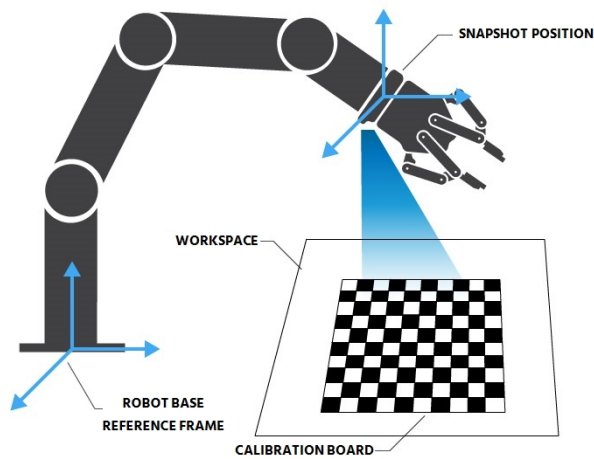

*Fig. 3-2: Schematic representation of the Robotiq Vision System snapshot position and work plane concepts.*

### And Now, Some Terminology

**snapshot position**

Robot pose used to take snapshots with the Wrist Camera.

**work plane**

Area of interest for the Vision System. Fits the field of view of the Wrist Camera.

**object**

Object to locate using the Vision System.

**calibration board**

Grid provided with the Wrist Camera. Used in the calibration process of the snapshot position.

*Table 3-1: Terminology of the Vision System.*



### 3.12. Object Location

To locate objects, the Vision System uses the Cam Locate node detailed in section **Cam Locate Node** on page 94. **Fig. 3-3** summarizes this process.

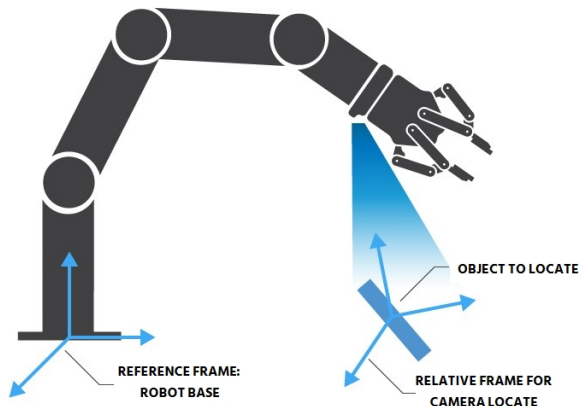

*Fig. 3-3: Schematic representation of the object location process.*

#### And Now, Some Terminology

<b>object to locate</b>	Object to locate using coordinates x, y, and Rz (rotation).
<b>camera locate relative frame</b>	Reference frame, as updated by the Vision System, used to locate an object.
<b>robot base reference frame</b>	Frame coordinates defined as [0, 0, 0].

*Table 3-2: Terminology of the object location process.*

### 3.13. Wrist Camera

The hardware at the heart of the Vision System is the Robotiq Wrist Camera illustrated in the . For installation instructions, section **Wrist Camera** on page 10.



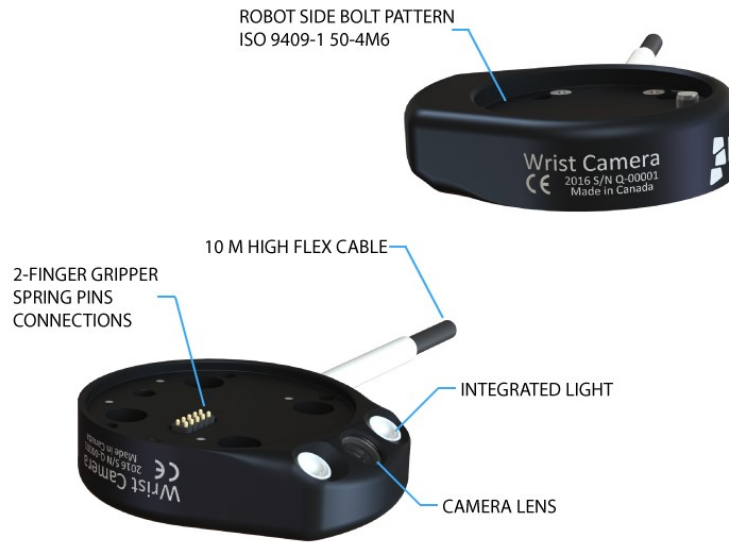

Fig. 3-4: Main features of the Wrist Camera.

Hardware	Specifications
CMOS image sensor with liquid lens	<ul style="list-style-type: none"> <li>Resolution: 0.3 to 5 Mpx</li> <li>Frame rate: 2 to 30 FPS</li> <li>Focus: 70mm to <math>\infty</math></li> </ul>
6 LED	<ul style="list-style-type: none"> <li>Diffuse white light</li> <li>Automatic control</li> </ul>
10-m high flex cable	<ul style="list-style-type: none"> <li>USB 2.0</li> <li>24V DC power</li> </ul>
tool flange: ISO 9409-1:2004 4 X M6 $\varnothing$ 50mm bolt pattern	<ul style="list-style-type: none"> <li>Wrist Camera is mounted on the tool flange</li> <li>Grippers are mounted on the Wrist Camera</li> </ul>

Table 3-3: Some hardware specifications of the Wrist Camera.

### Info

The Robotiq Wrist Camera provides a direct mounting interface for grippers, including a mechanical interface, 24V power and gripper/robot communication capabilities.

---

## 4. Safety

---

### Warning

Operators must read and understand all instructions contained in this manual prior to operating the Wrist Camera.

### Info

Operators are responsible for the following operations on the device: installation, control, maintenance, inspection, calibration, programming, decommissioning.

This Instruction Manual presents components of the Vision System, and general operations regarding the whole life-cycle of the product through installation, operation, and decommissioning.

Drawings and photos in this Instruction Manual are typical examples, and the actual product may differ.

### 4.1 Warning

#### Caution

Please comply with warnings contained in current document. Any other uses are inappropriate and may cause injury or damage.

#### Warning

The Wrist Camera Vision System used in human-robot collaboration must not be considered a complete safety measure, additional dedicated safety device(s) must be considered. Vision System failure can occur and result in danger for workers or machinery if not properly secured. See local or international safety measure for human-robot collaboration.



### **Warning**

- Secured the Wrist Camera before operating the robot.
- Do not install or operate a Wrist Camera that is damaged or lacking parts.
- Only supply direct current to the Wrist Camera.
- Make sure all cords are secured at both the Wrist Camera and the robot levels.
- Always respect the recommended keying for electrical connections.
- Before running a program, make sure that neither obstacles nor people are in the robot path.
- All local safety measures and/or laws on robot operation must be applied to the Vision System.
- Avoid looking straight at the LED when they are turned on, as this may cause dazzlement.
- Any use of the Vision System in noncompliance with these warnings is inappropriate and may cause injury or damage.



## 4.2. Intended Use

The Vision System is designed to locate objects laying flat on the defined workspace. The system can identify and locate multiple kind of objects, each object will require its own object teaching process as explained in section **Object Teaching** on page 35. The Vision System gets the object's position (x, y) and orientation along the z axis. It allows to operate the robot according to the object location.

### Tip

section **Guidelines on Snapshot Position** on page 34 will give you advice on what workspace should be used or avoided. section **Object Teaching** on page 35 will give you advice on what objects can be located or not, including recommendations on using backgrounds.

### Caution

The Vision System is not intended for metrology applications.

### Note

Always comply with local and/or national laws, regulations and directives on automation safety and general machine safety.

The unit may be used only within the range of its technical specifications. Any other use of the product is deemed improper and unintended use. Robotiq will not be liable for any damages resulting from any improper or unintended use.



---

# 5. Installation

---

This section covers the following topics.

- To verify your Wrist Camera package, see section **Scope of Delivery: Wrist Camera Kits for Universal Robots** on page 16.
- For a list of required hardware for your Wrist Camera, see section **Required Tools and Equipment** on page 17.
- Details on the operating range of the Wrist Camera can be found in section **Environmental and Operating Conditions** on page 18.
- To find out how to mount your Wrist Camera on your robot, see section **Mechanical Installation** on page 19. It also includes information on coupling it with another end-effector.
- Details on electrical wiring and specifications, as well as tips on cable management, are provided in section **Electrical Setup** on page 21.
- To install your Wrist Camera software, see section **Software** on page 23.

## Warning

Before installing :

- Read and understand the safety instructions related to the Vision System.
- Verify your package according to the scope of delivery and your order.
- Have the required parts, equipment and tools listed in the requirements ready.

## Warning

When installing :

- Meet the environmental conditions.
- Do not operate the Vision System, or even turn on the power supply, before the Wrist Camera is **firmly secured, and the danger zone is cleared.**



## 5.1. Scope of Delivery: Wrist Camera Kits for Universal Robots

### 5.1.1 RWC-UR-KIT

Includes the Wrist Camera and required hardware.

- Robotiq Wrist Camera with 10-m high flex cable `RWC-CAM-001`
- Universal Robots pattern tool plate `RWC-TOOL-062`
- 16 Gb USB stick `ACC-USB-16G`
- USB software license dongle `ACC-USB-DONGLE`
- 4-port USB hub `ACC-USB-4-HUB`
- Calibration board `ACC-CALIB-BOARD`
- Colored background for object teaching `ACC-TEACH-BACK`
- Hardware kit to mount the Wrist Camera to Universal Robots.

### 5.1.2. CUR-AGC-085-RWC or CUR-AGC-140-RWC

Includes a 2-Finger Adaptive Robot Gripper and a Wrist Camera.

- Wrist Camera Kit for Universal Robots includes:
  - Robotiq Wrist Camera with 10-m high flex cable `RWC-CAM-001`
  - 16 Gb USB stick `ACC-USB-16G`
  - USB software license dongle `ACC-USB-DONGLE`
  - 4-port USB hub `ACC-USB-4-HUB`
  - Calibration board `ACC-CALIB-BOARD`
  - Colored background for object teaching `ACC-TEACH-BACK`
  - Hardware to mount the Wrist Camera to robots.
- Gripper parts:
  - Basic Gripper unit (85 or 140) `AGC-GRP-002` or `-140` (depending on selected combo)
  - Screws to mount gripper on Wrist Camera.



## 5.2. Required Tools and Equipment

The following tools are required to install the Wrist Camera:

- 2 mm slotted screwdriver to perform terminal block connections when wiring.

Provided tools with the Wrist Camera:

- 4 mm hex key to mount the Wrist Camera on a Universal Robots model.

Optional tools if installing with **CUR-AGC-085-RWC** or **CUR-AGC-140-RWC**:

- None. Use the provided 4 mm hex key.

The following parts are required for setup:

- A Universal Robots UR3, UR5 or UR10 model, along with its controller

### Warning

Only compatible with controller version CB3.1 and later.

- Universal Robots PolyScope version must be 3.9 or later in order to install the URCap.
- Power supply if not using a Universal Robots controller supply (see below);
- Fuse, see information below.

The Wrist Camera needs to be supplied by a DC voltage source. This power supply is not included with the Wrist Camera Kit for Universal Robots. Required power supply must match the Robotiq device. The following table shows the specifications with regards to the power supply required to operate the Wrist Camera and the optional Robotiq gripper.

SPECIFICATION	VALUE
Output voltage	24 V DC $\pm$ 10%
Output current	2 A
Overcurrent	Recommended power supply with internal protection, otherwise fusing is required. 4 A fuse at 25°C [77°F] <sup>1</sup>

Table 5-1: Robotiq Wrist Camera and gripper power supply requirements.

### Info

<sup>1</sup>Suggested fuse is a: Phoenix Contact # 0916606, 4A Thermal Breaker. Use AWG #20 wiring.

### Warning

If your power supply exceeds the specified regulation, over-voltage protection is required.

Robotiq recommends using this power supply:

- For the 2A output current: TDK-Lambda DPP Series, 50W Single Output DIN Rail Mount Power Supply. **DPP50-24**.





## 5.3. Environmental and Operating Conditions

The Wrist Camera is designed for industrial applications. Always respect the following specified operating environmental conditions:

CONDITION	VALUE
Minimum storage	-30°C [-22°F]
Maximum storage	70°C [158°F]
Minimum operating temperature	0°C [32°F]
Maximum operating temperature	50°C [122°F]
Humidity (non-condensing)	Non-condensing.
IP Rating	IP67
Others	Lenses must be free from dust, soot and water. Environment must be free from powerful electromagnetic interference. Environment must be free from corrosive or explosive liquids or gases.

*Table 5-2: Environmental and operating conditions for the Wrist Camera.*

## 5.4. Mechanical Installation

### 5.4.1 Mounting the Wrist Camera With a End-Effector on Universal Robots

#### Info

To mount the Wrist Camera with either an adaptive gripper, see section **Mounting the Wrist Camera With a Gripper on Universal Robots** on page 20.

1. Place the Wrist Camera (RWC-CAM-001) on the robot arm. Align the Wrist Camera dowel pin with tool flange.
2. Place tool plate (RWC-TOOL-062) on Wrist Camera. Align the tool plate dowel pin with Wrist Camera.
3. Mount end-effector on robot arm, using M6 screws that pass through the tool plate and the Wrist Camera.
4. Attach cable along robot arm. For details, see section **Cable Management** on page 23.

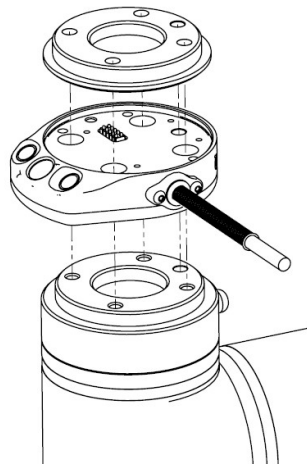

Fig. 5-1: Mounting the Wrist Camera kit on Universal Robots.

#### Info

The end-effector is secured directly in the tool flange of the robot arm. Both the Wrist Camera and the tool plate are fitted with clearance holes for this assembly.

M6 screws to mount an end-effector on the Wrist Camera are not provided. Use M6 screws of appropriate length to secure end-effector on robot arm.

#### Caution

When mounting only a Wrist Camera on a robot, the spring pins used to connect to grippers are exposed. Handle them carefully.



### Warning

Wrist Camera must be oriented properly.

Do not offset the Wrist Camera from the tool center point **on the X and Y axes**, or **around the Z axis**.

## 5.4.2. Mounting the Wrist Camera With a Gripper on Universal Robots

To mount a Wrist Camera and a Robotiq adaptive gripper on a Universal Robots machine, follow these instructions, and refer to the figure below:

1. Place the Wrist Camera (RWC-CAM-001) on the robot arm. Align the Wrist Camera dowel pin with tool flange.
2. Mount Wrist Camera on tool flange using the provided screws and lock washers.
3. Mount gripper on the Wrist Camera using the provided screws and lock washers.
4. Attach cable along robot arm. For details, see section **Cable Management** on page 23.

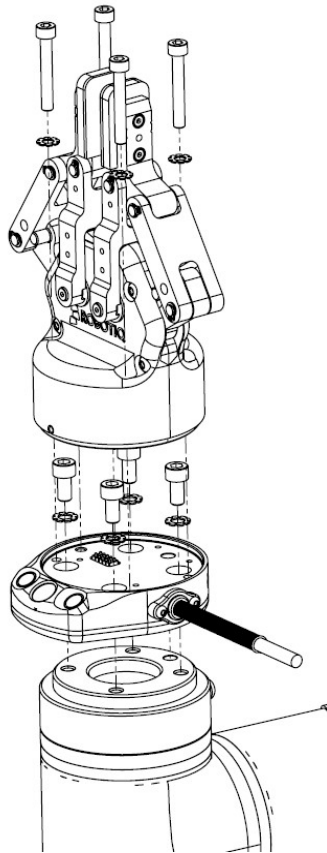
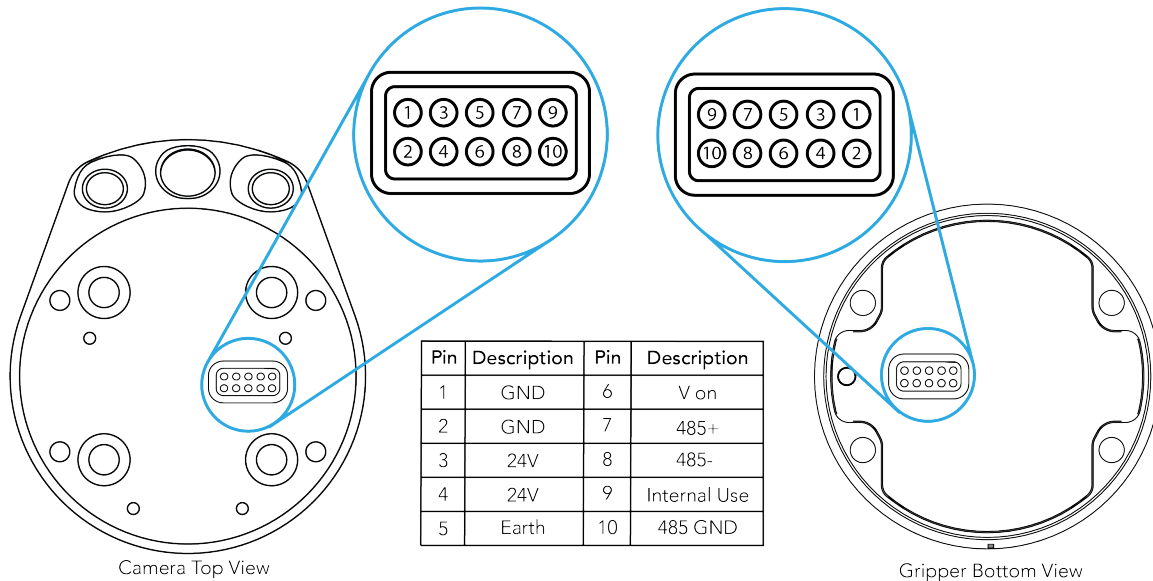

Fig. 5-2: Mounting both a Wrist Camera and a 2-Finger Adaptive Robot Gripper on a Universal Robots robot.

## 5.5. Electrical Setup

### 5.5.1 Pinout Interface

The Wrist Camera interfaces with an end-effector (e.g. a Robotiq adaptive gripper) via a 10-pin connector located on its outer surface.



### 5.5.2. Power Supply

#### Caution

If mounting a 2-Finger Adaptive Robot Gripper on the Wrist Camera, the latter acts as a gripper coupling. Therefore, only the Wrist Camera device cable is required to provide power and communication to both itself and the gripper. Wiring setups are identical whether you use the Wrist Camera alone, or with an end-effector.

Power and communication are established with the Wrist Camera via the 10-m high flex cable. It provides 24V power supply to the Wrist Camera and enables USB 2.0 communication with the Universal Robots controller.

Follow these instructions to wire into the Universal Robots controller :

1. Turn off the robot controller.
2. Connect the 10-m high flex cable to the robot controller. Use any available 24V and 0V slots. See **Fig. 5-3**
  - Connect the red wire (24V).
  - Connect the black wire (0V).

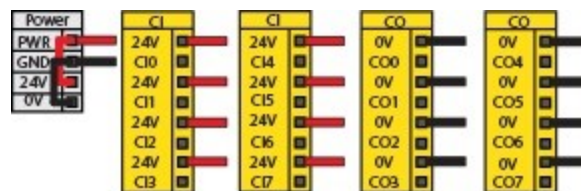
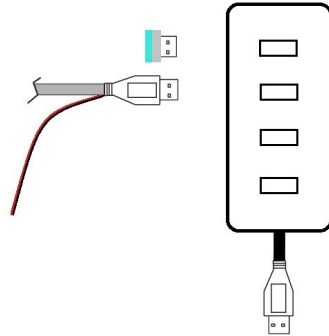

Fig. 5-3: Power supply wiring on CB3.1 Universal Robots controller.



3. Connect the 4-port USB hub (ACC-USB-4-HUB) to the robot controller.
4. Connect the Wrist Camera USB cable to the 4-port USB hub.
5. Connect the USB license dongle (ACC-USB-DONGLE) to the 4-port USB hub.



*Fig. 5-4: Connecting to the 4-port USB hub.*

**Tip**

Wrist Camera grounding is optional and is done via the robot ground. The Wrist Camera dowel pin acts as ground connector.

## 5.5.3. Cable Management

### Warning

Use proper cabling management. Remember to leave enough mobile cable to allow for robot movement along all axes without pulling out connectors. Always protect the controller side of the cable connection with a strain relief cable clamp.

## 5.6. Software

Make sure the Wrist Camera is properly mounted on the robot arm and that all electrical wiring is correctly done (see section **Mechanical Installation** on page 19 and section **Electrical Setup** on page 21). Make sure your Universal Robots software is up-to-date. PolyScope must be version 3.9 or later in order to install a URCap.

- For details on installing software, see section **Installation** on page 15.
- To update or uninstall software, see section **Update and Uninstall** on page 27.

### Warning

Do not disconnect the 16 Gb USB stick or the USB license dongle from the robot controller, even after the installation has been completed.

### Tip

Before using your Universal Robots, adjust the center of mass and payload from the Installation tab. For details, see section **Mechanical Specifications of Wrist Camera** on page 119.



## 5.6.1 Installing the Wrist Camera URCap

Make sure the Wrist Camera is properly mounted to the robot arm and that all electrical wiring is correctly done (see section **Mechanical Installation** on page 19 and section **Electrical Setup** on page 21). Make sure your Universal Robots software is up-to-date. The Wrist Camera URCap is compatible with PolyScope 3.9 and later versions.

### Tip

For details on updating your URCap, see section **Update and Uninstall** on page 27.

1. Go to [robotiq.com/support](http://robotiq.com/support).
2. Click Select Product > Wrist Camera > Universal Robots > Software > Wrist Camera Software > DOWNLOAD ZIP. This downloads the latest UCC-X.X.X compressed file.
3. Decompress the content of the latest UCC-X.X.X compressed file on the provided 16 Gb USB stick (ACC-USB-16G).
4. Place the.urcap file and the Vision System folder on the root of the USB drive, as shown in Fig. 5-5.



Fig. 5-5: Save these files at the root of the 16 Gb USB stick.

- With the robot controller ON, connect the 16 Gb USB stick containing the latest URCap and Vision System to the 4-port USB hub.

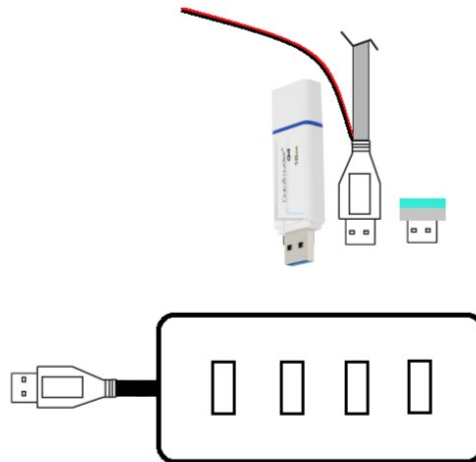







Fig. 5-6: Connecting to the 4-port USB hub.

## For CB-Series: PolyScope 3.9 and later

1. Tap **Setup Robot** > **URCaps Setup** > , and select `Robotiq_Wrist_Camera-X.X.X.urcap` from the USB stick.
2. Tap , and wait for PolyScope to reboot.
3. Tap **Program Robot** > **Installation** > **Camera** > **Dashboard** tab.
4. Check status of the Vision System.

## For e-Series: PolyScope 5.3 and later

1. Tap  > **Settings** > **System** > **URCaps** > , and select `Robotiq_Wrist_Camera-X.X.X.urcap` from the USB stick.
2. Tap , and wait for PolyScope to reboot.
3. Tap **Installation** > **URCaps** > **Camera** > **Dashboard**.
4. Check status of the Vision System.

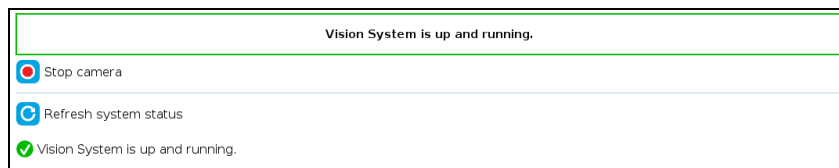

Fig. 5-7: The Camera dashboard indicates the Vision System has been correctly installed.

1. Tap **Install**. The Vision System installation starts.
2. If the firmware has to be updated, tap **Upgrade Camera firmware**. For details, see section **Update and Uninstall** on page 27.

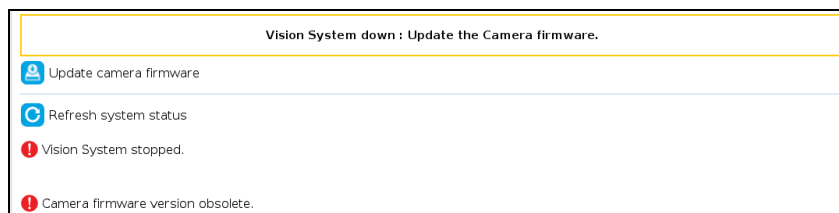

Fig. 5-8: The Camera tab indicates you must update the Wrist Camera firmware.

1. Wait for the Vision System to start.
2. The installation is completed.
3. In order to use another USB drive on the controller, reboot the robot controller.

### Warning

Do not disconnect the 16 Gb USB stick or the USB license dongle from the robot controller, even after the installation has been completed.

### Tip

The Dashboard tab contains helpful information for troubleshooting the Vision System.





## Testing the Installation

After the installation has been completed, follow these instructions to check that the Vision System works as expected.

### For CB-Series: PolyScope 3.9 and later

1. From a robot program, go to Installation tab > Camera> Dashboard.
2. Check system status. Make sure the Vision System is running.
3. Go to the Camera tab. The output image will appear.

### For e-Series: PolyScope 5.3 and later

1. Tap Installation> URCaps > Camera > Dashboard.
2. Check the system status. Make sure the Vision System is running.
3. Go to the Camera tab. The output image will display.

#### Tip

Before using your Universal Robots, adjust the center of mass and payload from the Installation tab. For details, see section **Mechanical Specifications of Wrist Camera** on page 119.





## 5.6.2. Update and Uninstall

### Warning



Updating the Wrist Camera software, unplugging the USB storage device and/or switching USB ports must **always** be done while the robot is initialized and running.

### Version 11 and later

#### For CB-Series: PolyScope 3.9 and later

1. From a robot program, go to the Installation tab > Camera > Dashboard > Stop camera > Uninstall.
2. Remove the 16 Gb USB stick containing the URCap and Vision Server from the 4-port USB hub.
3. Tap **Setup Robot**> **URCaps Setup**.
4. In the Active URCaps text box, select the Camera URCap.
5. The Camera URCap is highlighted.
6. Tap  to uninstall the URCap.
7. Tap  to complete the uninstall process. The robot controller reboots.
8. Connect to a PC the 16 Gb USB stick containing the URCap and Vision Server.
9. Format USB stick in FAT32 format.
10. See section **Installation** on page 15 to install the latest software.



#### For e-Series: PolyScope 5.3 and later

1. Tap the **Installation** tab > **URCaps** > **Camera** > **Dashboard** > **Stop camera** > **Uninstall**.
2. Remove the 16 Gb USB stick.
3. Tap  > **Settings System** > **URCaps**.
4. In the Active URCaps textbox, select the Camera URCap.
5. The Camera URCap is highlighted.
6. Tap  to uninstall the URCap.
7. Tap  to complete the uninstall process. The robot controller reboots.
8. Connect to a PC the 16 Gb USB stick containing the URCap and Vision Server.
9. Format USB stick in FAT32 format.
10. See section **Installation** on page 15 to install the latest software.

### Version 10.2 and earlier

1. Copy the following file :`urmagic_uninstall.sh` to a blank USB stick.
2. From a robot program, go to the Installation tab > Camera > Camera > Stop Camera.
3. With the controller on, insert the USB stick containing the `urmagic` file into the Teach Pendant. The uninstallation procedure starts automatically.



4. Once uninstallation is complete, remove the USB stick containing the `urmagic` file.
5. Remove the 16 Gb USB stick containing the Vision Server.
6. Go to **Setup Robot > URCaps Setup**.
7. In the Active URCaps text box, tap the Camera URCap.
8. The Camera URCap is highlighted.
9. Tap  to uninstall the URCap.
10. Tap  to complete the uninstall process. The robot controller reboots.
11. Connect to a PC the 16 Gb USB stick containing the URCap and Vision Server.
12. Format USB stick in FAT32 format.
13. See section **Installation** on page **15** to install the latest software.



# 6. Snapshot Position

Prior to teaching objects with the Cam Locate URcap node (see section **Cam Locate Node** on page 94), the operator must define a snapshot position using the Snapshot Position wizard. For more details on the concepts of snapshot position, work plane, and calibration board, see **Table 3-1: Terminology of the Vision System.** on page 9

## 6.1 Launching the Calibration and Snapshot Position Wizard

Go to the Installation tab > URcaps > Camera > Snapshot, select a feature point from the dropdown list, and tap .

To create a feature point, follow these instructions:

1. Go to the Installation tab > Features > Point.
2. Select the created point from the features in the list.
3. CB-Series models only: check the Variable box.
4. Tap Set point > OK.

**Tip**  
The position of this feature point is not critical; your robot can be repositioned in later stages of the calibration and snapshot position process.

5. Tap Rename to give a meaningful name to your feature point.
6. Save the Installation file.

This feature point will be assigned as a reference for the snapshot position process. After completing the calibration process, this feature point is removed from the dropdown list, and cannot be reused to create another snapshot position.

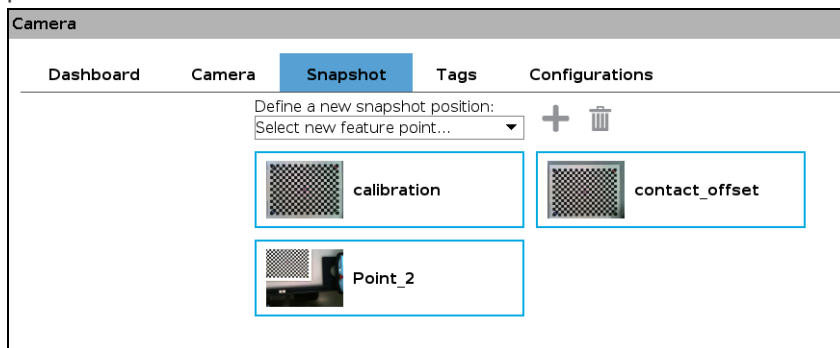

Fig. 6-1: From the Snapshot tab, select a new feature point from the dropdown list

**Tip**  
You can select a thumbnail displayed in a blue rectangle, as shown in **Fig. 6-1**. During the snapshot position process, you will be offered to move to the snapshot position linked to this thumbnail .

## 6.2. Choosing a Calibration Method

When calibrating, three calibration methods are available.



Calibration Method	Definition	Purpose
New Snapshot Position	Using existing camera calibration and work plane.	For objects on the same work plane.
New Work Plane & Position	Using existing camera calibration.	For objects on a different work plane.
Full Calibration	New camera calibration, work plane and position.	Before first use of the camera.

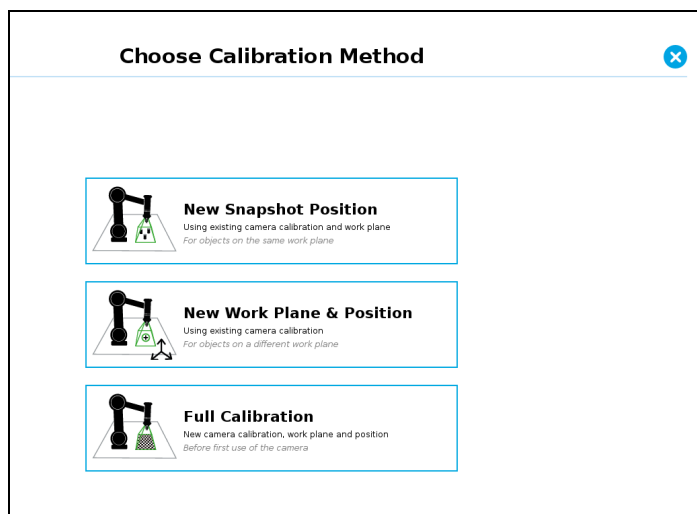

Fig. 6-2: You can calibrate using one of three methods.

**Caution**

You first need to perform a Full Calibration. Afterwards, you will be allowed to select any calibration method.

## 6.2.1 Performing a Full Calibration

1. Place calibration board (ACC-CALIB-BOARD) on the Wrist Camera work plane. Select the appropriate side for your Universal Robots model (see Fig. 6-3 and Fig. 6-4).

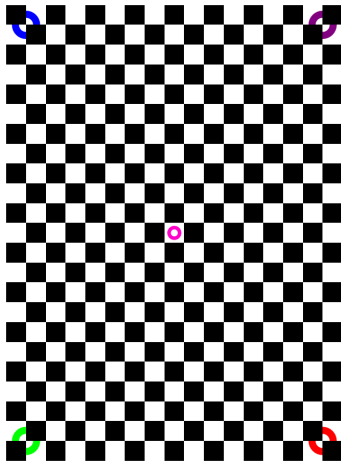

Fig. 6-3: This side of the calibration board is used for UR5 and UR10 Universal Robots models.



Fig. 6-4: This side of the calibration board is used for UR3 Universal Robots models. Color dots are not currently used by Robotiq software.

### Info

Calibration boards can be downloaded from [robotiq.com/support](https://robotiq.com/support). Select Wrist Camera > Accessories > Calibration Boards. From the dropdown list, choose either UR3 or UR5 & UR10 > DOWNLOAD PDF.

### Tip

To print a calibration board, follow these recommendations.

- The official Robotiq two-sided calibration board is 357 mm x 278mm. Print as "Ledger/Tabloid" or "A3" formats.
- Use matte paper.
- The calibration board can be printed with colors, grayscale or black and white.
- Do not scale the image.
- After printing, use a ruler to measure the 100 mm line located at the bottom of the page. If your measure is not exactly 100 mm, the printed document cannot be used as a calibration board.

2. The "Define Camera Calibration" window is displayed. Tap Calibrate.





### Caution



Move your robot so that the Wrist Camera can see the whole calibration board.

### Tip

The button Hold to Align to Axis reorientates the Wrist Camera to make it parallel to an axis of the robot base.

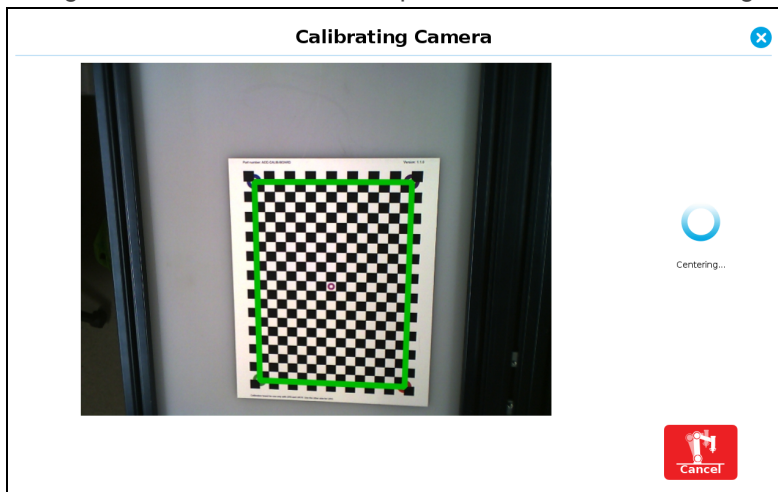
- The "Calibrating Camera" window is displayed, and the calibration process starts. Your robot moves around the calibration board, and the Vision System will take 27 pictures of the calibration board from different poses during 7-10 minutes. Then, 9 more pictures are taken for validating.



- The "Verify Camera Calibration" window is displayed. Tap Accept to go to the next step, or tap Re-calibrate to redo the calibration process. You can see all pictures taken during the calibration process by scrolling through them with  and .

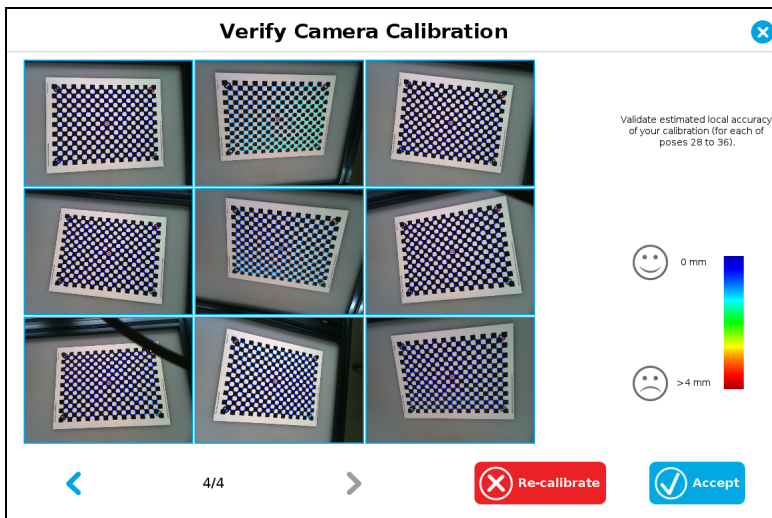

The wizard shows nine validation poses. Check the accuracy of validation poses:

- Dark blue: local accuracy of +/-0mm.
- Dark red: local accuracy of +/-4mm and over.

If the accuracy is larger than +/- 4mm, you are told that you should recalibrate. Tap Accept to complete the calibration process.

## 6.3. Saving the Snapshot Position

Toggle grid display by tapping Show Grid or Hide Grid. Objects to locate must completely fill at least one grid square, as smaller objects are difficult to detect. To re-align the Wrist Camera at this step, tap Hold to Align Over or otherwise move it. It is usually easier to teach objects when the Wrist Camera is aligned with its work plane. This position represents the coordinates and orientation of the Wrist Camera when using its nodes. When you are done, tap Save Position.

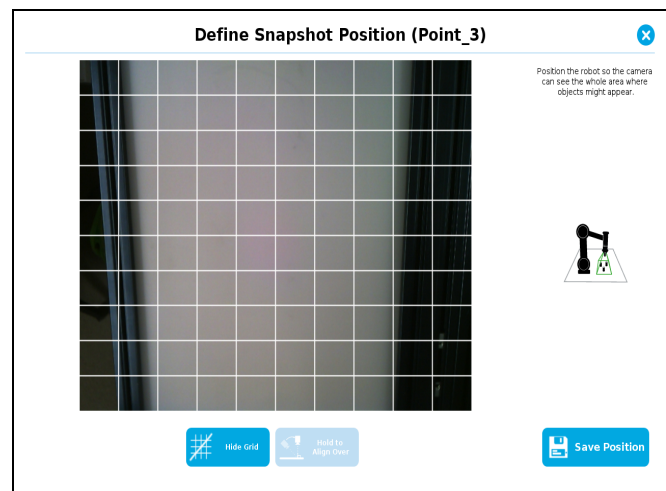
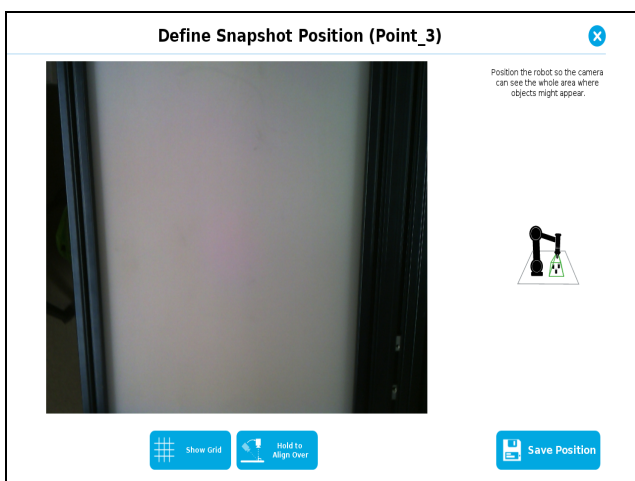

Once the calibration has been accepted, the snapshot position appears under the Snapshot tab with the same name as that of the feature point used for the calibration and snapshot process.

To permanently save the created snapshot position, tap Load/ Save from the Installation tab, and save the Installation file.





To remove a snapshot position from the Snapshot tab, select its thumbnail, then tap  .

#### Info

- You can teach as many snapshot positions as required.
- The snapshot position represents the coordinates (x, y, z) and orientation (Rx, Ry, Rz) of the Wrist Camera.
- A single snapshot position can be used to teach different objects.
- After completing the teaching process (see section **Object Teaching** on page 35), it is linked to the snapshot position; this locks the position.

## 6.3.1 Guidelines on Snapshot Position

During the snapshot position process, ambient light must be of approximately 500 lux. At run-time, this condition is not required. Snapshot position used for teaching objects may be different than the one used in production. However, camera angles and distances should be similar.

For example, conveyor areas are often hard to reach, causing object scanning issues. You can use a convenient area for object model teaching that will allow easy scanning. It is always possible to modify the final light and threshold adjustments at the runtime area. Set as `True` the variable `ignore_snapshot_position`. For details, see section **Cam Locate Node** on page 94.

For best results when choosing your snapshot position, follow these recommendations:

- Work plane
  - Mostly uniform color
  - Flat
  - Contrasts your part. For details, see section section **Vision System Specifications** on page 122.
- Distance to work plane
  - Your snapshot position determines the field of view of the Wrist Camera, and thus, the work plane.
    - For details on field of view and parts size, see section **Vision System Specifications** on page 1.
    - Moving closer to the work plane reduces workspace, but makes it easier to locate smaller objects.
    - Moving away from the work plane increases workspace and widens the area where objects can be detected, but makes it more difficult to locate smaller objects.
- Wrist Camera viewing angle
  - Wrist Camera should be perpendicular to work plane.
  - Select a snapshot position giving an overhead view of the object to locate, and setting a snapshot position to locate objects from the side.



---

# 7. Object Teaching

---

Once the snapshot position is defined (see section **Snapshot Position** on page 29), the operator can use the Cam Locatenode within a Universal Robots program to teach an object to locate.

## Requirements

- You must have completed the installation steps of section **Installation** on page 15
- Have in hand a few samples of the object to teach.

## Info

- One Cam Locate node is used per model taught .
- Object teaching is linked to a snapshot position. Changing this position will require you to reteach the object.
- The background used when teaching objects should provide a high contrast. You can use the yellow/pink background provided with the Wrist Camera. For details, see section **Snapshot Position** on page 29.

## 7.1 Guidelines on Object Teaching

### Info

During the object teaching, the ambient light must be approximately 500 lux, and stable. At runtime, this condition is not required.

The following must be considered when going through the object teaching process :

### 7.1.1 For a reliable localization

- Object is quasi-flat, respecting a maximum ratio of 1:1 between its height and its smallest dimension; see section **Vision System Specifications** on page 122 for more details.
- Top surface is mostly flat.
- Object has a distinctive shape (highly contrasts the background , is asymmetrical ) and distinctive features (e.g. holes, drawings, contrasting colors).
- Object has a matte finish.
- Object is not translucent.

### Tip

When teaching reflective objects, turn off LED to avoid bright, contrasting spots.

### 7.1.2. Choosing the appropriate background

- Workplane around the object must be planar, mostly uniform and clear of any other objects.



- At runtime, workspace conditions can change. The object detection threshold can be used to adjust detection settings according to those conditions; refer to the **Detection thresholds and scores** for details.
- The background around the object must be a uniform, continuous shape in a single color.

### Caution

For the Vision System, white, gray and black are all gradients of gray. Avoid using a black background to teach metal objects. The model would be a pale gray object on a dark gray background, and would therefore result in errors.

The Machine edge view feature shows edges seen by the Vision System in grayscale format. See section **Teach Object Wizard** on page **37** for more details. See section **Vision System Specifications** on page **122** for specifications on color contrast.

### Tip

Runtime tips:

- Use a simple, uniform background.
- Your work plane should contain as few objects and object types as possible. This will decrease cycle time.
- Ambient light should be diffuse.
- Avoid high contrast light spots on your background. Light spots make object detection slower, and cause errors.



## 7.2. Teach Object Wizard

### Cam Locate

To insert a Cam Locate node in the robot program follow these instructions.

#### CB-Series models

1. Start a new program or open yours, then go to the **Program** tab.
2. Tap the **Structure** tab URCaps > Cam Locate.

#### e-Series models

1. From the ribbon, tap **New** icon to create a robot program, or **Open** to load a program.
2. Select **Program**.
3. From the left navigation pane, tap **URCaps**.
4. Tap **Cam Locate**.
5. Select the node in the robot program, then tap the **Command** tab.
6. Tap **Edit** button to edit the node parameters.

### 7.2.1 Launching the Teach Object Wizard

#### Info

Snapshot position must be defined prior to launchin the object teaching wizard. For details, see section **Snapshot Position** on page 29

The Teach object wizard will guide you through the process of teaching an object that will be located by the Wrist Camera. To launch the wizard, tap the **Cam Locate** node > **Command** > **Teach object**.

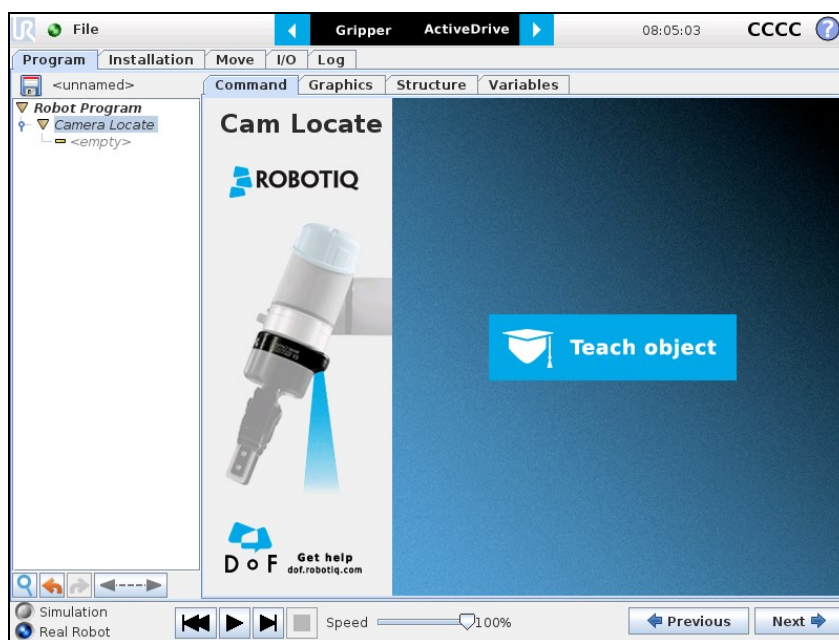

Fig. 7-1: The CB-Series Teach object wizard.



## 7.2.2. Selecting the Teach Method

- **Automatic method:** builds a model based on photos and a scan of the object. Best for complex and irregular shapes. Use this method if the object orientation has to be detected with one of its features. See section **Automatic Method** on page 38 for more details.
- **Parametric method:** builds a model based on parameters of a basic 2D shape (circle, ring, square or rectangle). This method is faster and allows the vision system to recognize and locate with high robustness objects that have few distinctive features such as raw material blanks. Usually gives better results than the Automatic Method for simple objects that are highly reflective. See section **Parametric Method** on page 71 for more details.

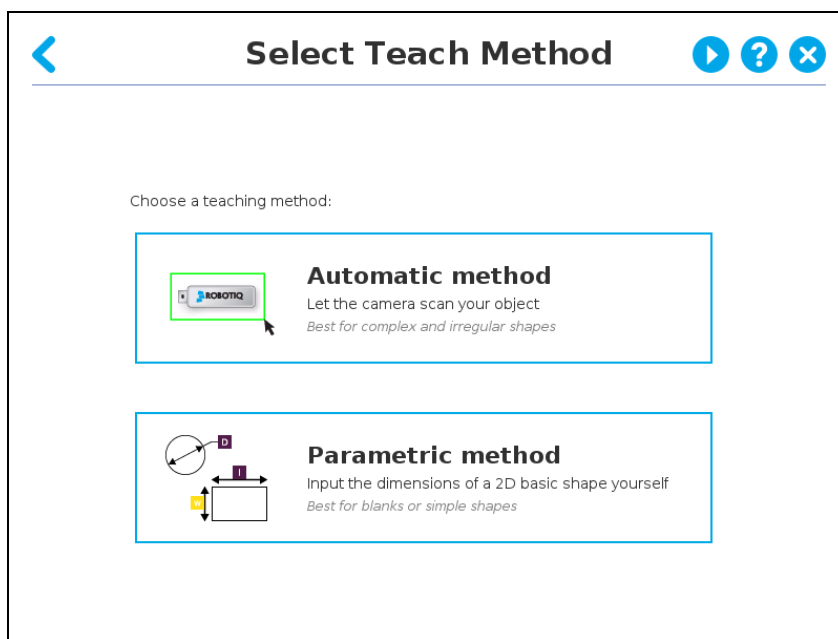

Fig. 7-2: Select either the Automatic or Parametric method to teach an object.

## 7.2.3. Automatic Method

### Caution

A Snapshot position must be defined to launch the object teaching wizard. If no Snapshot position has been defined, see **Snapshot Position**.

## Selecting a Calibration

Tap the **Snapshot position** you want to use.

### Info

If the robot is not at the snapshot position, you will be prompted to move to it. Tap and hold the **Move** button to do so.

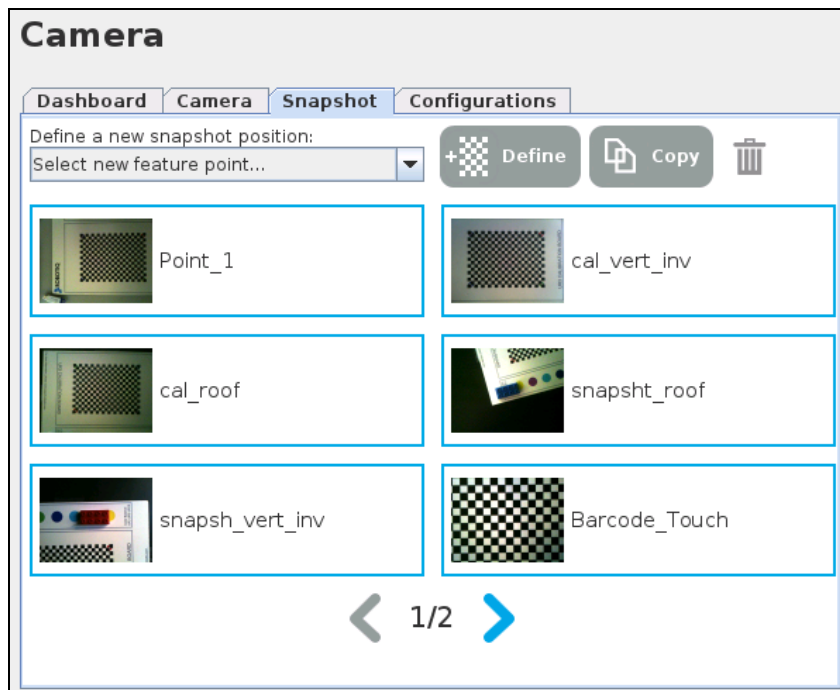









Fig. 7-3: CB-Series "Select Calibration" step.



## Selecting a Model

Prior to selecting a model, the user will place a background on the workplane and then position the object on the background. By default, the **Select Model** step displays the object to teach, automatically selected by the software, meaning a green selection rectangle overlaps the shape of the object.

	<b>Magic Wand</b> tool; see section <b>Automatic Area Selection</b> on page <b>40</b> for more details.
	<b>Tap and drag</b> tool; see section <b>Manual Area Selection</b> on page <b>42</b> for more details.
	<b>Zoom in</b> button; see section <b>Zooming In</b> on page <b>53</b> for more details.
	<b>Zoom out</b> button; see section <b>Zooming out</b> on page <b>54</b> for more details.
	<b>Accept model</b> button for finalizing the model selection step; see section <b>Accepting the model</b> on page <b>54</b> for more details.
	<b>Camera settings</b> button; see <b>Object Teaching</b> for more details.
	<b>Standard view</b> button; see section <b>Standard View</b> on page <b>42</b> for more details.
	<b>Machine edge view</b> button; see section <b>Machine Edge View</b> on page <b>44</b> for more details.
	<b>Machine color view</b> ; see section <b>Machine Color View</b> on page <b>46</b> for more details.

### Automatic Area Selection

The object is selected since the **Magic Wand** tool is enabled by default. The Magic Wand feature allows to locate objects on the background without user intervention.

### Info

For the automatic area selection feature to function properly, the user has to employ a uniform background, and a single object with well defined edges.

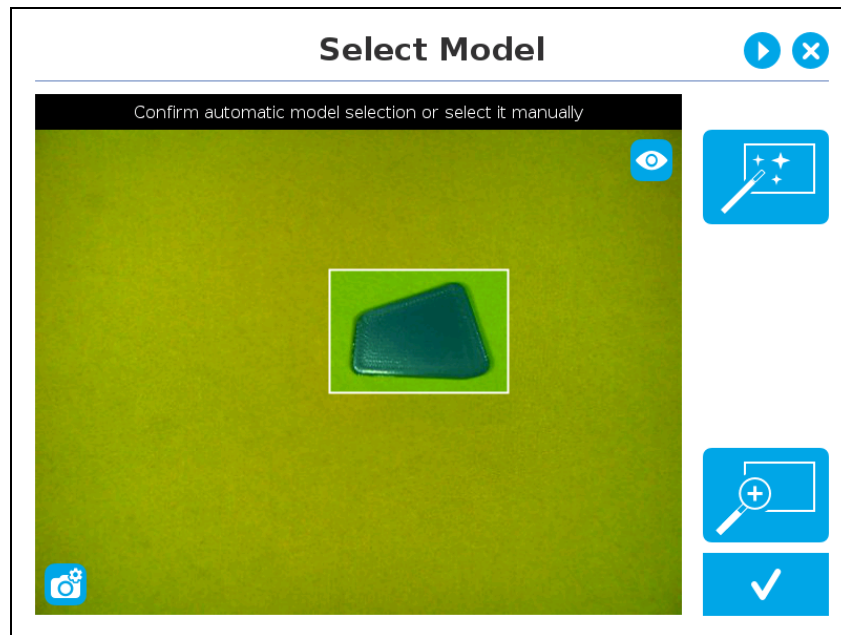



Fig. 7-4: Select Model step with object automatically selected by the Magic Wand tool.

### Info

Centering an object in the field of view often provides the best edges detection.

### Tip

Tapping  toggles to Manual area selection mode.

Tap  to switch to the Machine View to visualize edges detections and to optimize part location, depending on lighting setup.





## Manual Area Selection

Select an area by tapping the screen and dragging your finger over the object in the selection area.

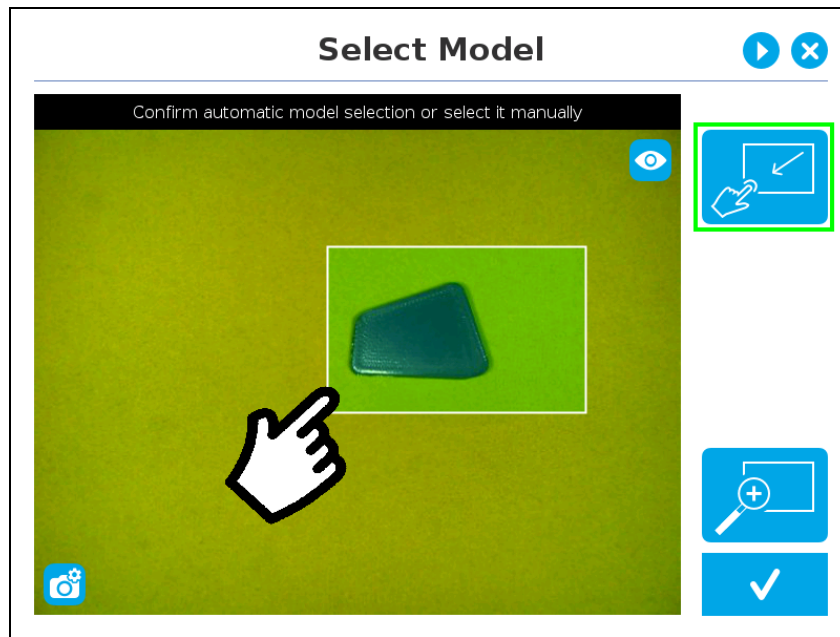

Fig. 7-5: Select Model step with Manual area selection feature

### Tip

The manual area selection is useful for careful inspection of specific features using the zoom function. See section **Zooming** on page 53 for more details.

The manual area selection can also be used for partial custom object selection (i.e. for selecting standalone features or components of an object).

Tapping the **Manual selection** button in the right pane toggles back to the "Automatic area selection" mode.

## Camera Viewing Modes

The following viewing modes are available for the Wrist Camera:

- Standard View
- Machine Edge View
- Machine Color view

### Standard View

When in standard view mode, the camera feed displays a reasonably faithful image based on what is normally perceived by the human eye (colored object on colored background).

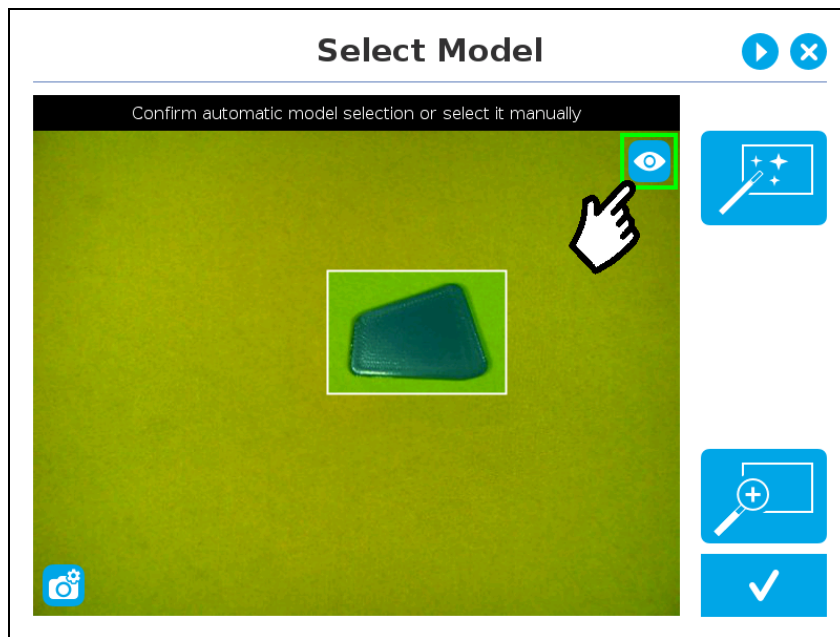



Fig. 7-6: Select Model step with standard view enabled

**Tip**

Tap  in the upper right corner of the camera feed window to display the **Machine view**.



## Machine Edge View

The user can access the **machine view** by tapping the **Color view** button in the upper right corner of the camera feed window. The machine view makes no discrimination between colors; it rather highlights the contour of the selected object.

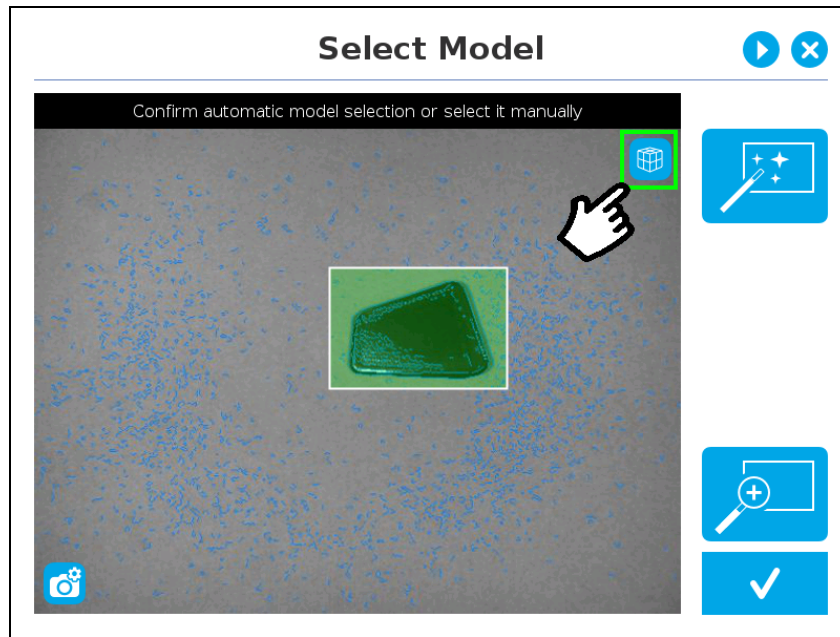













Fig. 7-7: Select Model step with Machine edge view enabled

### Tip

The Machine edge view is a convenient tool that can be used to better understand the quality of the image and the object contrast, and to improve adjustments made to the selection. Tap  to display the **Machine color view**.

## Camera Settings

To access advanced settings, tap  in the bottom left corner of the camera feed.

	Camera <b>LEDs</b> setting; see <b>Camera LED</b> for more details.
	Camera <b>Exposure</b> setting; see <b>Exposure</b> for more details.
	Camera <b>Focus</b> setting; see <b>Object Teaching</b> for more details.
	Camera <b>White Balance</b> setting; see <b>White Balance</b> for more details.
	The setting is in the <b>Automatic mode</b> ; please refer to the specific setting section for more details.
	The setting is in the <b>Manual mode</b> ; see specific setting section for more details.
	The setting is in the <b>Basic mode</b> ; see specific setting section for more details.
	The setting is in the <b>Expert mode</b> ; see specific setting section for more details.
	<b>Plus</b> button increases a value.
	<b>Minus</b> button decreases a value.
	Camera LEDs are <b>OFF</b> ; see section <b>Camera LED</b> on page <b>47</b> for more details.
	<b>Retake</b> button; the setting is reinitialized. Please refer to the specific setting section for more details



## Machine Color View

The user can access the **Machine color view** by tapping the **Machine edge view** button in the upper right corner of the camera feed window. The Machine color view displays the elementary colors perceived by the vision system.

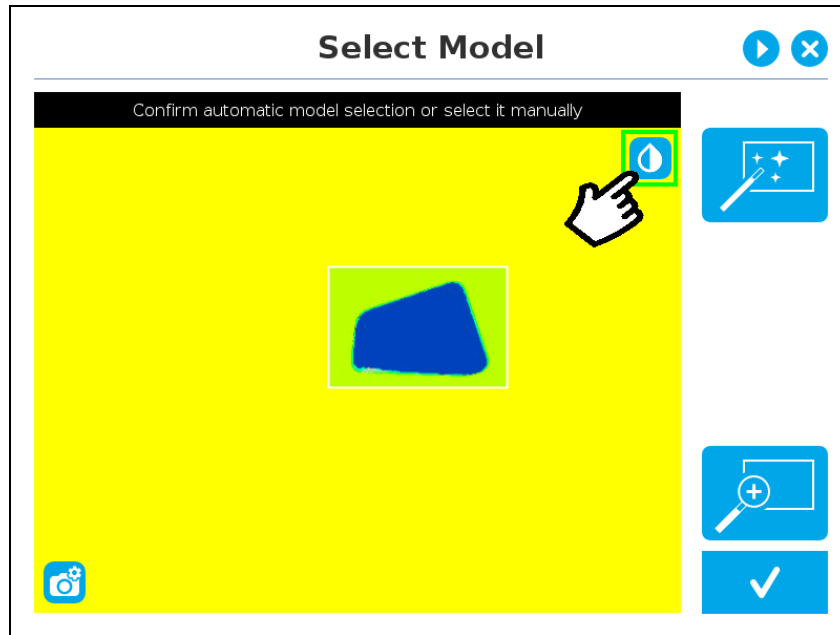



Fig. 7-8: "Select Model" step with Machine color view enabled.

### Tip

The Machine color view helps to understand the color signature and scale used by the system.

Tap  to display the **Standard view**.

## Camera LED

In addition to the **Auto** and **Off** settings of the Basic mode, **Expert mode** provides camera LEDs' intensity adjustment. The touch-sensitive slider can be used to select the right intensity more easily.

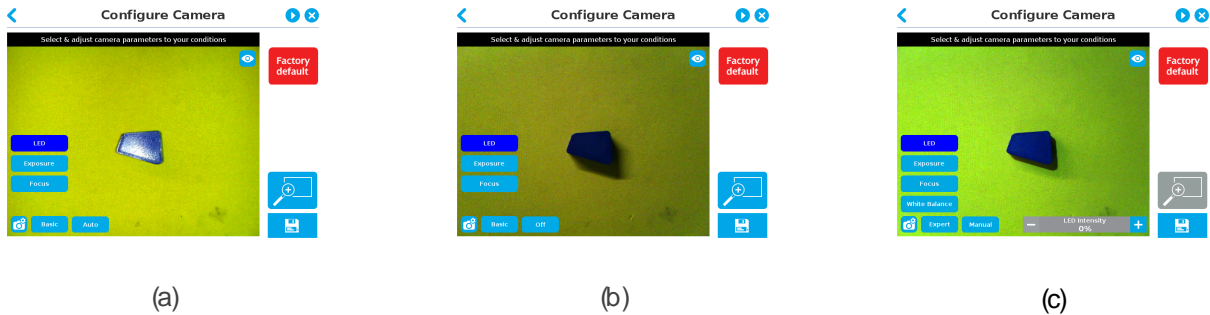

Fig. 7-9: Select Model step with LED option enabled; (a) Auto, (b) OFF, and (c) Manual

### Tip

When turned ON, LED sometimes highlight undesirable features or create reflections that can mask desired features of the image. It is recommended to try multiple settings, including the ON/OFF mode, when teaching the object in order to select the most conclusive result.

### Warning

The flash and focus settings selected will be used at runtime unless changes are made at the **Configure Model** step at the end of the teaching process. Please refer to the **Configuring the Model** for more details.



## Exposure

The exposure value (EV) can be changed using the slider to obtain the desired contrast and to avoid reflexions.



Fig. 7-10: Select Model step with Exposure option enabled (Basic mode); (a) -3EV and (b) 3EV

For more control, the **Expert mode** also provides manual Exposure capability. It allows the user to directly modify the exposure or the gain and keep them fixed. A **Retake** button is also available in the Expert mode. This function enables to adjust the manual settings according to the last automatic exposure value. If the **Manual mode** is selected, the exposure time ( $\mu\text{s}$ ) and the gain can be modified independently. The exposure time is the duration (in microsecond) of the sensor's light exposure. On the other hand, the gain represents the electrical amplification of the analog signal from the camera sensor. It converts the analog signal to a digital signal. It should be noted that the amplification of the signal also increases the ambient noise.

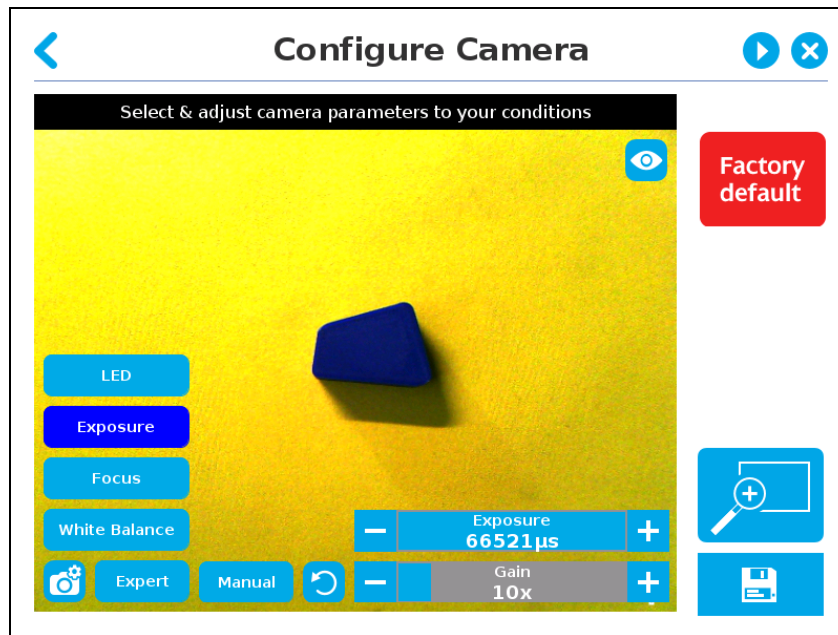

Fig. 7-11: Select Model step with Exposure option enabled (Expert and Manual modes enabled)

It is possible to reduce or eliminate camera image flicker (also seen as vertical moving bands) by matching camera exposure time with illumination frequency. See the following table to match exposure time and current frequency (50/60Hz).

Exposure time (ms)		
Category	50 Hz	60 Hz
Short Exposure	10.0	8.333
	20.0	16.667
Medium Exposure	30.0	25.0
	40.0	33.333
Long Exposure	50.0	41.667
	60.0	50.0
	N/A	58.333

Table 7-1: Suggested Exposure time versus Current Frequency (Hz).

**Tip**

To improve image quality, it is recommended to increase exposure time before increasing gain.

**Info**

The exposure value (EV) represents a combination of exposure time and digital gain. Simply put, increase EV to make images brighter.





## Focussing

### Info

Focus features can be used to sharpen or diminish the contrast between the object and the background, and adjust the depth of field. The settings will be captured at runtime except if changes are made to the model during the **Configure Model** step. See section **Configuring the Model** on page 75 for more details.

### Automatic Focus

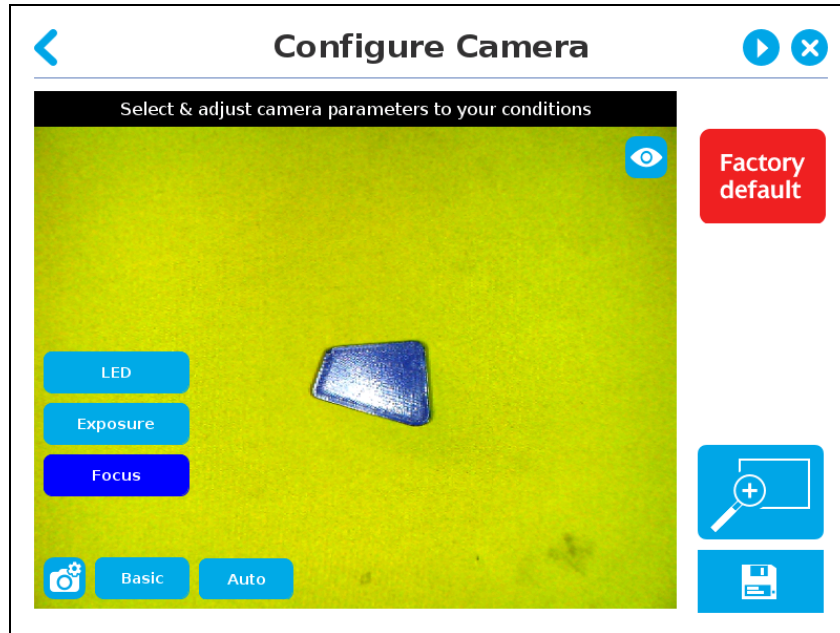

Fig. 7-12: Select Model step with automatic focus option enabled.

To some extent, the automatic focus feature detects sharpness in the overall image. If the image is blurry, the autofocus system will adjust the focus until sharpness and/or contrast is achieved. This type of automatic focus requires enough contrast between the object and the background for it to render an appropriate image.

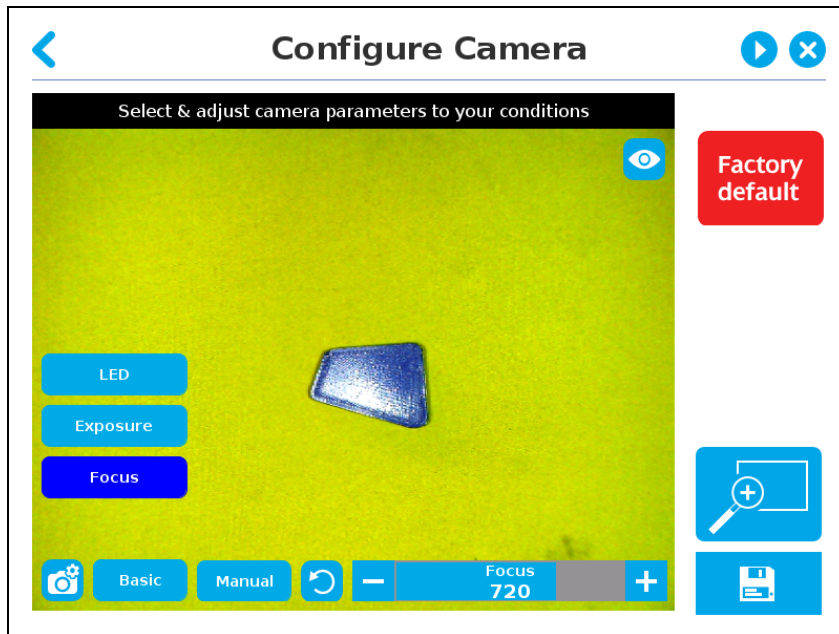

Fig. 7-13: Select Model step with manual focus option enabled

By clicking on the **Auto** button, the system makes an auto-focus before changing to the **Manual mode** status. The manual focus feature adjusts the depth of field at the focus point.

By clicking on the **Retake** button, the system refreshes the focus to the optimal result.

**Tip**

The Focus adjustment slider is touch-sensitive. The position touched on the the slider area will determine the desired value. For finest possible adjustment, the +/- buttons can be used.

**White Balance**

White Balance is a parameter to get appropriate colors and better-defined shades of grey. It is always in Automatic but manual setting can be done in the Expert mode. This can be done by clicking on the Basic button. In this mode, three sliders, each representing a different color (red, green, blue) are available to adjust the level of their own color.

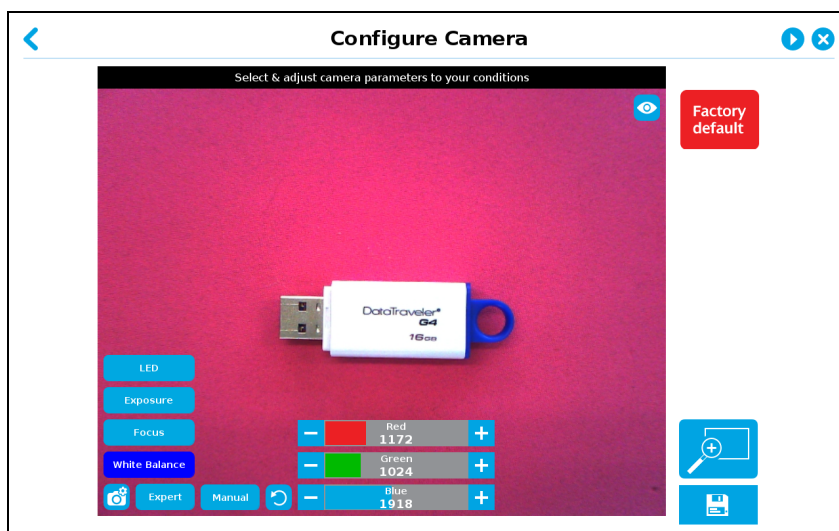
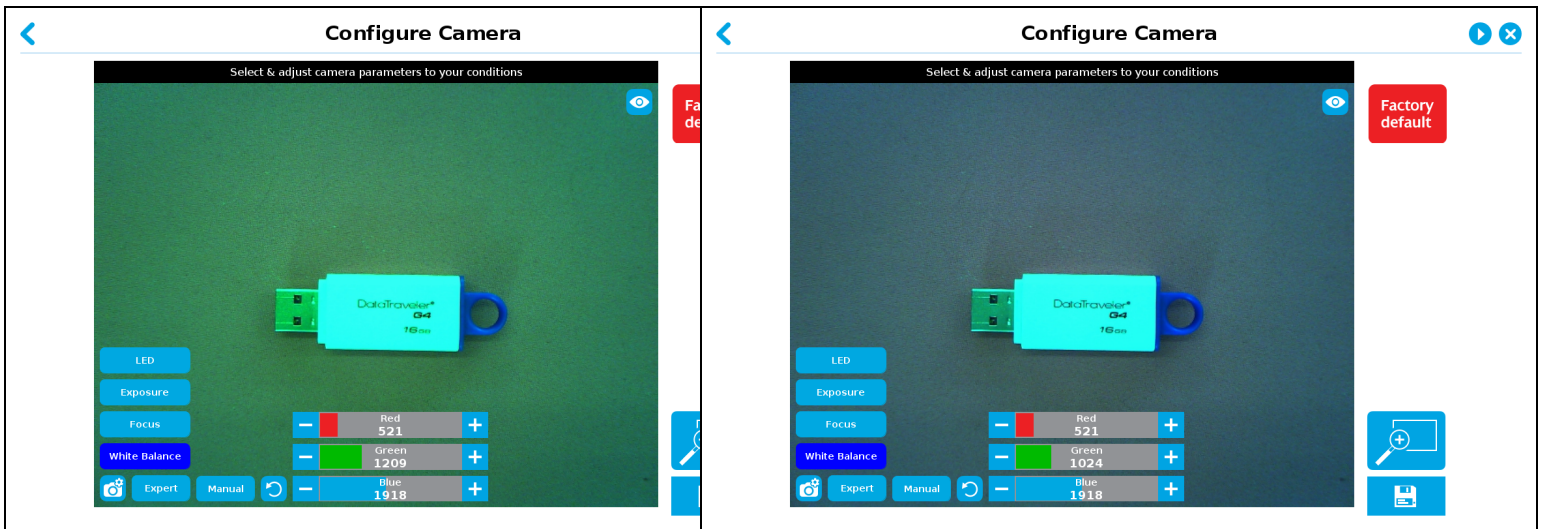

Fig. 7-14: Select Model step with White Balance option enabled (Manual mode enabled)





(a)

(b)

Fig. 7-15: White Balance configured with (a) less red color and more green (b) less red only

**Tip**

When teaching metallic objects, using the pink mat will increase the contrast between the part and the background. Reduce the red channel and increase the green one to optimize the contrast of a shiny metallic object. Use the Machine View to adjust these parameters.

## Zooming

The zoom-in/zoom-out tool is used to toggle between a high-level view and a more explicit view of the selection area (and object).

### Zooming In

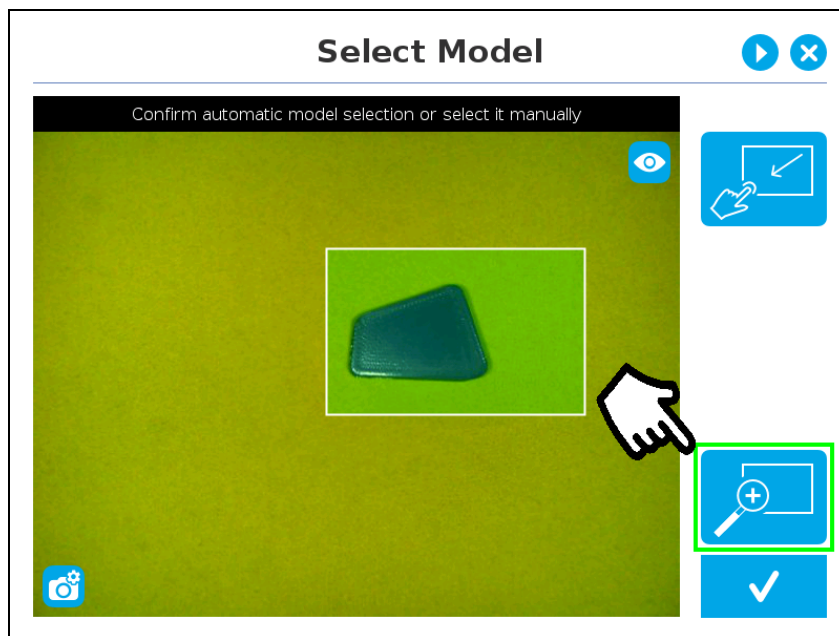

*Fig. 7-16: Select Model step with Zoom in button highlighted*

In order to zoom in on the selection area, the user has to tap the magnifier with a plus symbol in the lower right corner of the teach pendant interface.

Once zoomed in, the user can perform focus adjustments to improve the recognition of edges in the model.

#### Info

Note that when zoomed in, the user can neither change the area selection mode nor accept the model selected (the buttons are greyed out). The zoom in feature is therefore solely used for inspecting the model in details and for adjusting the depth of field via the manual focus settings.



## Zooming out

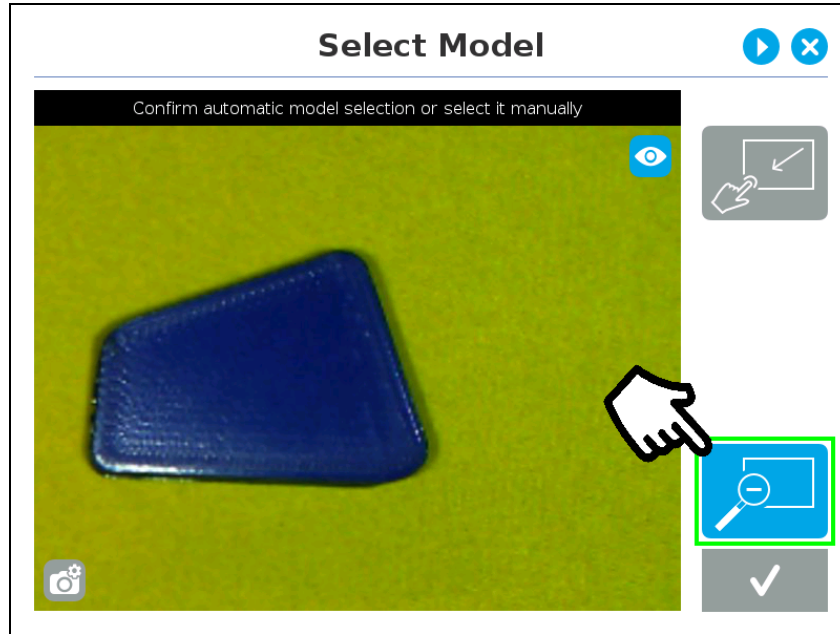



Fig. 7-17: Select Model step with Zoom out button highlighted

In order to zoom out from the selection area, the user has to tap the magnifier with a minus symbol in the lower right corner of the teach pendant interface.

## Accepting the model

To accept the model, and proceed to the next step of the wizard, tap .

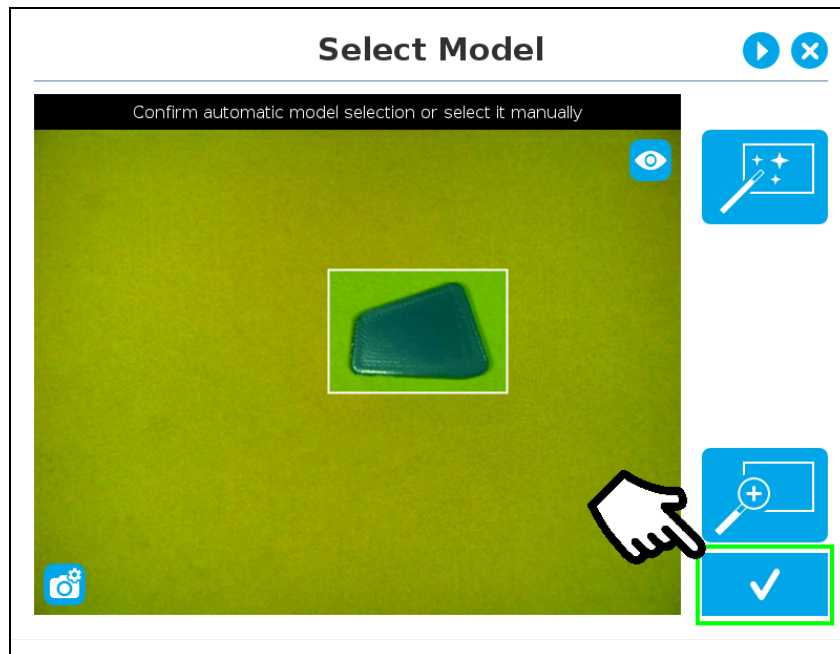

Fig. 7-18: Select Model step with Accept button highlighted









## Summary of Camera Settings

Parameters	Adjustment	Range	Basic	Expert
Mode	Basic		Yes	
	Expert			Yes
Exposure	Sensitivity	Auto -7...0...+7 Exposure Sensitivity 0EV	Yes	Yes
	Time	Manual 0...66,604 µs Exposition 66604µs		Yes
	Sensor Gain	Manual 1x ... 63x Gain 10x		Yes
	Manual Trigger	Uses active Auto Sensitivity Setting		Yes
Focus	Automatic	Auto	Yes	Yes
	Manual	Manual 0...1023 Focus 711	Yes	Yes
	Manual Trigger		Yes	Yes
LED	Automatic	Auto	Yes	Yes
	Off	off	Yes	Yes
	Manual Trigger	Manual 0...100% 0%: min. val. LED Intensity 0%		Yes
White Balance	Automatic	Auto		Yes
	Manual: RGB	Manual 0...4095 3x	Red 1303	
			Green 1024	
			Blue 1793	
Manual Trigger		*Locked when defining color in Color validation		



## Editing the Model

After accepting a model, the camera automatically zooms in on selected object . Tools are available.

	<b>Outline only</b> selection mode; please refer to the <b>Object Teaching</b> for more details.
	<b>Outline &amp; surface</b> selection model please refer to the <b>Object Teaching</b> for more details.
	<b>Rectangle selection around object</b> please refer to the <b>Object Teaching</b> for more details.
	<b>Marker</b> tool; please refer to the <b>Object Teaching</b> for more details.
	<b>Eraser</b> tool; please refer to the <b>Object Teaching</b> for more details.
	<b>Rectangle+ (add area)</b> tool; please refer to the <b>Object Teaching</b> for more details.
	<b>Accept model</b> button; please refer to the <b>Accepting the model</b> for more details.
	<b>Delete selection area</b> button; please refer to the <b>Accepting the model</b> for more details.

### Info

For details on toggling color/machine view while editing a model, see To ternate between color and machine view while editing the model, see section **Object Teaching** on page 35.



## Quick Selection Modes

Tap the arrow to the left of the quick selection tool to expand the selection modes menu.

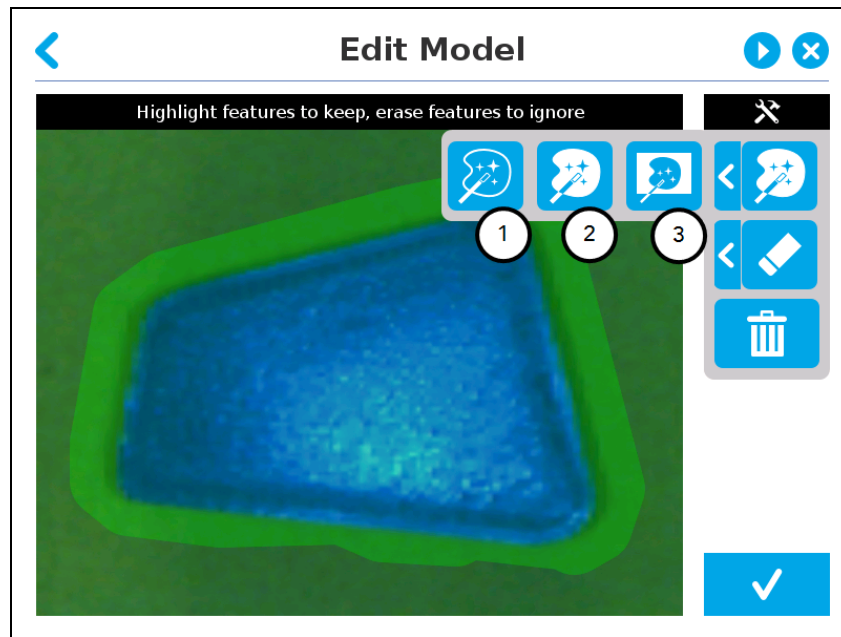

Fig. 7-19: Edit Model step with quick selection modes expanded.

### 1. Outline only

The Outline only selection tool is used to highlight the contour of the object. The selection area bleeds off the edge of the object to capture the background color. The **Outline only** selection tool is not available for an object that has been selected manually at the "Select Model" step. This prevents users from selecting the partial contour of an object, which could lead to faulty contrasts and edge detection.

### 2. Outline & surface

The Outline & surface selection tool is used to highlight the contour and upper surface of the object. Tap the middle button. This tool is selected by default when the user accepts a model selected automatically during the Select Model step. The selection area bleeds off the edge of the object to capture the background color. The **Outline & surface** selection tool is not available for an object that has been selected manually at the "Select Model" step. This prevents users from selecting the partial outline and/or surface of an object, which could lead to faulty contrasts and edge detection.

### 3. Rectangle around object

The Rectangle around object selection tool generates a rectangular selection area surrounding the object. The **Rectangle around object** selection tool is automatically selected when the object has been manually selected at the "Select Model" step.

## Tools

Tap the arrow to the left of the tools button to expand the tools menu.





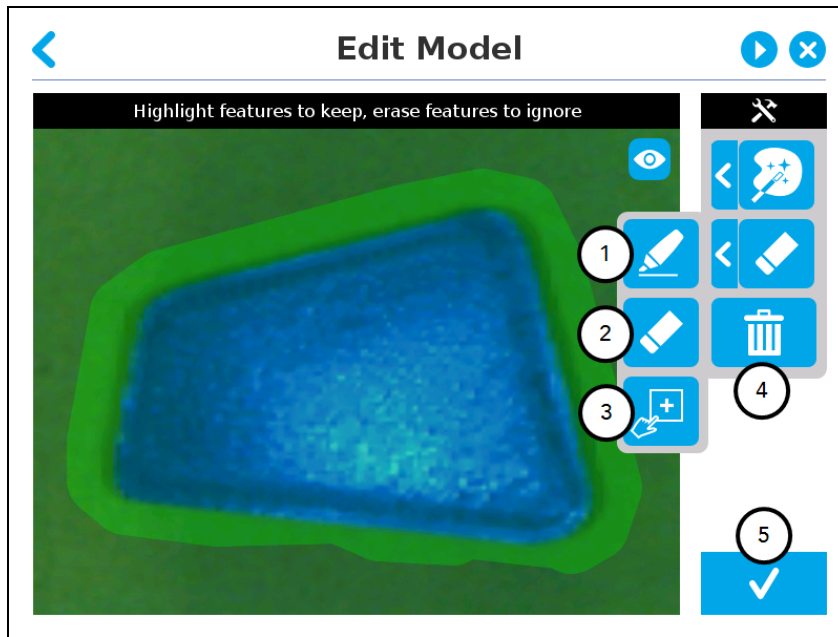

Fig. 7-20: Edit Model step with tools menu expanded

1. **Marker**

The marker tool can be used to highlight features and edges to **include and keep** in the selection area.

Slide your finger or pointing device on the desired area(s) on the teach pendant. A green **object layer mask** will be applied to the highlighted portion of the model.

2. **Eraser**

The eraser tool can be used to ignore features and edges in the selection area.

Slide your finger or pointing device on the undesired area(s) on the teach pendant. The object layer mask will be replaced by the background layer mask.

3. **Rectangle+** (add area)

The rectangle+ (add area) tool can be used to quickly highlight desired areas.

Tap and drag your finger or pointing device to draw rectangular shapes that will highlight presently available features.

## Deleting the Selection Area

4. **Garbage can**

Tap  to clear the object layer mask, thus deleting the selection area.

## Accepting the model

5. **Check mark**

When the view of the model is satisfactory and you wish to carry on with the teaching wizard steps, tap the button with the check mark in the lower right corner of the teach pendant interface.

### Caution

Tap  to take a picture of the model that will act as the first step in the next phase of the teaching process: "Refine Model".



## Refining the Model

The "Refine Model" step prompts the user to take photos of the model in four different orientations. The purpose of this step is to remove shade effects associated with the edges of the object in order to refine the model.

### Info

The first photo is automatically generated at the end of the Edit Model step.

Tap the camera icon to take a photo between each step. An error will pop up if the object has not been rotated.

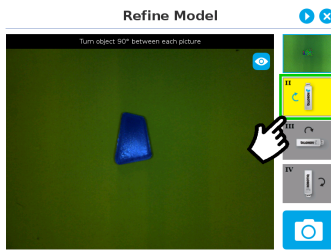

1. The user is prompted to turn the object 90 degrees clockwise. Note that the first picture is already taken, in the upper right corner.

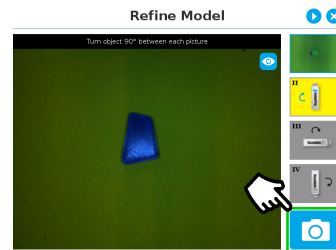

2. The user is prompted to take the second picture of the object.

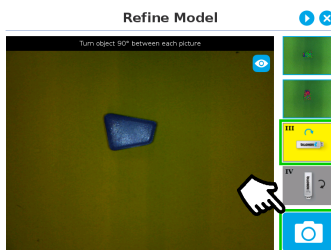

3. Object turned another 90 degrees clockwise. The user is prompted to take the third picture.

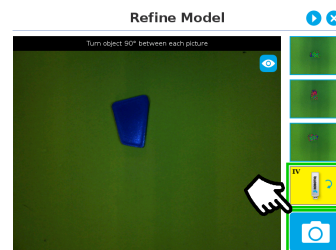

4. Object turned another 90 degrees clockwise. The user is prompted to take the fourth picture.

### Tip

For best results, keep the object centered between rotations.

Tap on any snapshot taken in the object teaching wizard to enlarge it.



## Validating the Model

The Validate Model step starts after the fourth picture is taken at the end of the Refine Model step.

### Info

If the object is properly detected, it will display green and red outlines.

If the object has not been recognized, please refer to the **Guidelines on Object Teaching** for instructions.

	<b>Accept</b> button
	<b>Retake</b> button

The Validate Model step is used to verify the contour selection of the model. If satisfactory, the user can accept the model by pressing the **Accept** button, or go through the Refine Model step again by tapping the **Retake** button.



Check the following:

- Object contours and detected features are outlined in green
- Features from the model that cannot be located on the object in the field of view of the camera are outlined in red.

## Scanning the Model

### Warning

Scanning is an automatic process; the robot will move in order to perform calibration. Make sure the robot work space is clear. Tap  to stop the process. The operator should watch the robot at all times and have the emergency stop button at hand.

	<b>Scan button</b> used to start the scanning process
	<b>Cancel button</b> used to abort the scanning process while it is running



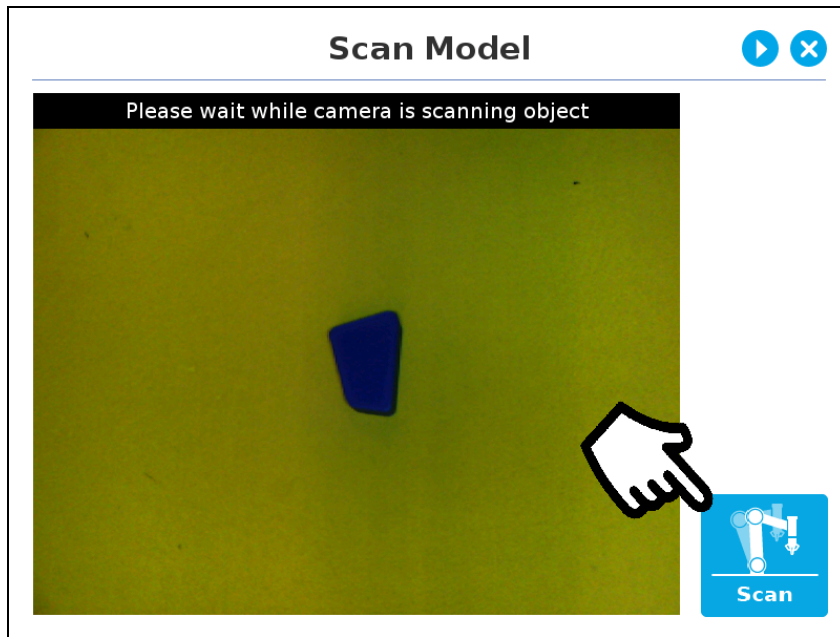

Fig. 7-21: Scan Model step with Scan button highlighted

The Vision System scans the object by taking 9 pictures.

When the process is completed, the wizard will bring up the **Configure Model** step. Please refer to the **Configuring the Model** for more information.

## Camera LED

In addition to the **Auto** and **Off** settings of the Basic mode, **Expert mode** provides camera LEDs' intensity adjustment. The touch-sensitive slider can be used to select the right intensity more easily.

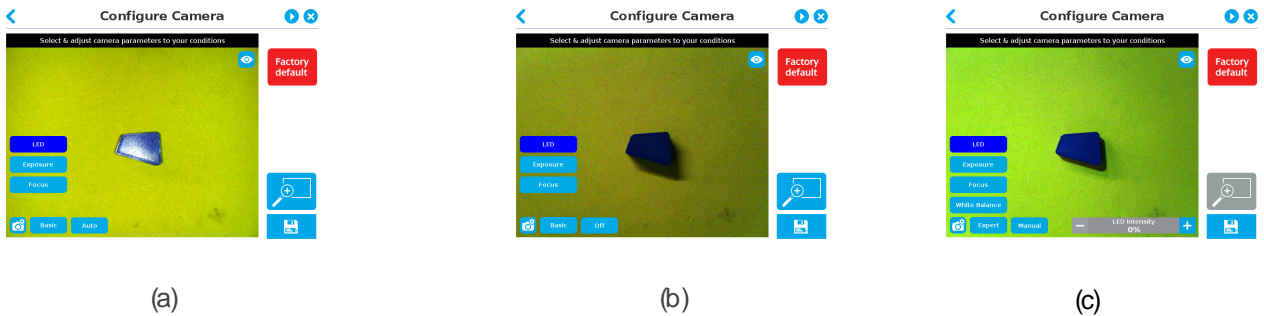

Fig. 7-22: Select Model step with LED option enabled; (a) Auto, (b) OFF, and (c) Manual

### Tip

When turned ON, the LED sometimes highlight undesirable features or create reflections that can mask desired features of the image. It is recommended to try multiple settings, including the ON/OFF mode, when teaching the object in order to select the most conclusive result.

### Warning

The flash and focus settings selected will be used at runtime unless changes are made at the **Configure Model** step at the end of the teaching process.

Please refer to the **Configuring the Model** for more details.

## Accepting the model

When the view of the model selected is satisfactory and you wish to carry on with the teaching wizard steps, tap the button with the **check mark** in the lower right corner of the teach pendant interface.

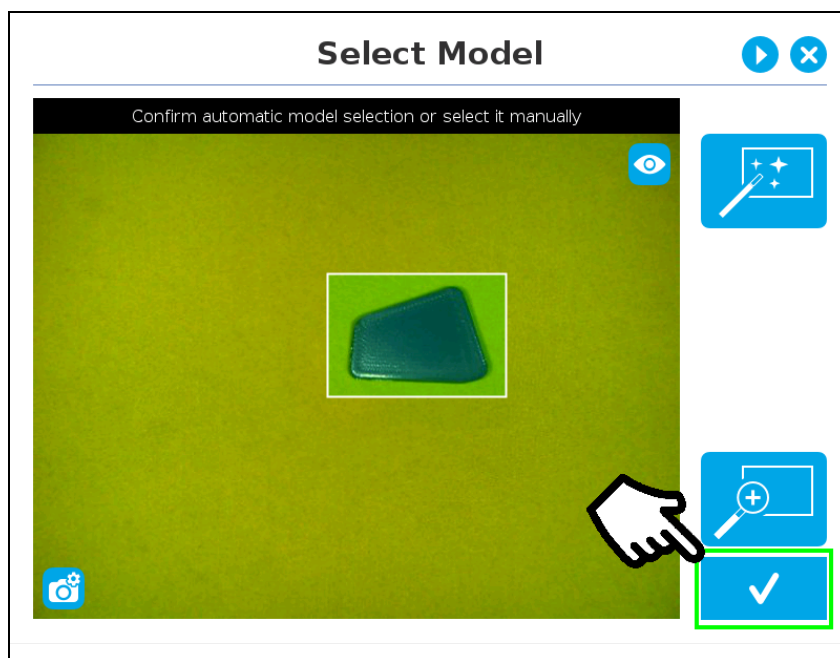

Fig. 7-23: Select Model step with Accept button highlighted











## Camera Settings Summary

Parameters	Adjustment	Range	Basic	Expert		
Mode	Basic		Yes			
	Expert			Yes		
Exposure	Sensitivity	Auto	-7...0...+7	Exposure Sensitivity 0EV	Yes	Yes
	Time	Manual	0...66,604 μs	Exposition 66604 μs		Yes
	Sensor Gain	Manual	1x ... 63x	Gain 10x		Yes
	Manual Trigger		Uses active Auto Sensitivity Setting			Yes
Focus	Automatic	Auto			Yes	Yes
	Manual	Manual	0...1023	Focus 711	Yes	Yes
	Manual Trigger				Yes	Yes
LED	Automatic	Auto			Yes	Yes
	Off	off			Yes	Yes
	Manual Trigger	Manual	0...100% 0%: min. val.	LED Intensity 0%		Yes
White Balance	Automatic	Auto				Yes
	Manual: RGB	Manual	0...4095 3x	Red 1303		Yes
				Green 1024		
				Blue 1793		
Manual Trigger				*Locked when defining color in Color validation		

## Editing the Model

Right after accepting the model at the end of the Select Model step, the camera automatically zooms in on the object selected. Quick selection modes and tools are made available to the user.

	<b>Outline only</b> selection mode; please refer to the <b>Object Teaching</b> for more details.
	<b>Outline &amp; surface</b> selection model please refer to the <b>Object Teaching</b> for more details.
	<b>Rectangle selection around object</b> please refer to the <b>Object Teaching</b> for more details.
	<b>Marker</b> tool; please refer to the <b>Object Teaching</b> for more details.
	<b>Eraser</b> tool; please refer to the <b>Object Teaching</b> for more details.
	<b>Rectangle+ (add area)</b> tool; please refer to the <b>Object Teaching</b> for more details.
	<b>Accept model</b> button; please refer to the <b>Accepting the model</b> for more details.
	<b>Delete selection area</b> button; please refer to the <b>Accepting the model</b> for more details.





### Info

The user can alternate between color and machine view while editing the model. Please refer to the **Object Teaching** for more details.



## Quick selection modes

Tap the arrow to the left of the quick selection tool to expand the selection modes menu.

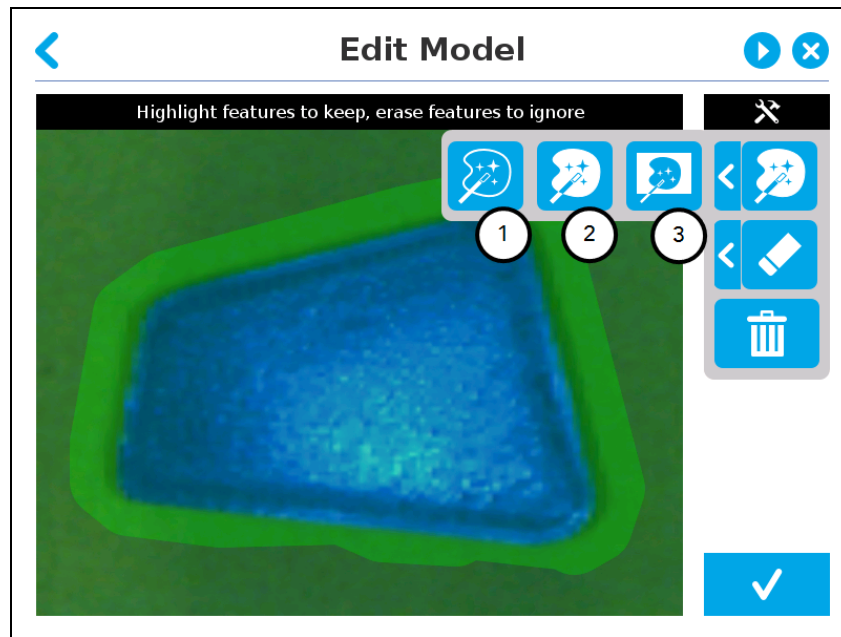

Fig. 7-24: Edit Model step with quick selection modes expanded.

### 1. Outline only

The Outline only selection tool is used to highlight the contour of the object. The selection area bleeds off the edge of the object to capture the background color. The **Outline only** selection tool is not available for an object that has been selected manually at the "Select Model" step. This prevents users from selecting the partial contour of an object, which could lead to faulty contrasts and edge detection.

The Outline only selection tool is used to highlight the contour of the object.

### 2. Outline & surface

The Outline & surface selection tool is used to highlight the contour and upper surface of the object. Tap the middle button. This tool is selected by default when the user accepts a model selected automatically during the Select Model step. The selection area bleeds off the edge of the object to capture the background color. The **Outline & surface** selection tool is not available for an object that has been selected manually at the "Select Model" step. This prevents users from selecting the partial outline and/or surface of an object, which could lead to faulty contrasts and edge detection.

### 3. Rectangle around object

The Rectangle around object selection tool generates a rectangular selection area surrounding the object.

#### Info

The **Rectangle around object** selection tool is automatically selected when the object has been manually selected at the Select Model step.

## Tools

Tap the arrow to the left of the tools button to expand the tools menu.



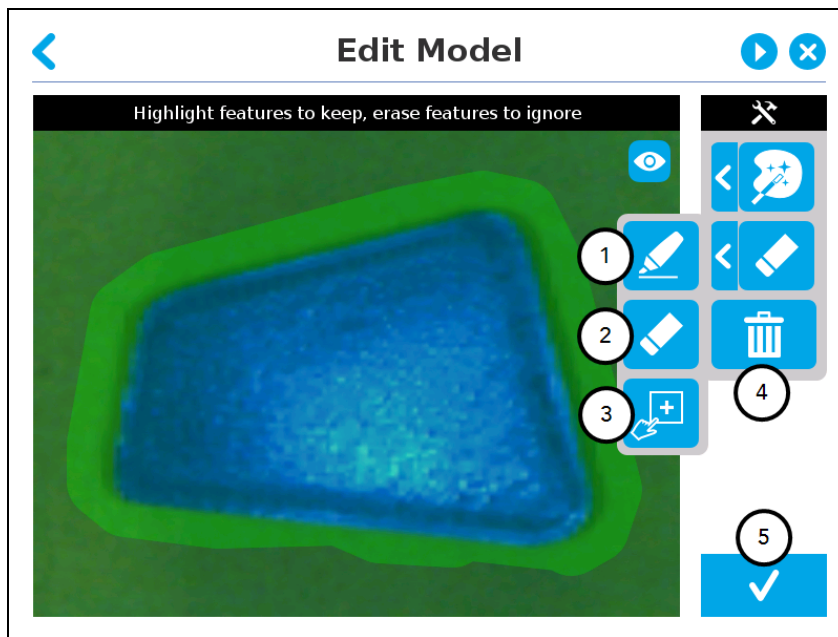

Fig. 7-25: Edit Model step with tools menu expanded

#### 1. Marker

The marker tool can be used to highlight features and edges to **include and keep** in the selection area.

Slide your finger or pointing device on the desired area(s) on the teach pendant. A green **object layer mask** will be applied to the highlighted portion of the model.

#### 2. Eraser

The eraser tool can be used to ignore features and edges in the selection area.

Slide your finger or pointing device on the undesired area(s) on the teach pendant. The object layer mask will be replaced by the background layer mask.

#### 3. Rectangle+ (add area)

The rectangle+ (add area) tool can be used to quickly highlight desired areas.

Tap and drag your finger or pointing device to draw rectangular shapes that will highlight presently available features.

### Deleting the Selection Area

Tap the garbage can button to clear the selection area.

### Accepting the Model

#### 4. Check mark

When the view of the model is satisfactory and you wish to carry on with the teaching wizard steps, tap the button with the check mark in the lower right corner of the teach pendant interface.

#### Caution

Tapping  takes a picture of the model that will act as the first step in the next phase of the teaching process: Refine Model.

## Refining the Model

The Refine Model step prompts the user to take photos of the model in four different orientations. The purpose of this step is to remove shade effects associated with the edges of the object in order to refine the model.

### Info

The first photo is automatically generated at the end of the Edit Model step.

### Info

Tap the camera icon to take a photo between each step. An error will pop up if the object has not been rotated.

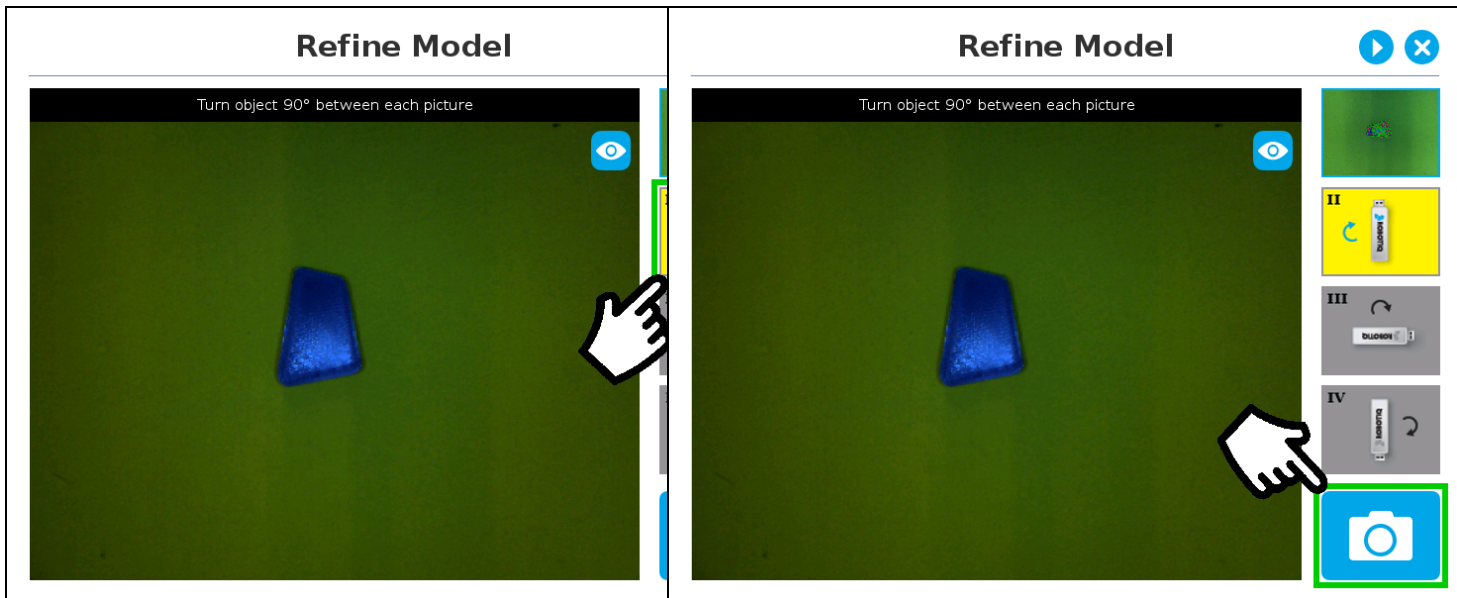

1. The user is prompted to turn the object 90 degrees clockwise. Note that the first picture is already taken, in the upper right corner.

2. The user is prompted to take the second picture of the object.



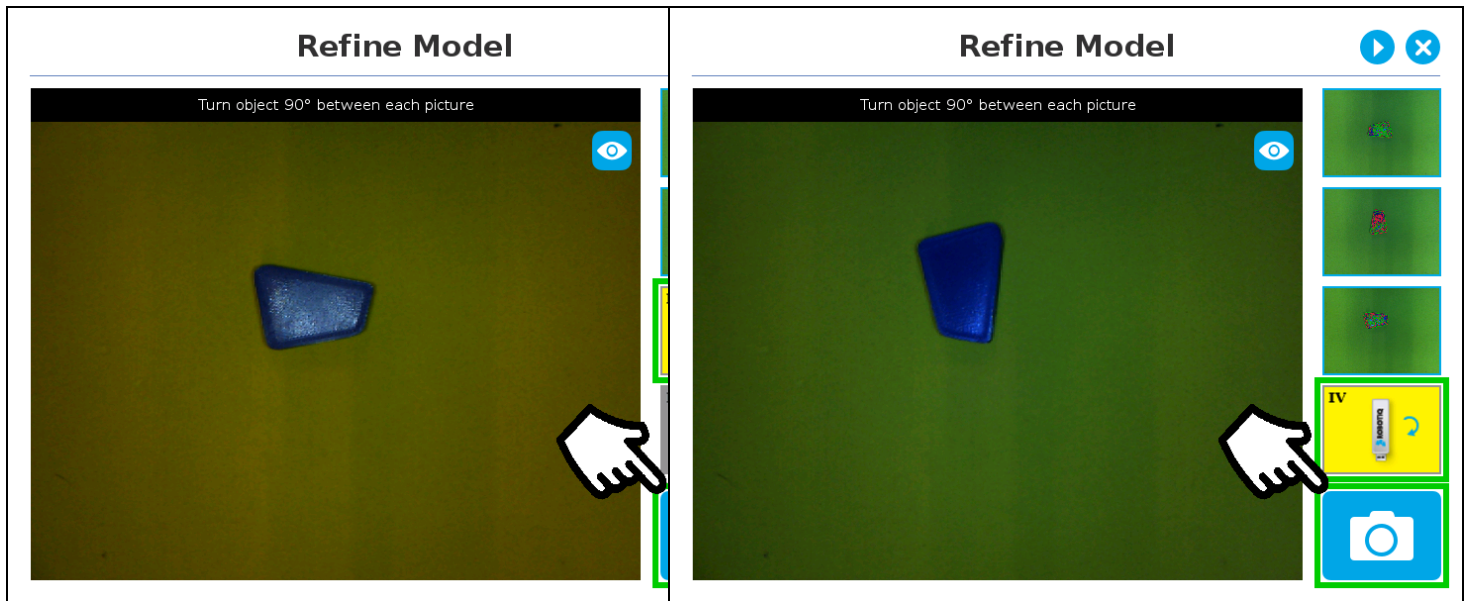

3. Object turned another 90 degrees clockwise. The user is prompted to take the third picture.

4. Object turned another 90 degrees clockwise. The user is prompted to take the fourth picture.

**Tip**

For best results, keep the object centered between rotations.

Tap on any snapshot taken in the object teaching wizard to enlarge it.



## Validating the Model

The Validate Model step will start right after the fourth picture is taken at the end of the Refine Model step.

**Info**

If the object is properly detected, it will display green and red outlines. If the object has not been recognized, see section **Guidelines on Object Teaching** on page 35 for instructions.

	Accept button
	Retake button

The Validate Model step is used to verify the contour selection of the model. To accept the model, tap . To go back to "Refine Model", tap .

Object contours and detected features are outlined in green, while features that cannot be located on the object in the field of view are outlined in red.

## Scanning the Model

### Warning

Scanning is an automated process; the robot will move in order to perform calibration. Make sure the robot's work space is clear. Tap  to stop the process. The operator should watch the robot at all time and have the emergency stop button at hand.

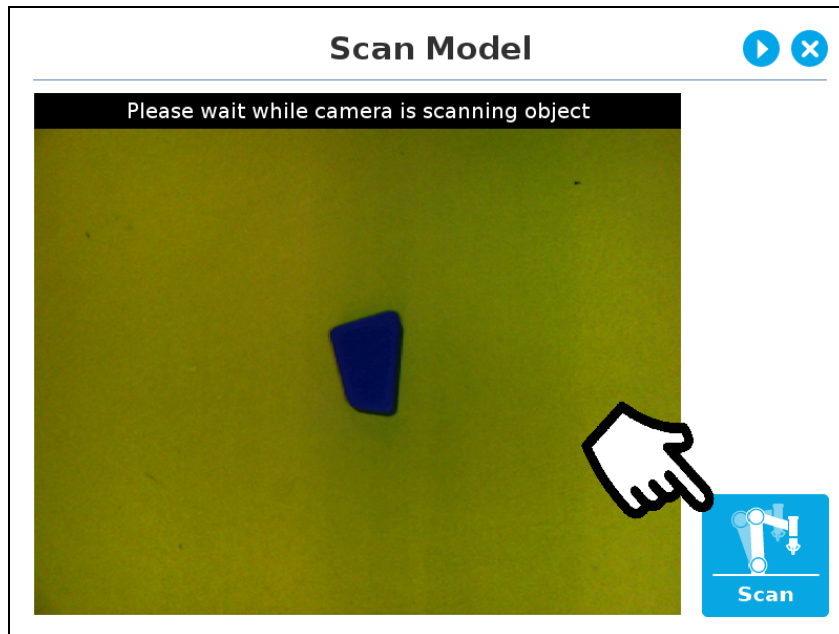
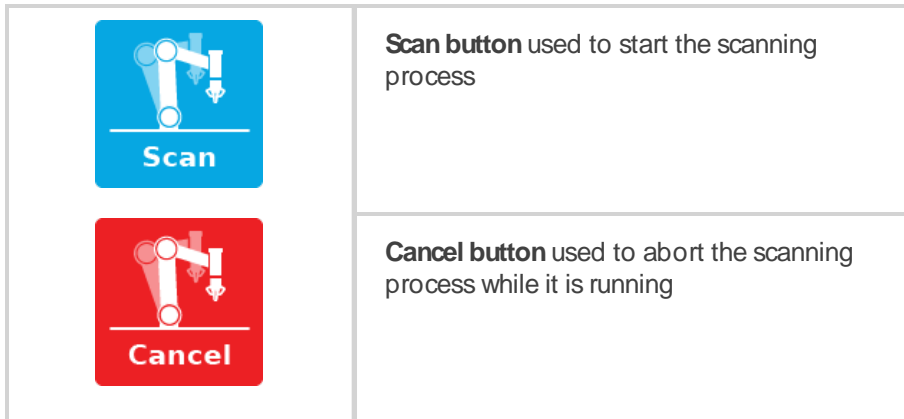

Fig. 7-26: Scan Model step with Scan button highlighted

The Vision System scans the object by taking 9 pictures.

When the process is completed, the wizard will bring up the **Configure Model** step. Please refer to the **Configuring the Model** for more information.

### 7.2.4. Parametric Method

When teaching a simple geometry object, it is recommended to use the **Parametric method**. It builds a model based on parameters of a basic 2D shape (circle, ring, square or rectangle). This method allows the vision system to recognize and locate with high robustness objects that have few distinctive features such as raw material blanks. It usually gives best results than the **Automatic method** for simple geometry and highly reflective objects.



Choose the geometry that corresponds to the object to detect and define its parameters:

- Circle
- Ring
- Rectangle
- Square

When using the Parametric method to teach an object, the Autopick functionality can accelerate building programs that use pick instructions. Autopick is only available to the Parametric method. For details, see section **Auto Pick** on page **105**.

#### Info

Height (h) is the distance between work plane and a 2D shape. It considers and compensates the thickness of the provided calibration board (~ 3mm) used to calibrate the work plane.

#### Caution

If you calibrated the work plane using a printed paper calibration board, add 3mm to height .



Define button used to confirm the dimensions of the object.

## Circle

Enter the circle diameter (D) and the height (h) at which the circle is located. Tap .

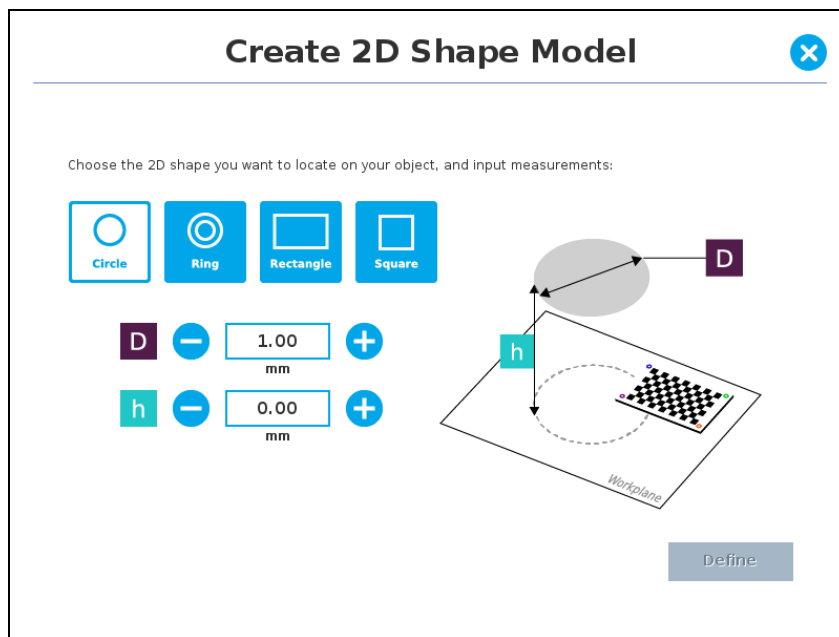

Fig. 7-27: Definition of a circle 2D shape.

## Ring

Enter the ring outer diameter (D), inner diameter (d) and the height (h) at which the ring is located. Tap the **Define** button.

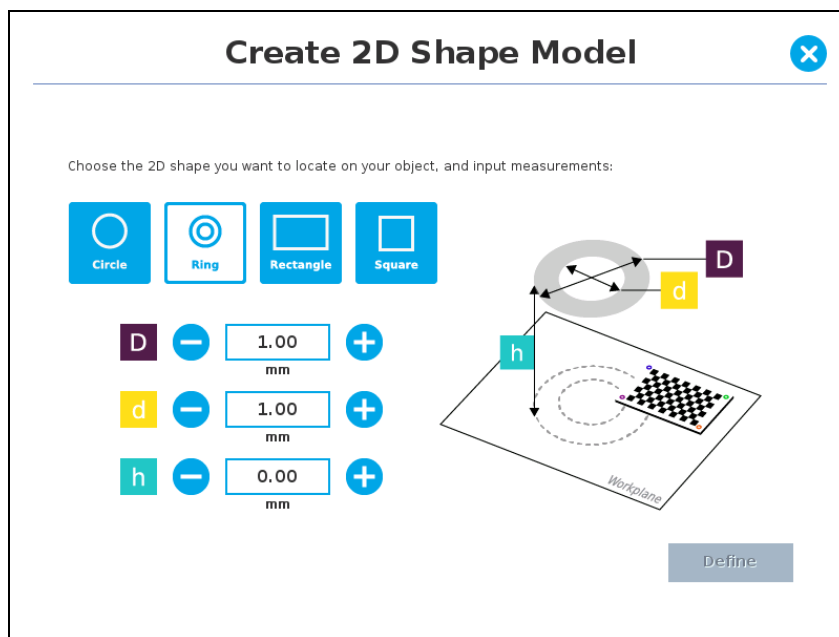

Fig. 7-28: Definition of a ring 2D shape.





## Rectangle

Enter the rectangle length (l), width (w) and the height (h) at which the rectangle is located. Tap the **Define** button.

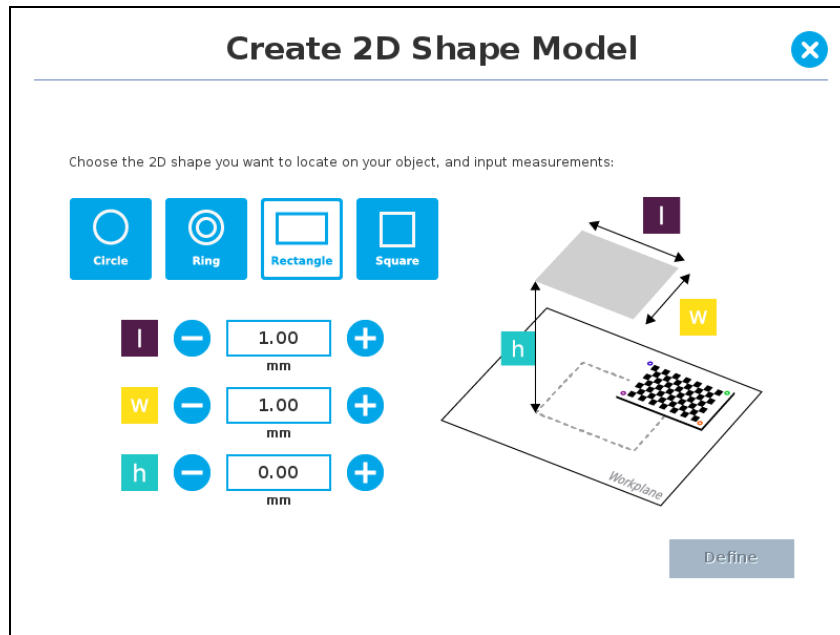

Fig. 7-29: Definition of a rectangle 2D shape.

## Square

Enter the square length (l) and the height (h) at which the square is located.

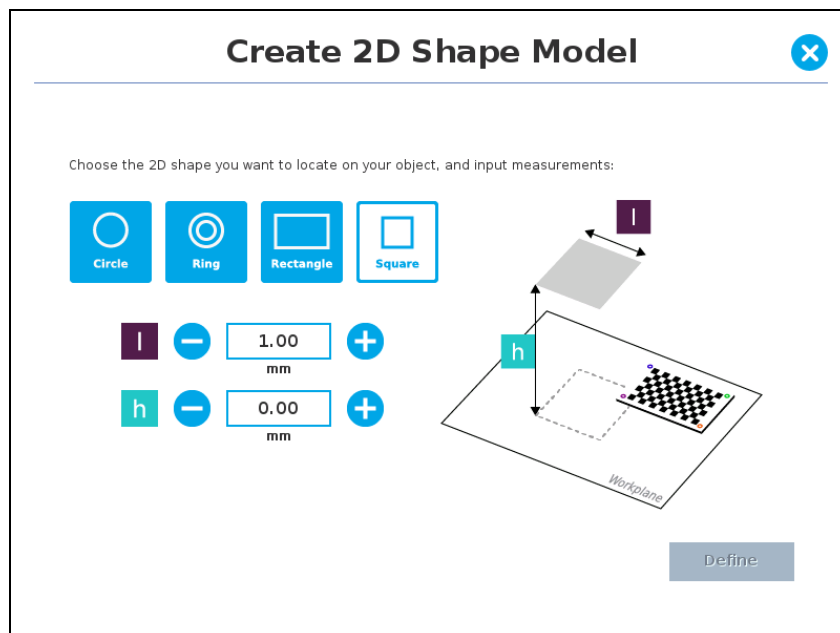







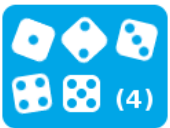





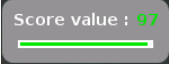





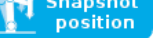

Fig. 7-30: Definition of a square 2D shape.

When the process is done, the wizard will switch to the Configure Model step. Please refer to the **Configuring the Model** for more details.

## 7.2.5. Configuring the Model

	<p>Test locating object button; the Vision System will search for the object in the field of view of the Wrist Camera.</p>
	<p>Back button; after testing an object's location, tap to return to the output image of the camera.</p>
	<p>Color validation button; tap to open the color validation menu.</p> <p>A color palette button with a red cross mark indicates that the color validation mode is not defined yet or disabled.</p>
	<p>A color palette button with a green check mark indicates that color validation was defined and is active.</p> <p>Please refer to the <b>Color Validation</b> for more details.</p>
	<p>Gripper Clearance Validation button; tap to open the Gripper Clearance Validation menu.</p> <p>A gripper button with a red cross mark indicates that the color validation mode has not been defined or has been disabled.</p>
	<p>A gripper button with a green check mark indicates that color validation was defined and is active.</p> <p>Please refer to the <b>Gripper Clearance Validation</b> for more details.</p>
	<p>Multiple ObjectDetection button; tap to open the multi-object detection menu and set the maximum number of objects to detect.</p>
	
	<p>Detection Threshold button; tap to expand the detection threshold menu. Please refer to the <b>Detection thresholds and scores</b> for more details.</p>
	<p>Minus button; tap to lower the value.</p>



	<p>Plus button; tap to increase the value.</p>
	<p>Camera settings button; please refer to the <b>Camera settings</b> for more details.</p>
	<p>Score value box; display section in which the detection score appears after testing the object location.</p>
	<p>Object location button; when an object is found, tap this button to view its position relative to the robot base.</p>
	<p>Set reference position button; tap to save the object's position for programming linear move (MoveL) relative to the object's location. Please refer to the <b>Save location</b> for more details.</p>
	<p>Save &amp; finish button; tap to save the detection threshold, the reference position and finish the wizard.</p>
	<p>Test/ Modify button; accessible via the Command tab of the Program Robot interface in Polyscope, once the object teaching wizard is completed.</p> <p>Tap to access the Test and Modify wizard. It allows the user to modify the detection threshold and the saved object position.</p>
	<p>Set position button; accessible via the Command tab of the Program Robot interface in Polyscope, once the Teach object wizard is completed.</p> <p>Tap to re-define a new reference position for the programming linear move (MoveL) relative to the object's location.</p>
	<p>Snapshot position button; accessible via the Command tab of the Program Robot interface in Polyscope, once the Teach object wizard is completed.</p> <p>Press and hold the Move button to move the camera directly to the Snapshot position .</p> <p>When grayed out, it indicates that the camera is at the Snapshot position.</p>
	<p>Ignore snapshot position button; accessible via the Command tab of the Program Robot interface in Polyscope, once the Teach object wizard is completed.</p> <p>When selecting Test/ Edit CamLocate node under the Command tab, if Camera is not at Snapshot Position, you either Move there OR stay and Ignore snapshot position.</p>



Reset button; accessible via the Command tab of the Program Robot interface in PolyScope, once the Teach object wizard is completed. Tap to reset the whole process of the object teaching wizard.



## Detecting Multiple Objects

From the "Configure Model" window, tap .

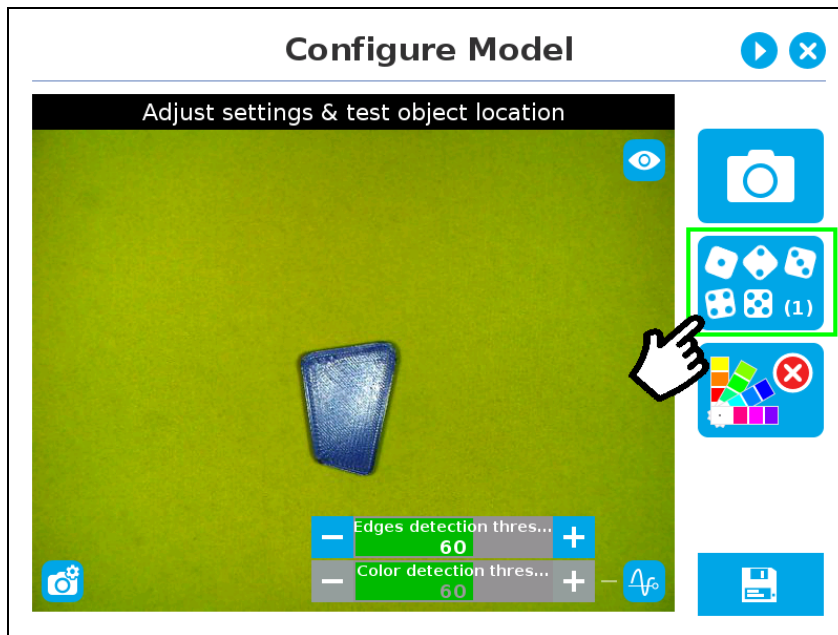

Fig. 7-31: Configure Model with multi-object button highlighted.

Once in the multi-object menu, tap the plus (+) symbol to increase the maximum number of objects to detect, or tap the minus (-) symbol to reduce that number.

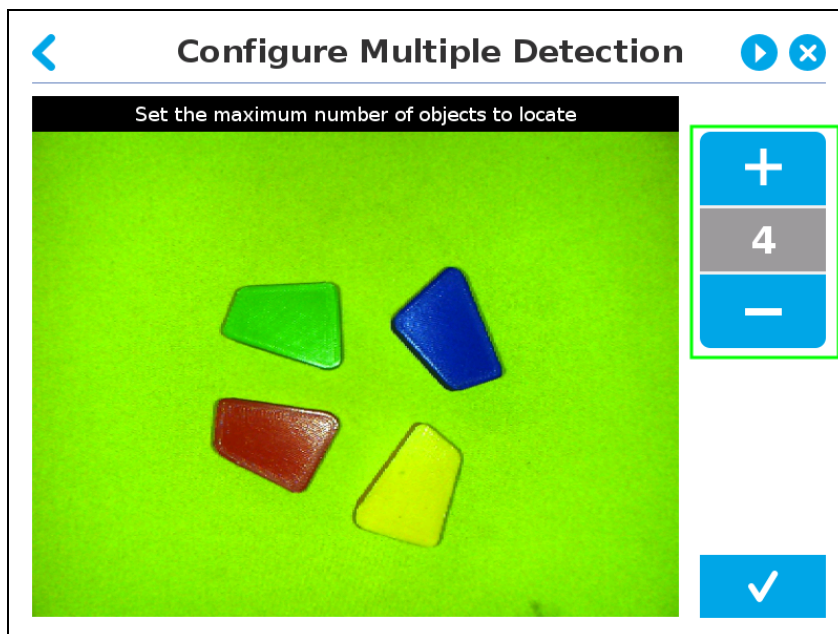

Fig. 7-32: Configure Multiple Detection menu.

## Color Validation

Color validation adds reliability to the Cam Locate functionality.

Whereas editing the model allows to select, configure and save the shape, outline and area of the model, the color validation allows the system to save the color signature of objects or features.

### Warning

Color validation is not intended for discriminating between two colors in the same Camera Locate node, no matter what the purpose is. However, this action can be performed and programmed with two or more Camera Locate nodes in the same program tree.

Color validation is not intended for eliminating all colors but one in a Camera Locate node, no matter what the purpose is.

### Automatic method

1. Tap the color validation button to access the color validation menu.

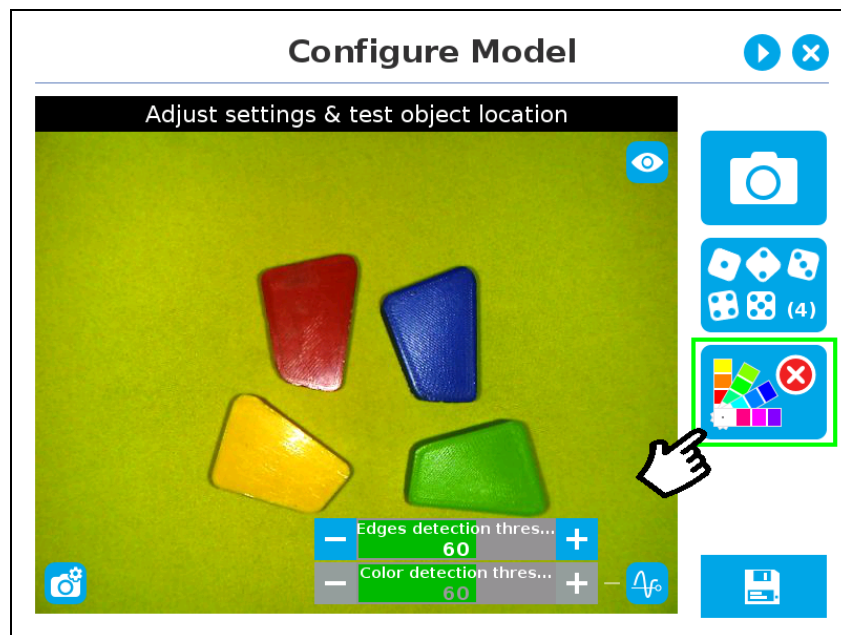

Fig. 7-33: Configure Model with color validation button highlighted.

2. Turn on color validation by tapping the red button on the right side of the screen.



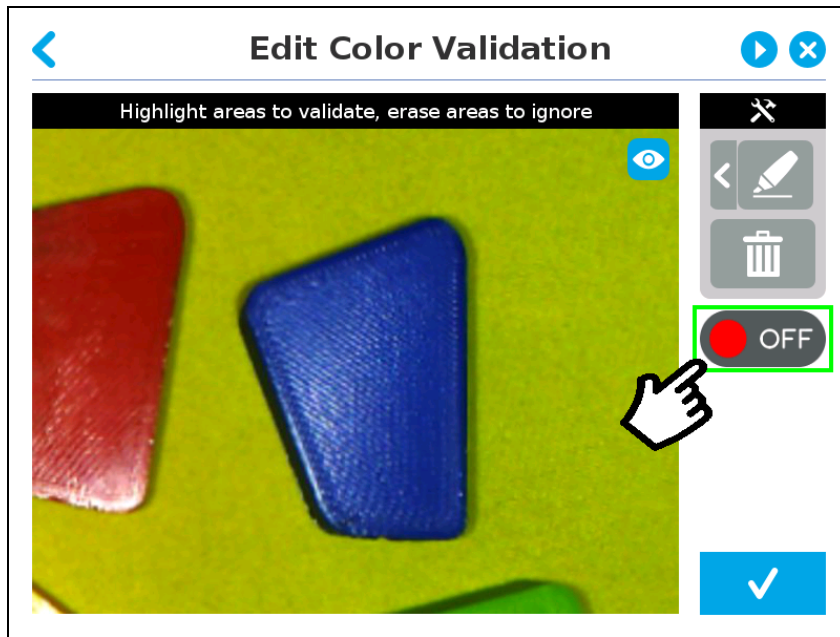

Fig. 7-34: Configure Model Color model with ON/OFF button highlighted

### Color sampling tools

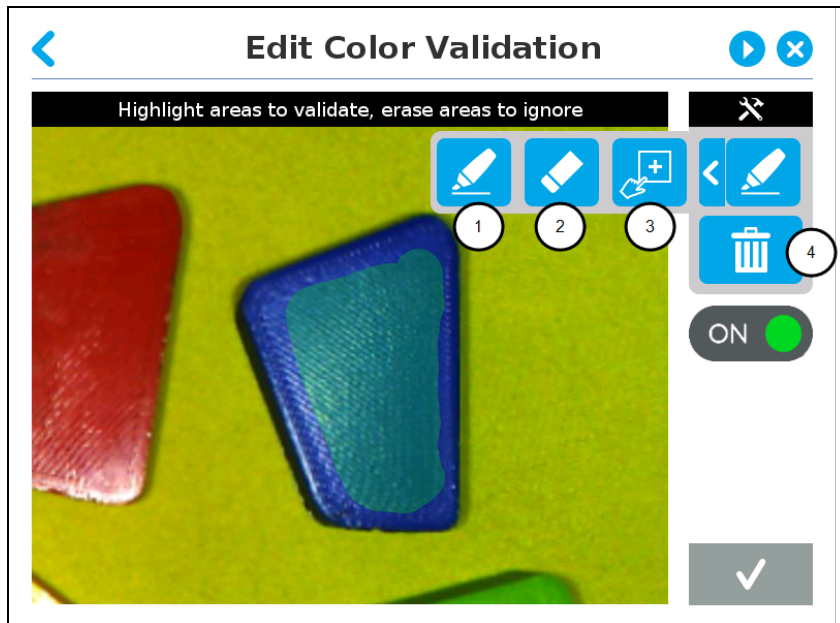

Fig. 7-35: Edit Color Validation with color sampling tools expanded

#### 1. Marker

The marker tool can be used to highlight features and edges to **include and keep** in the color sampling area.

Slide your finger or pointing device on the desired area(s) on the teach pendant. A green layer mask will be applied to the highlighted portion of the model.

#### 2. Eraser

The eraser tool can be used to ignore features and edges in the color sampling area.

Slide your finger or pointing device on the undesired area(s) on the teach pendant.

3. **Rectangle+** (add area)

The rectangle+ (add area) tool can be used to quickly highlight desired areas for color sampling.

Tap and drag your finger or pointing device to draw rectangular shapes that will highlight available features.

4. Garbage can

Tapping the garbage can icon will clear the object layer mask, thus deleting the selection area.

**Info**

The validation routine of the camera is performed in two steps:

1. Contour (edge) validation, with its own detection score
2. Color validation (if applicable), with its own detection score

**Tip**

Using the color validation helps to avoid false detections in your background.



Fig. 7-36: Examples of Edges Score for (a) a blue part (b) a red part.

**Parametric method**

1. Tap the color validation button to access the color validation menu.

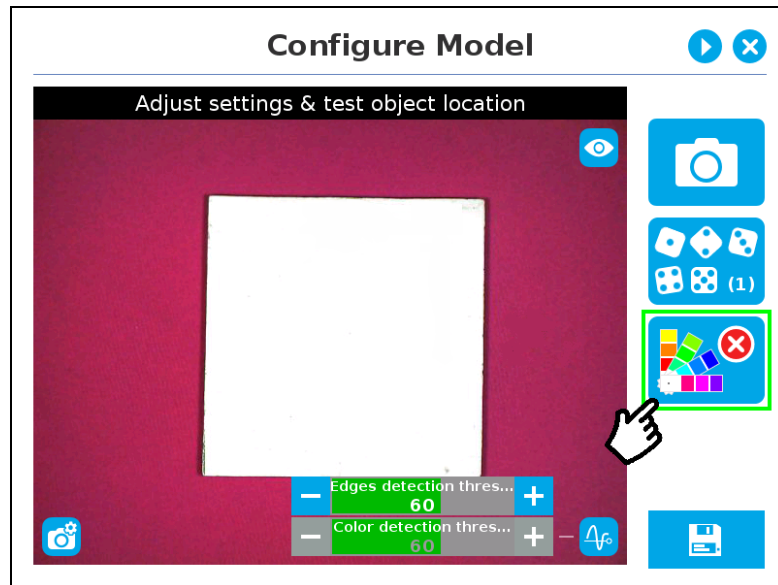

Fig. 7-37: Configure Model Step (Parametric method) with color validation button highlighted.





2. Turn on color validation by tapping the red button on the right side of the screen.

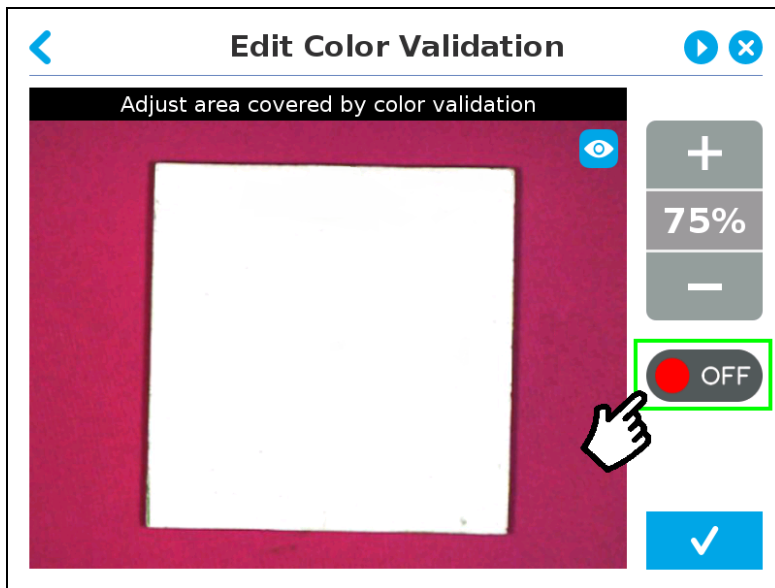
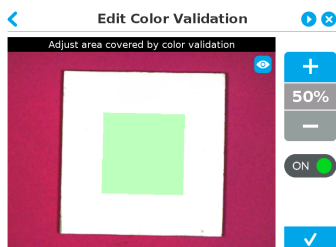

Fig. 7-38: Edit Color Validation menu (Parametric method) with ON/OFF toggle button highlighted.

### Color sampling tool

In the parametric method, given the inherent symmetry of the objects located by the system, color validation is supported via an expendable/shrinkable color selection zone, on par with the contour of the object to be located.

Tap the plus icon to expand the color selection zone, and tap the minus button to shrink the selection zone.



Color selection zone (50% of object size)

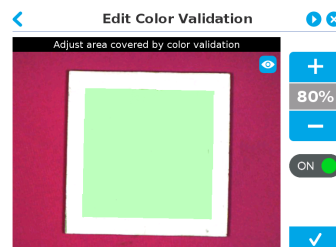

Color selection zone (80% of object size)

Fig. 7-39: Color selection zone (a) 50% of object size (b) 80% of object size

#### Caution

The size of the color selection zone ranges from 50% of the object size to 150% of the object size.

## Detection thresholds and scores

At the Configure model step, the user can tap the Detection threshold button in the lower right corner to expand the detection threshold settings.

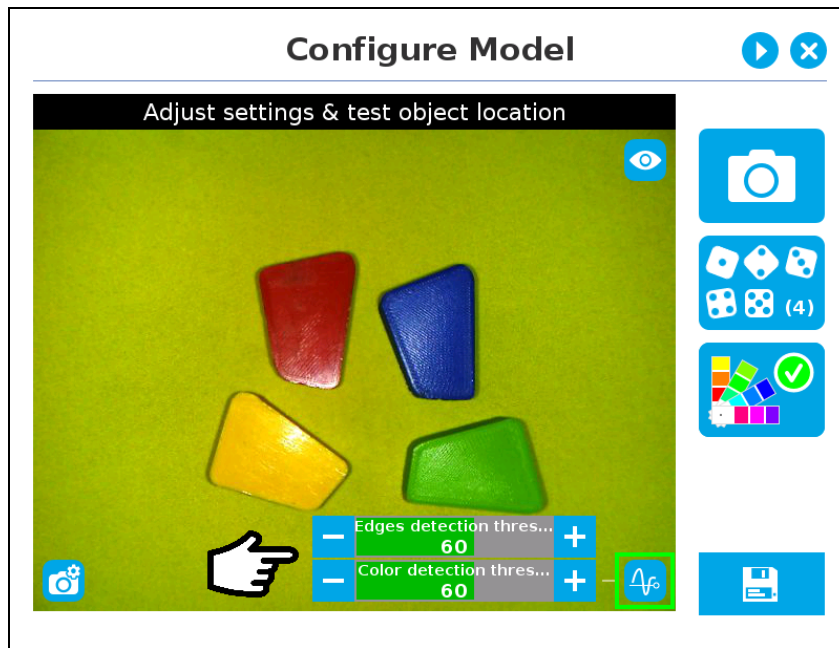

Fig. 7-40: Configure Model Step with detection thresholds highlighted.

After adjusting the detection thresholds, if applicable, the user can test the location of the object(s) in the field of view by tapping the camera icon.

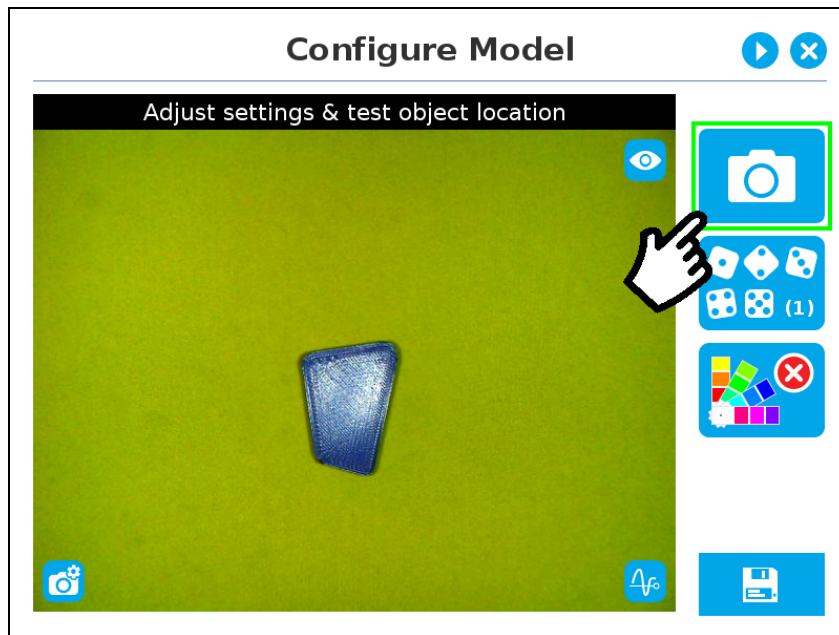

Fig. 7-41: Configure Model Step with camera icon highlighted.

### Info

In the context of multiple objects detection, each object detected has its own set of detection score values (%).



## Edges detection threshold and score

If the object is found, you will see the object outlined, surrounded by a blue rectangle, with the detection score value (%). If no object is found, an error message will display, reading that the object was not found.

Other objects detected will be surrounded by a white rectangle. Tap the other object(s) to display their own set of detection score values.

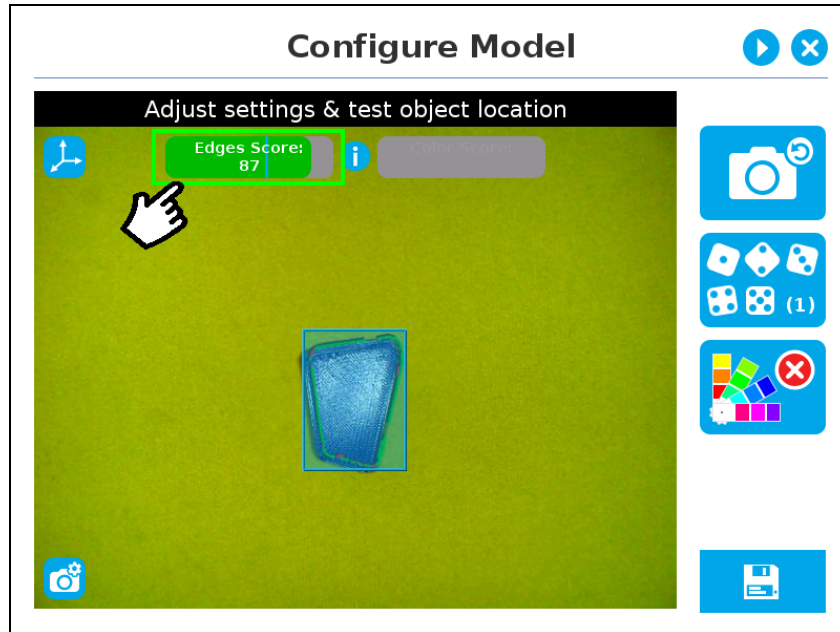

Fig. 7-42: Object found with detection score.

When testing the object(s) locating, object contours and detected features are outlined in green, while features that cannot be located within the field of view of the Wrist Camera are outline in red. Features from the model that cannot be located on the object in the field of view of the camera are outlined in red.

### Info

In the context of multiple objects detection, each object detected has its own set of detection score values (%). When performing the localization test, place the whole object over the workplane. Due to the perspective effect, some or all of the object features might not be recognized. If an important feature needs to be found for your application (a hole for example), make sure it is found during all localization tests. Again, green contour should match the object outlines at all times.

### Tip

How to prevent false positives: To avoid false detections, remove the object from the workplane, decrease the detection threshold to 0% and try to locate the object. If a false detection occurs on your workplane, you will see an object detected with the detection score. Increase the detection threshold above this score to avoid false detection.

- Try all areas of the workplane on which the object might be found. Adjust the detection threshold properly for the object and for the runtime environment.
- Adjust the detection threshold with the plus (+) and minus (-) buttons.

### Tip

Set the detection threshold at the highest value possible so the vision system detects the object on the whole workplane. Tap the **Test locating object** button to test the threshold.

This ensures optimal robustness for object detection everywhere on the workplane. If it is not possible to reach such a success rate, the following should be considered:

- Redefine the Cam Locate node (go through the Teach object wizard again), make sure there are no reflections, or as few as possible.
- Refer to the **Guidelines on Object Teaching** for instructions.

### Tip

After completing the object teaching wizard, it is possible to edit the detection threshold. To do so, select the Camera Locate node and go to the Command tab. Click on **Test/Modify** to edit the threshold and/or modify the position of the object.

## Color Detection Threshold and Score

Color detection can only happen following a successful edge detection.

### Caution

Color validation must be enabled in order to go through the color detection step. Please refer to the **Color Validation** for more details on enabling color validation.

If the object goes through the 2-step detection successfully, you will see the object(s) outlined, surrounded by a blue rectangle, with the detection score values (%).

Other objects detected will be surrounded by a white rectangle. Tap the other object(s) to display their own set of detection score values.



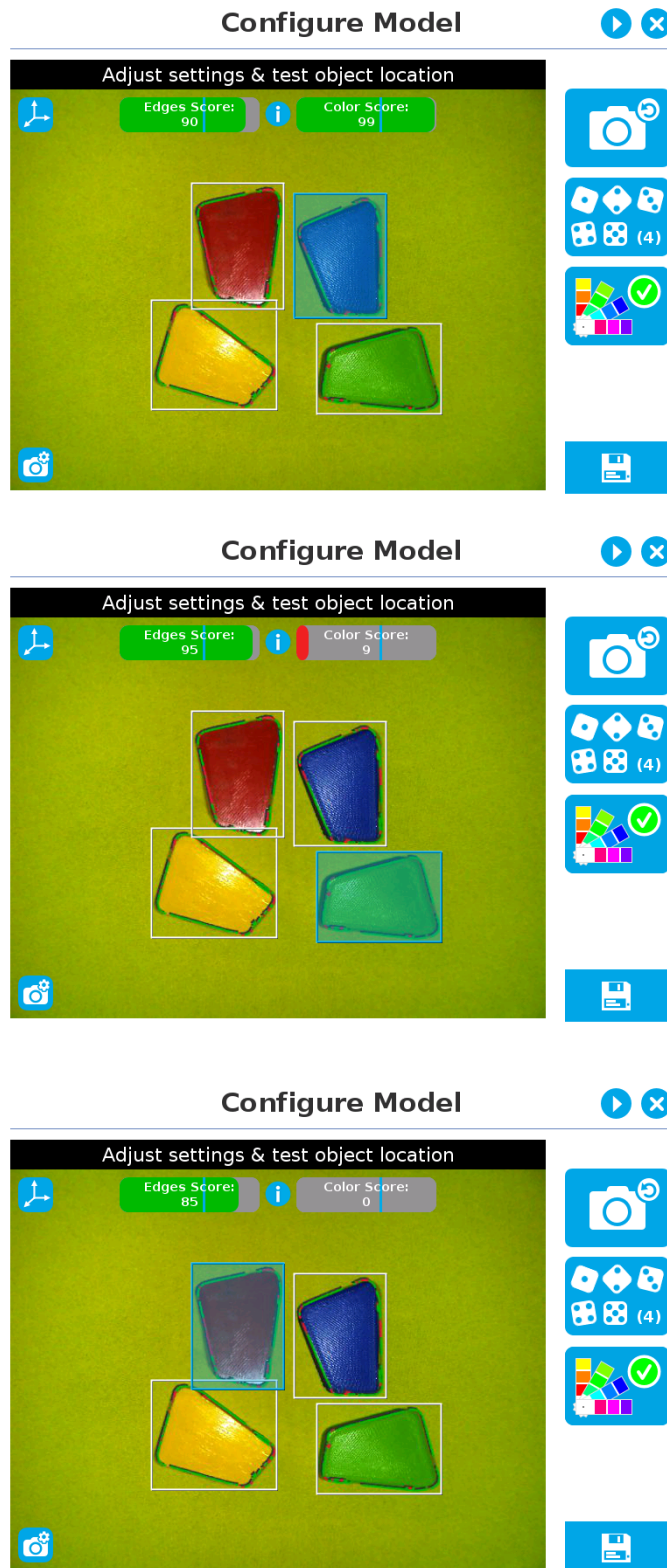

Fig. 7-43: Multiple objects found each with their selection rectangles and detection scores.

### Info

In the context of multiple objects detection, each object detected has its own set of detection score values (%).

## Gripper Clearance Validation

The Gripper Clearance Validation feature detects parts to avoid unwanted collisions between gripper and parts.

### Warning

Gripper Clearance Validation applies to objects of the same model based on identical detection criteria. Other models or objects present in the picture will be disregarded.

### Info

To set up Gripper Clearance Validation, you can align objects horizontally. This will optimize conditions for zooming and drawing the area, which in turn will speed up the process.

Set up gripper clearance validation using either the Automatic or the Parametric methods.

### Caution

Objects and their corresponding areas should be fully displayed on screen. Otherwise, they cannot be modified.

## Validation methods

### Automatic method

### Info

The Automatic method is only available when the model is defined with the automatic teaching method.

1. Tap the **Gripper Clearance Validation** button

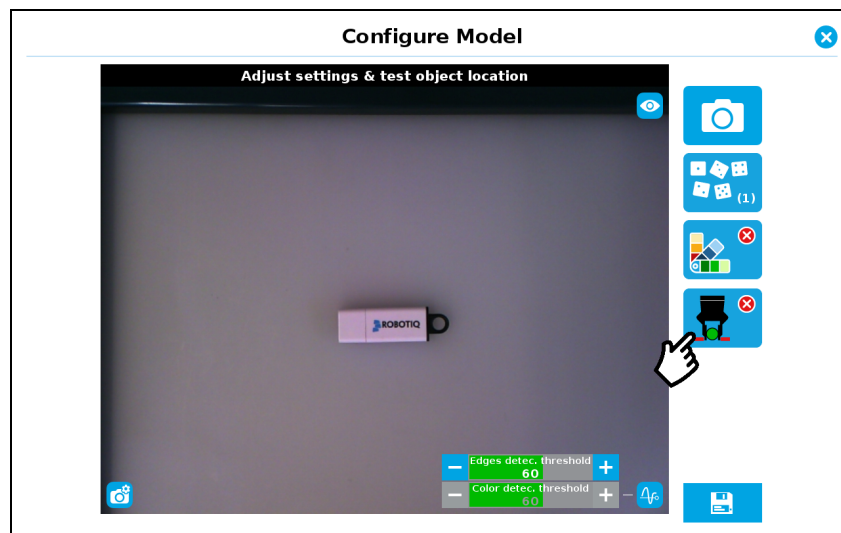

Fig. 7-44: Configure Model with Gripper Clearance Validation button highlighted.

2. To toggle Clearance Validation, tap the red button on the right side of the screen.



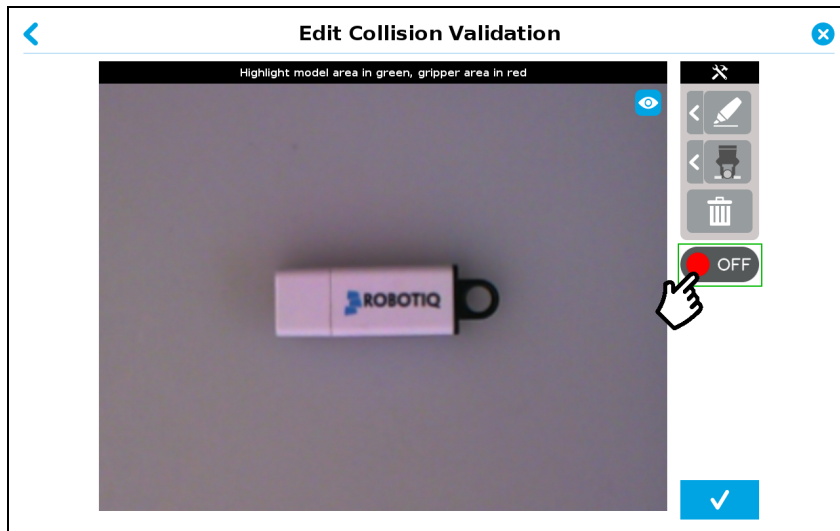

Fig. 7-45: Edit Collision Validation with ON/OFF button highlighted

- Adjust the clearance area with the available tools and tap the checkmark button to confirm the model and collision areas shown on screen. For more details about the gripper clearance samplings tools, please refer to the following section.

### Gripper Clearance Sampling Tools

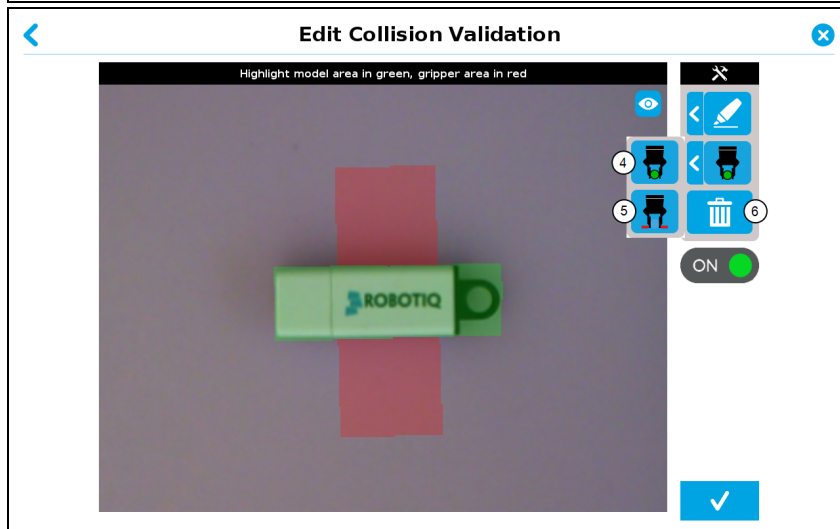
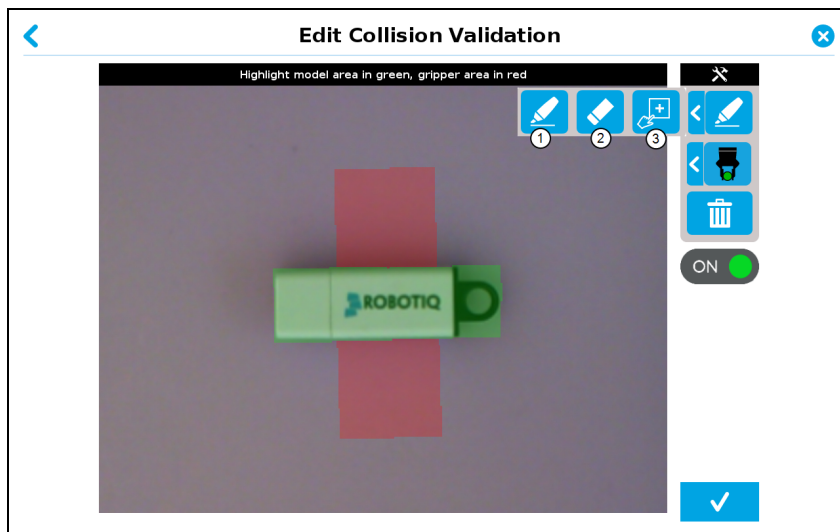

Fig. 7-46: Edit Collision Validation with Gripper Clearance sampling tools expanded.

1. **Marker**

The Marker tool highlights which features and edges to include in the object detection process. It can also be used to draw the clearance area for collision detection purposes.

Slide your finger or pointing device on the desired area(s) on the teach pendant. Toggle between object/collision detection by selecting either the Model Area (object detection) or Gripper Area (collision detection) buttons.

2. **Eraser**

The Eraser tool can be used to ignore features, edges and clearance area in selection area.

Slide your finger or pointing device on the undesired area(s) on the teach pendant.

3. **Rectangle+** (add area)

The Rectangle+ (add area) tool can be used to quickly highlight desired areas. This tool is extremely useful to define a rectangle for the gripper area.

Tap and drag your finger or pointing device to draw rectangular shapes that will highlight available features.

4. **Model area**

The Model area button adds or removes features and edges from the collision detection area. The selected area is shown as green on screen.

5. **Gripper area**

The Gripper area button adds or removes the clearance required for a gripper to pick up an object. The collision detection area is shown as red on screen.

6. **Garbage can**

Tapping the garbage can icon will clear the object layer masks, thus deleting the selection areas.

**Parametric method**

**Info**

The Parametric method is only available when the model is defined with the parametric teaching method.

1. To access the Gripper Clearance Validation menu, tap the **Gripper Clearance Validation** button.

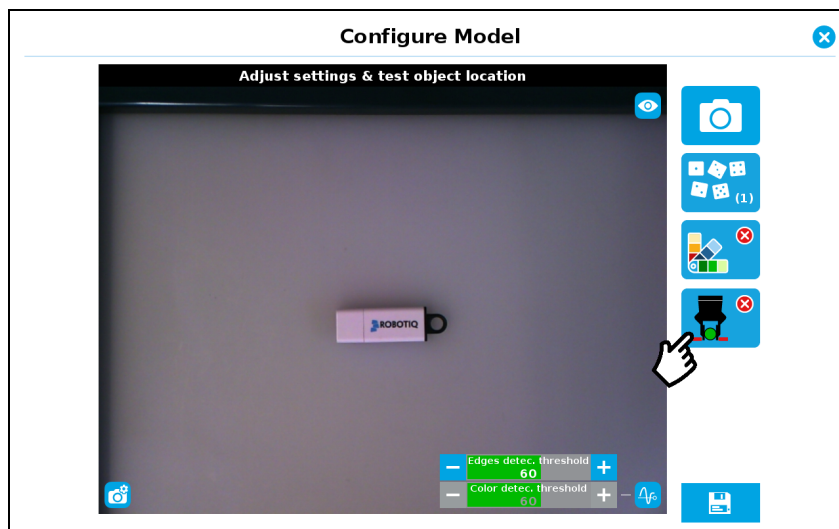

Fig. 7-47: Configure Model screen. The Gripper Clearance Validation button is highlighted.





2. To toggle Clearance Validation, tap the red button on the right side of the screen.



Fig. 7-48: Edit Collision Validation screen. Toggle button is highlighted.

3. Set the required clearance around the object using the plus and minus buttons.

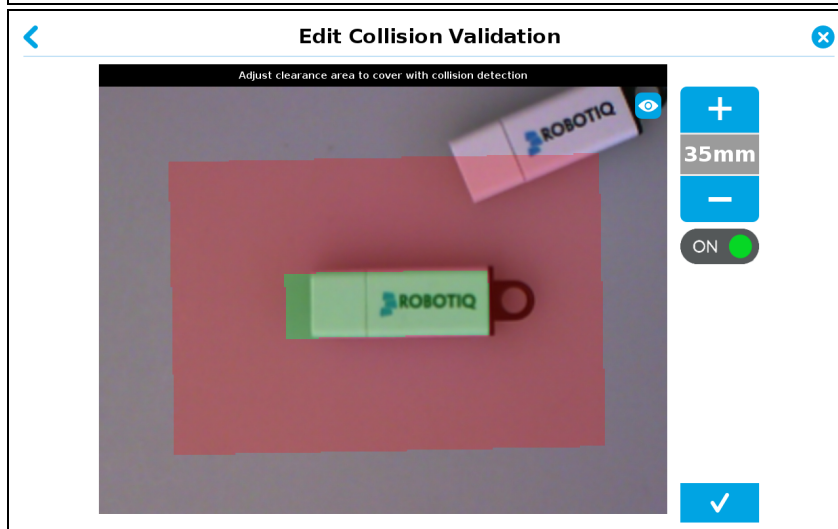
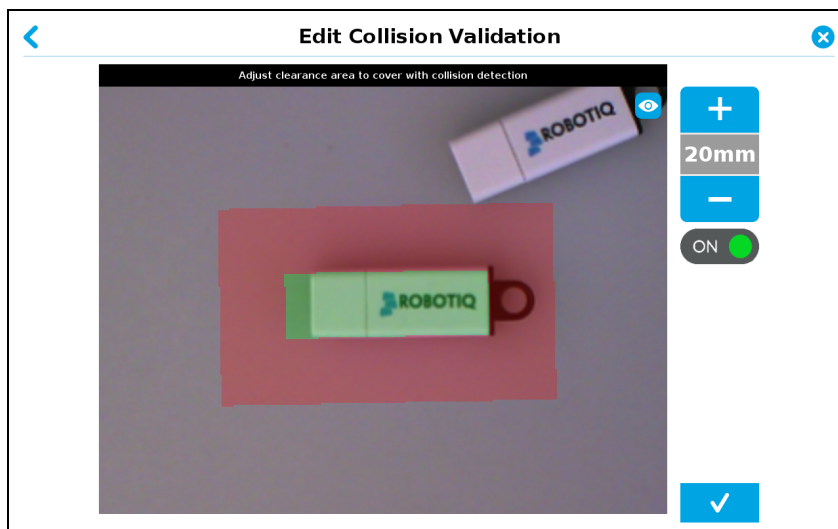

Fig. 7-49: Setting up the clearance perimeter.

4. Tap the checkmark button to confirm the model and collision areas shown on screen.

## Clearance verification

While the program is running, it is possible to see if there is enough clearance around the parts seen by the wrist camera. Here are the steps to follow to get this information.

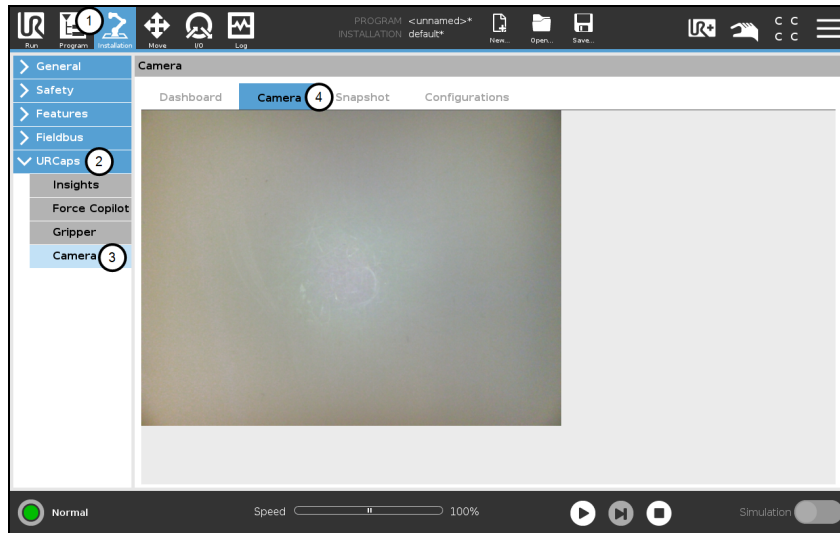

Fig. 7-50: Path to follow to have access to the clearance verification.

1. Tap on the **Installation** tab at the top of the screen
2. Select **URCaps** tab in the left pane of the screen
3. Select **Camera** menu
4. Once in Camera menu, tap **Camera** tab.

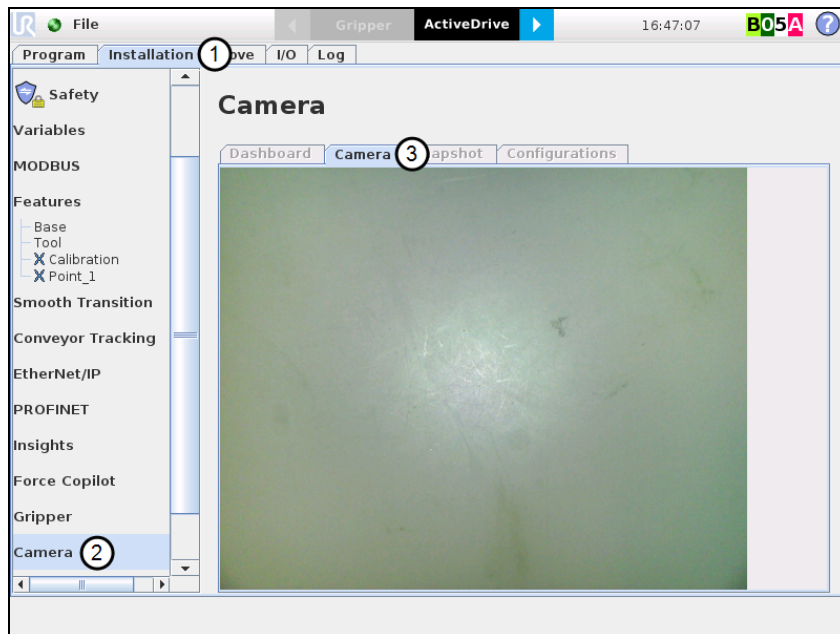

Fig. 7-51: Path to follow to have access to the clearance verification.

1. Tap on the **Installation** tab at the top of the screen
2. Select **Camera** tab in the left pane of the screen
3. Select **Camera** menu .

The gripper clearance statuses are now available as shown in the figure below.



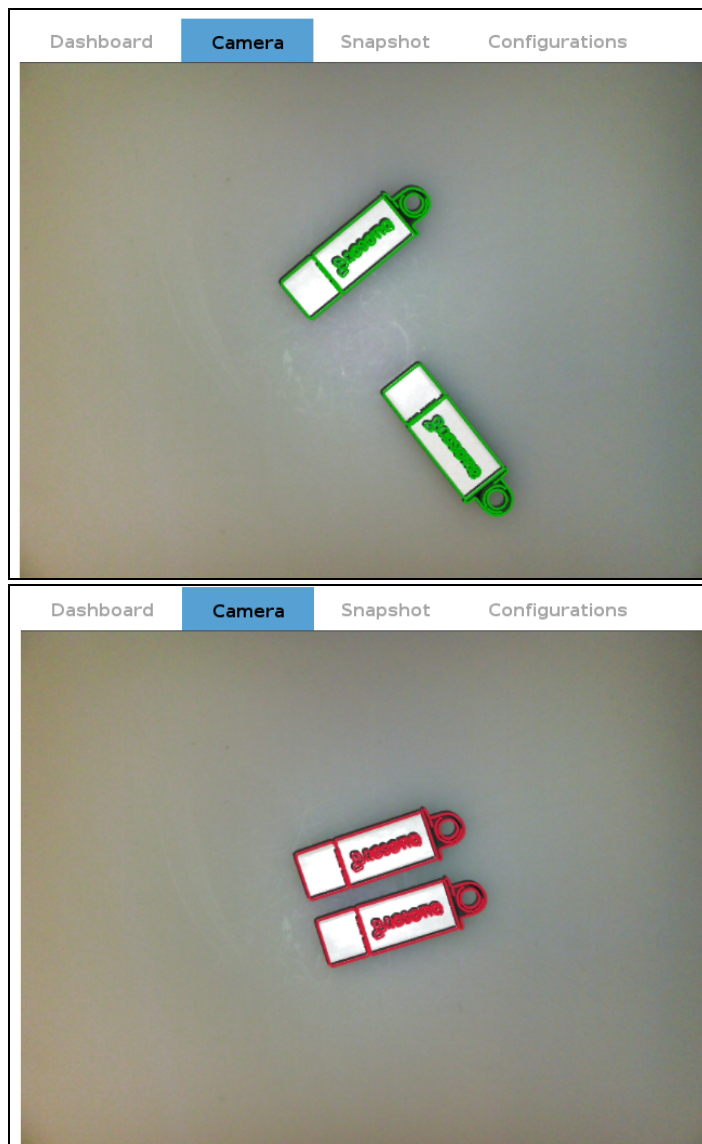

Fig. 7-52: Gripper clearance status while program is running.

## Camera settings

### Warning

Camera settings can be adjusted at the **Select Model** step of the Automatic teaching method **and/or** at the **Configure Model** step of the Teach object wizard.

Editing the camera settings at the Configure Model step will override the settings selected at the Select Model step of the Automatic teaching method.

Please refer to the **Object Teaching** for more details.

## Save location

Once you are done with the test and adjustment, tap the Set reference position button.

### Caution

Do not move the object after saving the position; the subsequent relative movements programmed will be relative to that position. Please refer to the **Cam Locate Node** for more details.

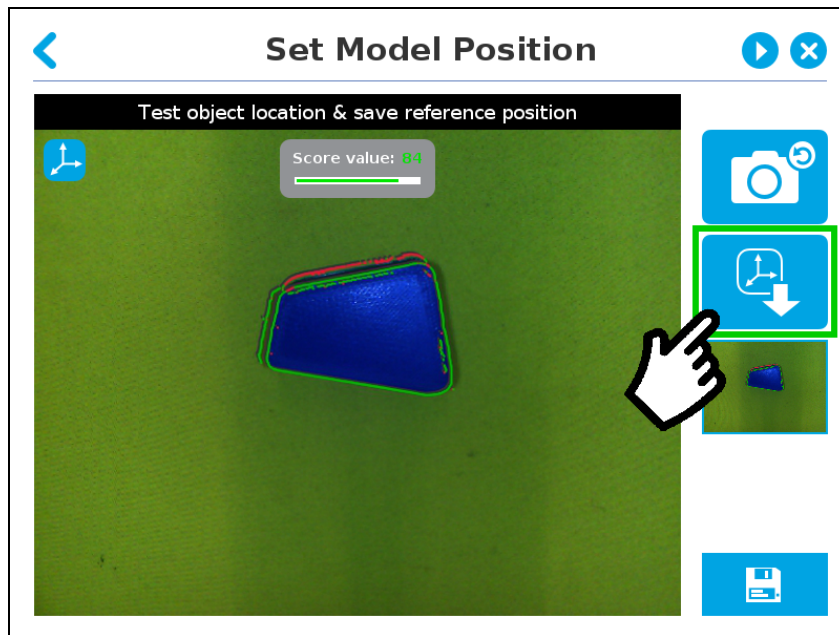

Fig. 7-53: Position defined.

Once the position is saved, tap the **Save & Reset** button in the lower right corner of the teach pendant interface.

When you are done with the teaching process, the Cam Locate node shows a snapshot of your saved object. You can tap **Reset** to redefine completely. You can tap **Test / Modify** to change the detection threshold or both the threshold and the saved object position.



---

# 8. Cam Locate Node

---

The Cam Locate node is used to teach objects. Once an object is taught through the Cam Locate node, you can use it to detect the object on a work plane, and to interact with it. See section **Object Teaching** on page 35 for a walkthrough.

## Programming

The first thing to do after completing the object teaching is to add a Move node to the snapshot position. When you exit the object teaching wizard, the robot arm is already in the Snapshot position location. You can simply add a MoveJ command before the Cam Locate node and set it to the location the robot arm is at (see Snapshot\_pos\_1 from the next figure).

### Caution

Make sure the robot arm is moved to the snapshot position before executing the Cam Locate node in the robot program.

The Cam Locate node acts as an "if" statement. If the taught object is detected by the camera, the robot program enters in the Cam Locate node and executes all command lines within it.

After teaching the object within the Cam Locate node, you may continue the programming by using either a linear move (MoveL) with the snapshot position variable as feature or the `object_location` pose. It is also possible to edit the detection threshold or the saved object position after the Teach Object wizard.

- See section **Linear Move with Feature** on page 96 to program a robot motion with a linear move (MoveL) with the snapshot position variable as feature. This allows to perform robot moves relative to the object detected at runtime.
- See section **object\_location pose** on page 97 to use an `object_location` pose with robot moves. For advanced users.
- See section **Edit Detection Threshold and Object Location** on page 100 to edit the detection threshold and/or the saved object position.

### Cycle Time

The Cam Locate node cycle time is influenced by background complexity, object complexity, and how many objects are on the work plane.

To reduce the Cam Locate cycle time, consider the following at runtime:

- Put fewer objects on the work plane.
- Limit number of object types.
- If your object has many detailed features, you can teach a drawing of it with simplified features or teach only one area of the object.
- Use diffuse lighting, avoiding high light intensity spots on the work plane.

## Enabling Fast Cycle Time

If ambient lighting is stable at runtime, you can enable the fast cycle time configuration. Go to the Installation tab > Camera > Configurations, and select Enable fast cycle time.



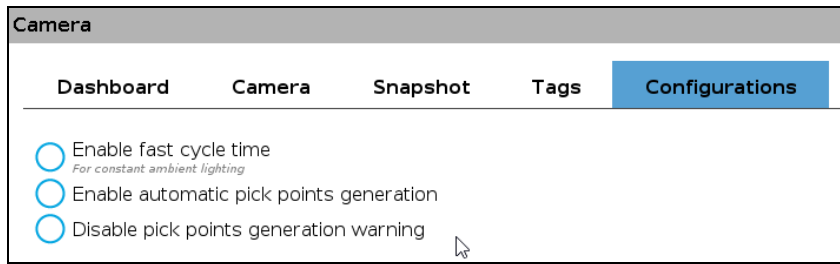

Fig. 8-1: To enable fast cycle time, ambient lighting must be constant.

By enabling the fast cycle time configuration, the camera exposure will be set the first time the program enters a Cam Locate node – at runtime. For others Cam Locatenodes, the Vision System retains exposure settings used in the first run. Enabling this option halves cycle time.

Fast cycle time	Behaviour of the Vision System	Which to choose
Enabled	Exposure is set once for a first run, and reused in following runs.	Halves cycle time. Ambient lighting must be stable.
Disabled	Exposure must be set at every run.	More robust part detection under variable lighting conditions.

Table 8-1: Fast cycle time configuration.

### Fast Cycle Time

Enable the fast cycle time configuration **only if the external ambient lighting is stable**.

## 8.1 Programming a Cam Locate Loop

When you insert a Cam Locate node, it automatically insert If/Else nodes, labelled as "For object(s) found)" and "If no object found" in your robot program.

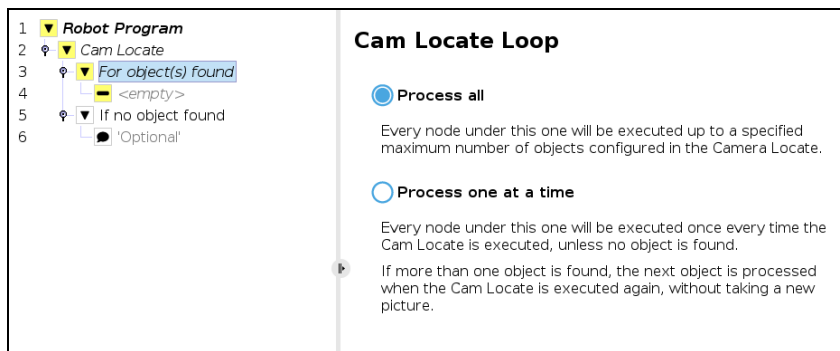

Fig. 8-2: Cam Locate Loop, "Process all" mode.

If you select the radio button Process one at a time from the "Cam Locate Loop" window, the node "For object(s) found" is renamed to "For next object".

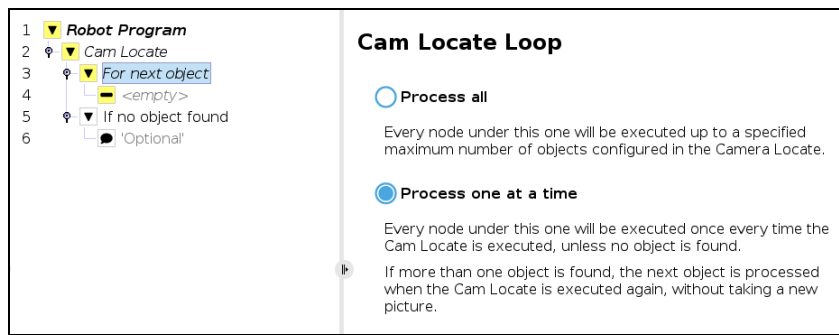

Fig. 8-3: Cam Locate Loop, "Process one at a time" mode.

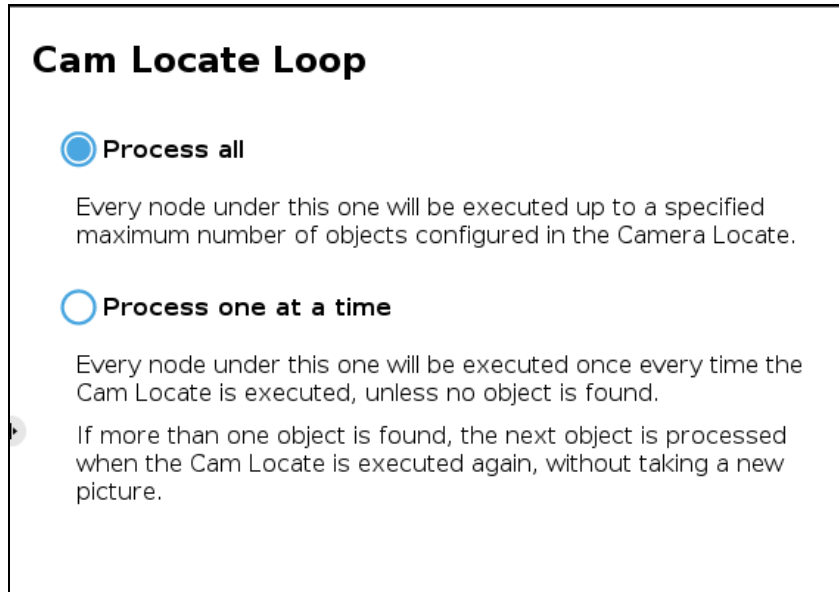

Fig. 8-4: The Cam Locate loop can operate on two different modes.

## 8.11. Process all

When this option is selected, the Wrist Camera takes one picture, and finds objects (their number can be changed when teaching the object). Then, the robot program will carry out instructions under "For object(s) found" for all objects that have been found, and finally, the Cam Locate Loop will be exited.

## 8.12. Process one at a time

When this option is selected, the Wrist Camera takes one picture, and finds objects (their number can be changed when teaching the object). Instructions under "For next object" are carried out only once, the robot program exits the loop, and continues. When the Cam Locate node is run once again, the robot program re-enters the loop, locating an object by using the picture that was first taken. When all objects from the picture have been processed, the Cam Locate instruction takes a new picture to find new objects.

## 8.2. Linear Move with Feature

Once the Teach Object wizard is completed, you saved the last position of your object. The object position variable, named after the snapshot position, now contains the reference frame of the object in this saved position. Each time the Camera Locate node localizes an object, it updates that feature variable's frame with the new detected object's position and orientation. That feature is named according to the feature name you chose during the snapshot position definition.



## Saved position

The saved object position from the Teach Object wizard or the Test/Save wizard is the position of the object to be used for the relative robot motion programming. Once the position is saved, do not move the object to ensure proper robot motion programming within the Camera Locate node.

You can use that reference feature inside the Camera Locate node within Move commands of the robot. To do so:

- Insert a Move node.
- In that node, go to the Command tab.
- Select MoveL.
- Select the appropriate feature (your Snapshot Position / Feature name).

Every waypoint inserted within that MoveL node will be relative to the feature updated by the Cam Locate

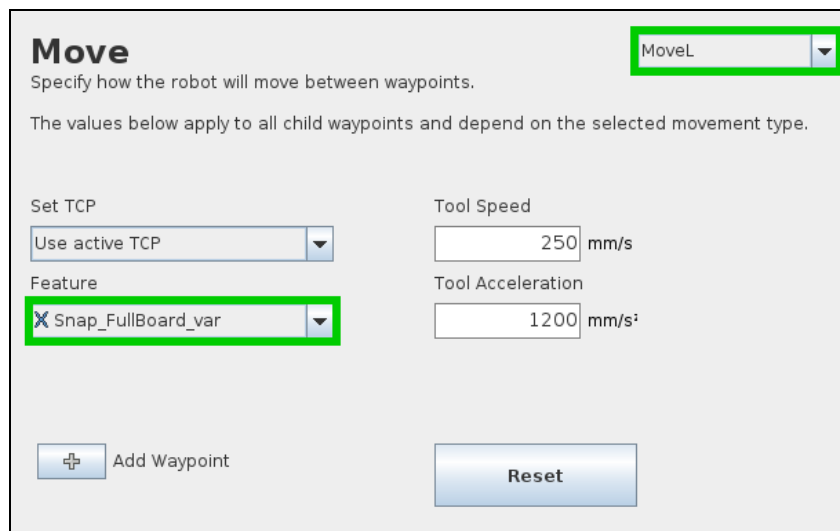

The screenshot shows the 'Move' configuration window for Universal Robots CB-Series models. The 'MoveL' movement type is selected in the top right dropdown. The 'Feature' dropdown is set to 'Snap\_FullBoard\_var'. The 'Tool Speed' is set to 250 mm/s and 'Tool Acceleration' is set to 1200 mm/s<sup>2</sup>. There are 'Add Waypoint' and 'Reset' buttons at the bottom.

Fig. 8-5: Inserting a Move node with Universal Robots, CB-Series models .

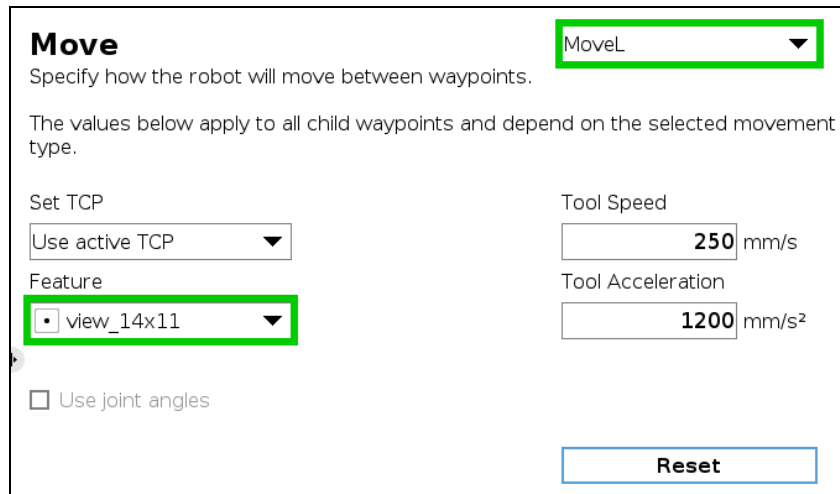

The screenshot shows the 'Move' configuration window for Universal Robots e-Series models. The 'MoveL' movement type is selected in the top right dropdown. The 'Feature' dropdown is set to 'view\_14x11'. The 'Tool Speed' is set to 250 mm/s and 'Tool Acceleration' is set to 1200 mm/s<sup>2</sup>. There is a 'Reset' button at the bottom.

Fig. 8-6: Inserting a Move node with Universal Robots, e-Series models .

## 8.3. object\_location pose

Once a snapshot position is defined, the work plane used for the calibration gets its own coordinate system, regardless of its orientation. This coordinate system is shown in the figure below.



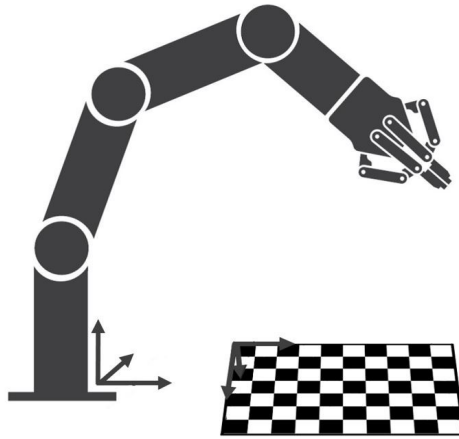

Fig. 8-7: Work plane reference frame.

The Wrist Camera detects an object on the workplane and find its X-Y position, as well as its Z-orientation in the work plane coordinates system (see Fig. 8-8). Thus, a detected object is always laid flat (parallel) to the work plane. It is possible to use the `object_location` pose, which is a variable containing the detected object pose [positions X, Y, Z, and rotations Rx, Ry, Rz] in the robot base reference frame. This variable is updated each time the program goes within a Cam Locate node, thus every time an object is detected, regardless of how many Cam Locate nodes are in the program. The `object_location` pose is relative to the robot base frame.

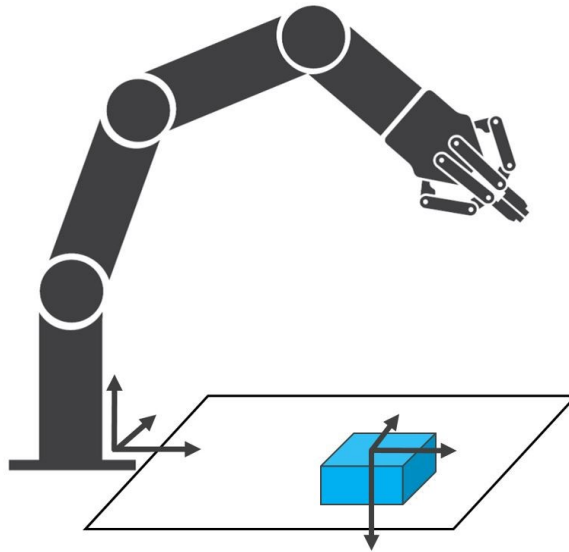

Fig. 8-8: `object_location` pose on the workplane used for the calibration.

**object\_location** is a variable with the pose structure (x, y, z, x rotation, y rotation, z rotation):

**x**: x position of the object detected, relative to the robot's base reference frame.

**y**: y position of the object detected, relative to the robot's base reference frame.

**z**: z position of the object detected, relative to the robot's base reference frame.

**x rotation**: x rotation from the robot's base frame to the detected object feature reference frame. The object's X axis is parallel to the workplane on which the calibration has been performed.

**y rotation**: y rotation from the robot's base frame to the detected object feature reference frame. The object's Y axis is parallel to the workplane on which the calibration has been performed.



**z rotation:** z rotation from the robot's base frame to the detected object feature reference frame. The object's Z axis is normal to the workplane on which the calibration has been performed, points downwards from it, into the workplane.

### Object\_location pose and TCP

If you move the robot's TCP to the object\_location pose, the TCP will go and point the object on the workplane. The height value of the object on the workplane should not be taken into account - the TCP might be directly on the object when moving it to the object\_location pose.

### Program Example

The program examples below show how to use the object\_location pose variable. The first one simply moves the robot so that the TCP goes directly on the detected object. Make sure the TCP is set properly to avoid collisions.

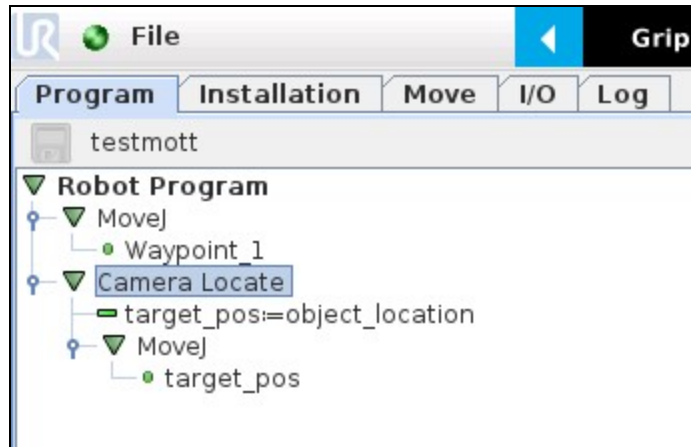

Fig. 8-9: Program example - place the TCP on the detected object. CB-Series robot program is illustrated.

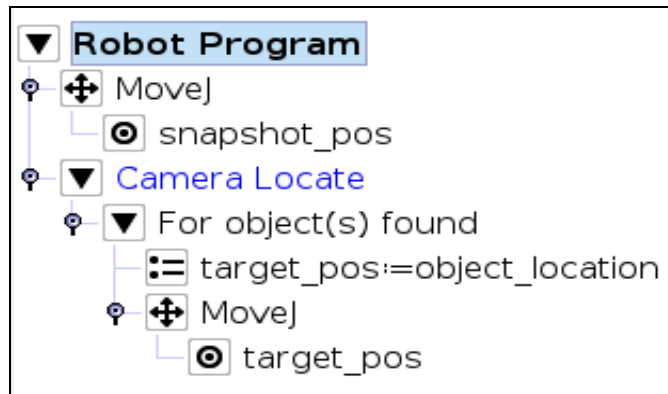

Fig. 8-10: Program example - place the TCP on the detected object. e-Series robot program is illustrated.

The second example moves the robot so that the TCP goes 20 cm above the detected object. This is in the case of an horizontal plane.

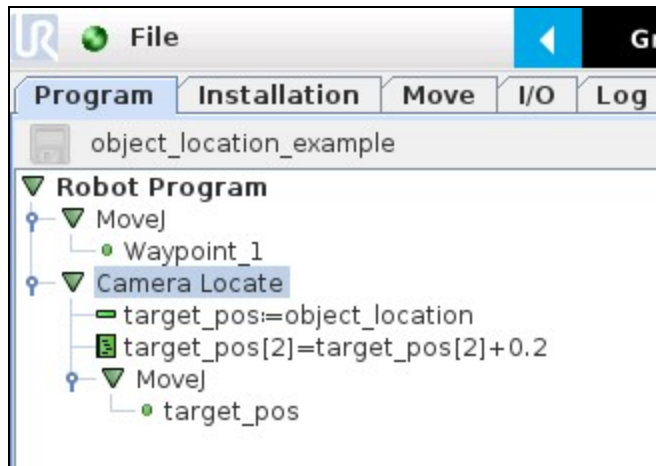

Fig. 8-11: Program example – Place the TCP 20 cm above the detected object, in case of an horizontal plane. CB-Series robot program is illustrated.

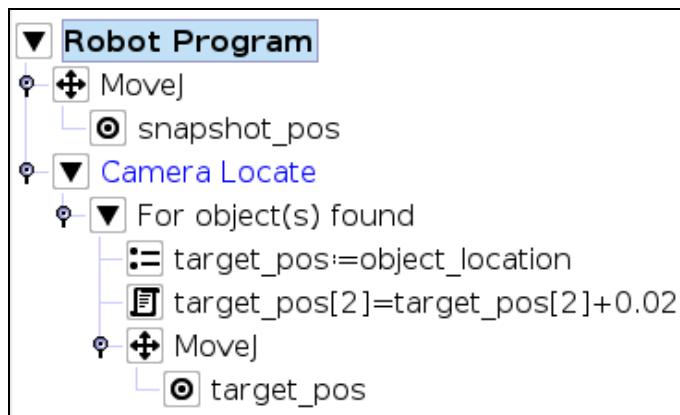

Fig. 8-12: Program example – Place the TCP 20 cm above the detected object, in case of an horizontal plane. e-Series robot program is illustrated.

### Info

A statement, called `If no object found` is also present to determine the action to do when Cam Locate does not find any object.



## 8.4. Edit Detection Threshold and Object Location

It is possible to edit both the detection threshold and the object location after the Teach object wizard has been completed. Tap Cam Locate > Command > Test/Modify (see Fig. 8-13).





Fig. 8-13: The taught object model can be viewed from the "Command" tab of a Cam Locate node.

- Objects can be retaught. To do so, tap . The "Configure Model" window is displayed.

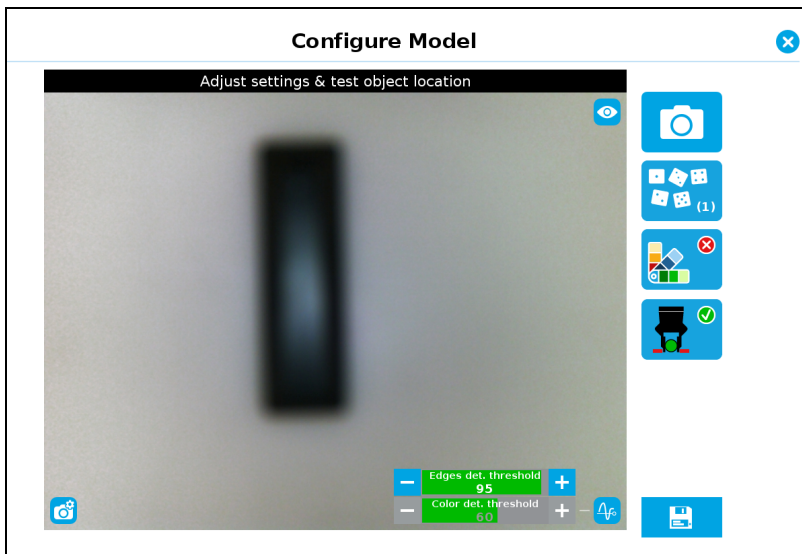

- Object position can be modified. To do so, tap . The "Modify Model Position" window is displayed.

Move object to its new position. To take the new picture, tap . To confirm this new position, tap . A warning message is displayed to prompt you to confirm this new position. To confirm, tap Define.

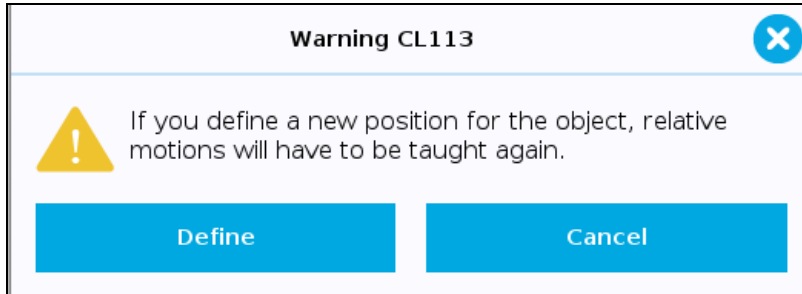

A thumbnail of the object appears under .

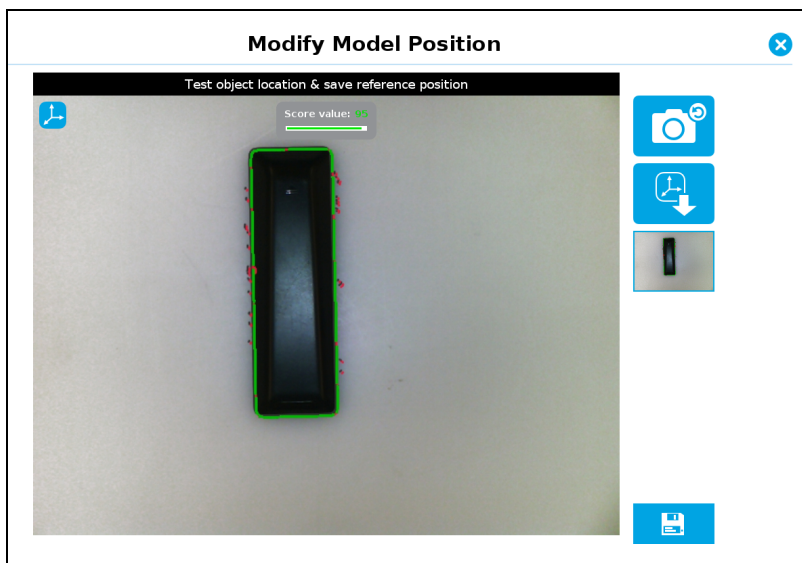



Tap  to exit the wizard.

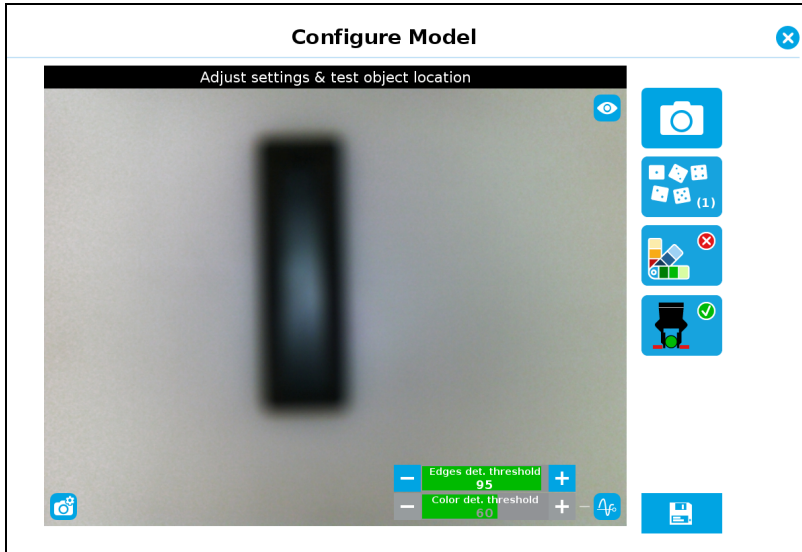

- To modify only the detection threshold, modify it and test it.



Once it is at the required value, tap . This does not modify the object position previously saved.

- To modify both the threshold and the object location, adjust the threshold, place the object in the desired position and test is with the Test locating object button. Once in the desired position, tap Define new position. The position is saved. Tap  to save the threshold.

## 8.5. Using a Variable Snapshot Position

During a robot program, the robot must be at the snapshot position before entering the Cam Locate node. If it is not in the right position, a pop-up will appear, preventing the camera from taking a snapshot from the wrong position. This is to ensure good precision since the workplane has been previously calibrated for this snapshot position.

In some cases, it is helpful to move the robot to a variable position to enter a Camera Locate node. For instance, it can also be used to teach only one snapshot position and object to manage parts in stacked trays. In order to do so, allow the robot to be in a different position that the original snapshot position by entering the script command:

```
ignore_snapshot_position = True
```

You also need to edit the `snapshot_position_offset` pose variable. This variable contains the pose offset between the original saved snapshot position and the one used in the program .

### Info

Please note that the arguments of the `snapshot_position_offset` parameter are expressed in the robot base reference frame.

The example shows a program using a Cam Locate node to manage parts in stacked trays.

- The script command in the BeforeStart section allows the camera not to be in the exact snapshot position when entering a Cam Locate node.
- The pose at which the robot enters the Cam Locatenode is calculated knowing how many trays are stacked.
- The `snapshot_position_offset` is calculated accordingly for the Wrist Camera to consider the pose offset from the original snapshot position.

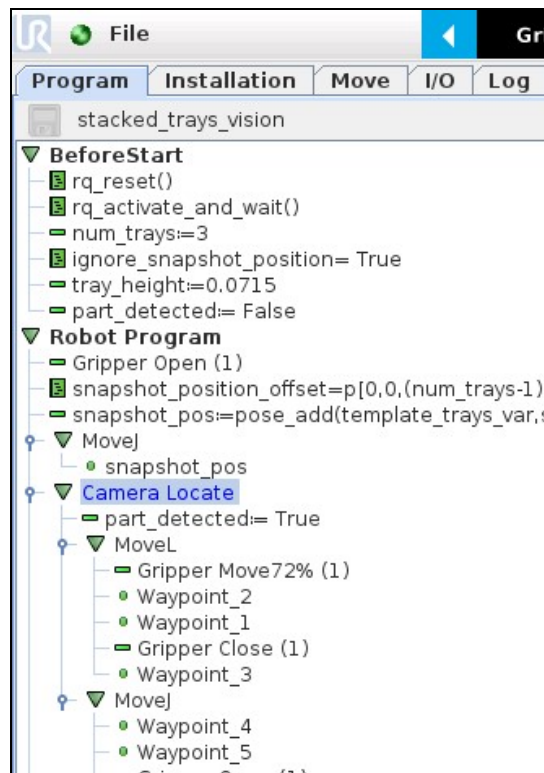

Fig. 8-14: Program example, using Universal Robots CB-Series models.

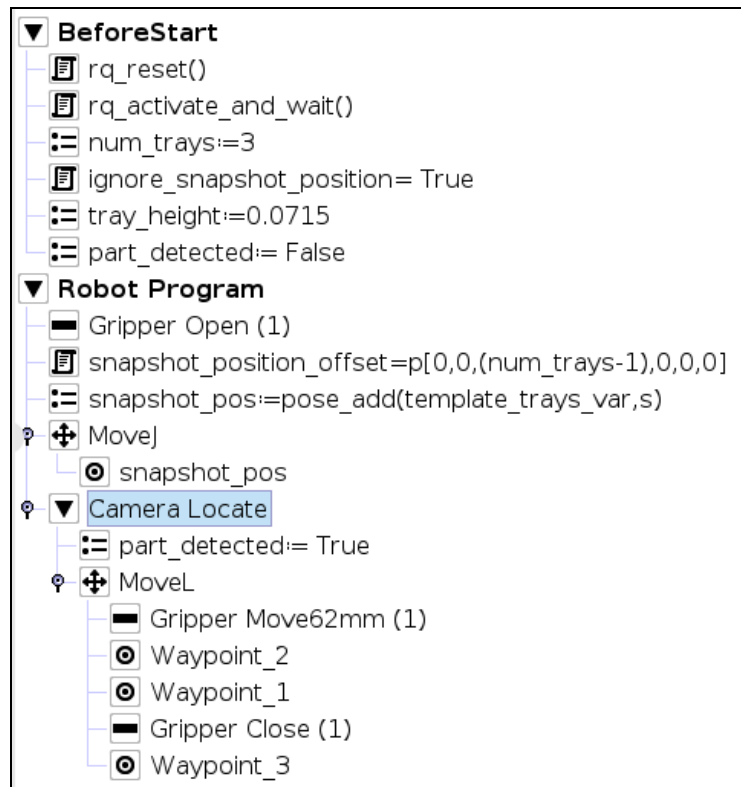

Fig. 8-15: Program example, using Universal Robots e-Series models.



```
ignore_snapshot_position = True
```

When using this method, make sure the workplane has the same orientation and distance regarding the position of the camera before a Cam Locate node. Using a variable and relative snapshot position may decrease the precision, as the workplane can be slightly different depending on where the calibration has been performed. Be aware of this when programming a Cam Locate node relative to another one.

## 8.6. Auto Pick

The Auto Pick functionality is available after teaching an object with the Parametric method, and is used to accelerate adding pick instructions.

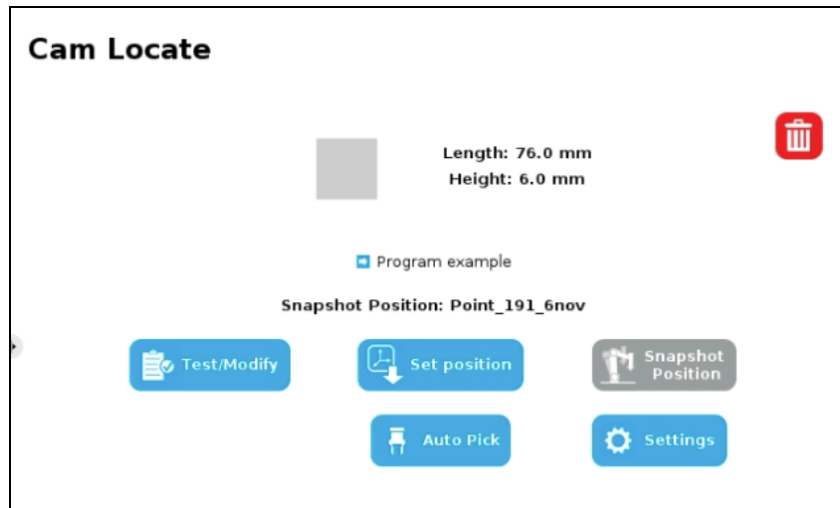



Fig. 8-16: The Auto Pick functionality becomes available after using an object using the Parametric method.

When you tap  **Auto Pick**, some nodes are inserted in your robot program under a MoveL node, as in the structure shown below:

- MoveL
  - Approach Point
  - Pick Point
  - Comment (" Insert pick action" )
  - Retract Point

Basically, Auto Pick inserts a MoveL node based on the values you entered in the Parametric method when teaching the object. The values of " Approach Point" and " Retract Point" are automatically inserted, and based on the values entered when teaching the object. However, these two nodes have independent values.

The approach point added via the Auto Pick button will be located over the object at its exact center. The distance between approach point and object center is calculated based on the TCP value entered in the Teach Pendant for your hardware setup.

Here is a general view of the Auto Pick functionality, and how it can be used in a robot program.



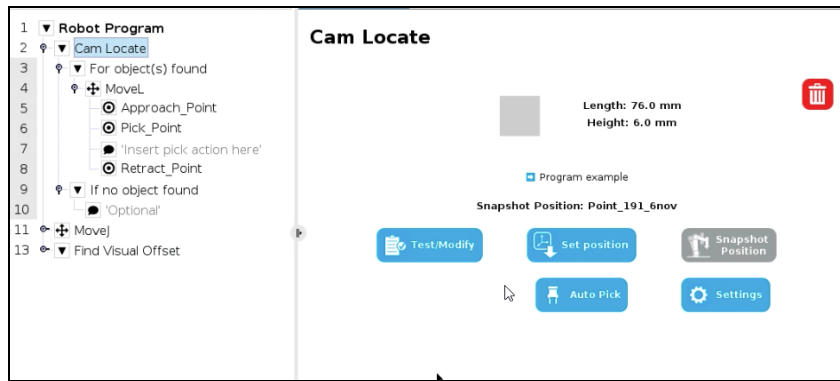

Fig. 8-17: This MoveL node was inserted using the Auto Pick button.

### Tip

For a smoother experience using Autopick, modify Teach Pendant options under Installation > URCaps > Camera > Configurations. Check the following radio buttons:

- " Enable automatic pick points generation"
- " Disable pick points generation warning"

## 8.7. Camera Locate Settings

You can configure a Cam Locate node using these options:

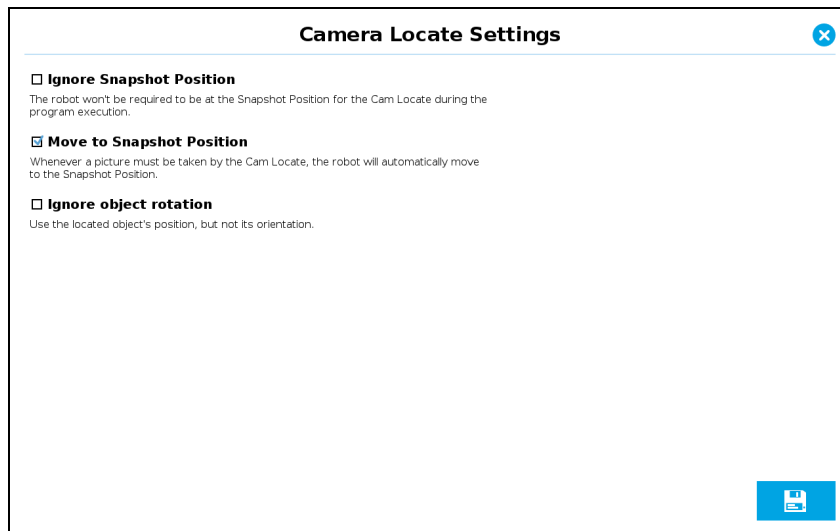

Fig. 8-18: Cam Locate node settings.

Option	Description
Ignore Snapshot Position	The robot won't be required to be at the Snapshot Position for the Cam Locate during the program execution.
Move to Snapshot Position	Whenever a picture must be taken by the Cam Locate, the robot will automatically move to the snapshot position.
Ignore object rotation	Use the located object's position, but not its orientation.



*Fig. 8-19: These options can be used to reduce cycle time or to improve part detection.*

### **Tips**

- Ignore Snapshot Position can reduce cycle time.
- Move to Snapshot Position can improve part detection.
- Ignore object rotation can reduce cycle time for round objects.
- Ignore Snapshot Position and Move to Snapshot Position are mutually exclusive.











---

## 9. Scan Code Node

---

### 9.1 Supported Types of Codes

The Scan Code node is used to read various types of barcodes and 2D codes (QR, Datamatrix, PDF417).

Code Image	Type
	Datamatrix
	QR
	PDF-417
	Code 93
	EAN-8
 0 123456 789012	EAN-13
 1234567890	ITF-14
 0 123456 5	UPC-E
 1 23456 78901 2	UPC-A
	Code 39
	Code 128



## 9.2. Guidelines on Reading Codes

### Tips

Follow these recommendations to improve codes readings.

- Code must be entirely visible in the field of view of the Wrist Camera.
- However, code should not fill the field of view entirely. Some whitespace must be left around its edges. Moving the Wrist Camera away from the code should increase its field of view and provide an adequate amount of whitespace.
- Background must contrast the code to read.

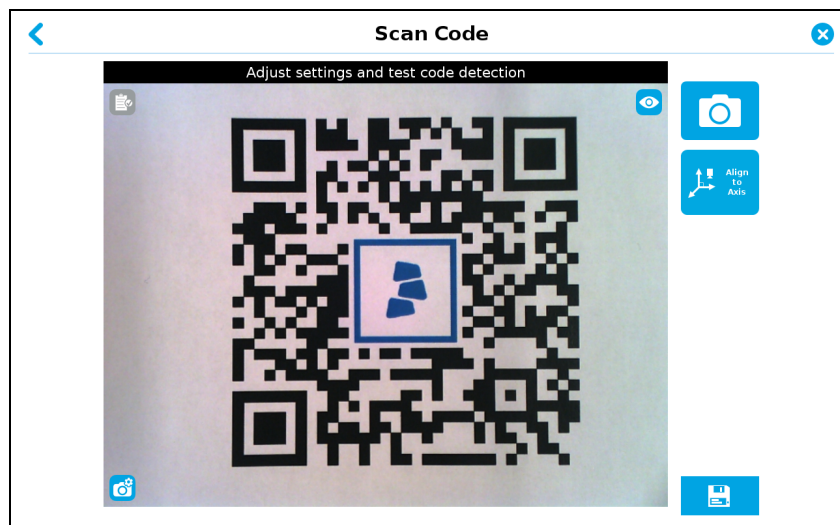



Fig. 9-1: This code cannot be read because there is not enough whitespace around its edges.



## 9.3. Using the Scan Code Node



1. Tap Program > URCaps > Scan Code.

2. Tap .

3. The window "Select Code Type" is displayed. Tap the applicable code type. To navigate pages for additional code types, use  and .

4. Put code on workplane, then tap , or retry by tapping  if you are not satisfied with the result. Save your code by tapping .

### Tip

You can tap  to display the string that was read from the code. This is useful when testing if your codes are read properly under your specific operating conditions.

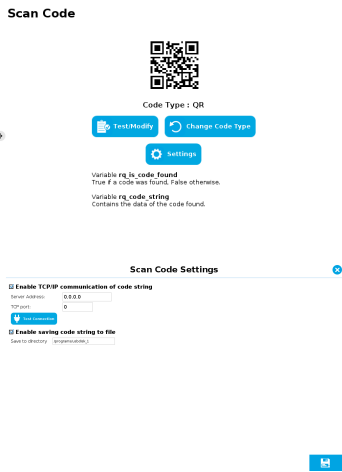

5. To save your readings, tap . The "Scan Code Settings" window is displayed.

6. To save collected strings to a file, check either box, or both. If you choose to save your data locally, you can use a USB stick to do so. The data will be stored in a .CSV file.

You can also use the string value during a program. Its value is stored in variable `rq_code_string`, found in the Variables tab.

## 9.4. Strings Data Stored in CSV files

	A	B	C	D	E	F
1	TimeStamp, CodeType, CodeData					
2	2019-11-01T15:53:22.892892,	QRCODE,	https://robotiq.com/			
3	2019-11-01T15:53:29.949949,	QRCODE,	https://robotiq.com/			
4	2019-11-01T15:53:37.03030,	QRCODE,	https://robotiq.com/			
5	2019-11-01T15:53:44.07474,	QRCODE,	https://robotiq.com/			
6	2019-11-01T15:53:51.09999,	QRCODE,	https://robotiq.com/			
7	2019-11-01T15:53:58.226226,	QRCODE,	https://robotiq.com/			
8	2019-11-01T15:54:05.229229,	QRCODE,	https://robotiq.com/			
9						
10						
11						
12						

Fig. 9-2: Each line represents one code that was read.

Data is presented in the following order: TimeStamp, CodeType, CodeData. Data elements are separated by commas.



Data Element	Description
TimeStamp	Records the year, month, date, hour, minutes, seconds, and seconds decimals at which the code was read.
CodeType	Records which type of code was read.
CodeData	Records a string read from a code.







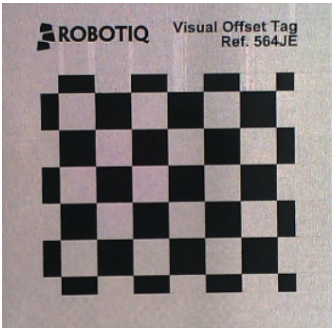
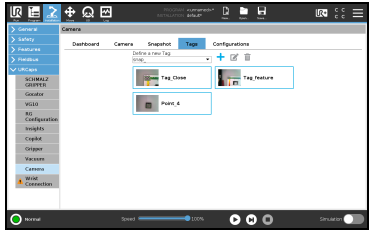

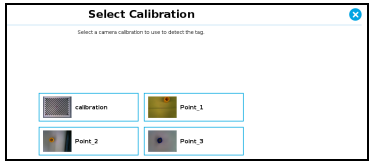
# 10. Find Visual Offset and Apply Visual Offset Nodes, and Defining Tags

The Wrist Camera Visual Offset capabilities are based on two nodes: Find Visual Offset and Apply Visual Offset. By attaching a Robotiq tag to a fixture (a tray, for instance), you can teach robot moves which are relative to this tag position. In other words, you can first teach the tag position, then teach moves, and even if your tray was moved, your robot program will compensate its move commands, first by finding out by how much the tray was displaced (using the node Find Visual Offset). This value is stored, then applied to moves under the node Apply Visual Offset subprogram.

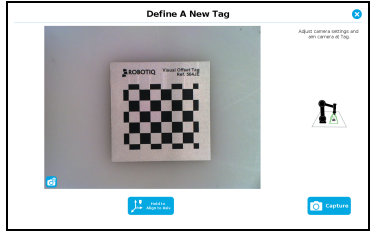
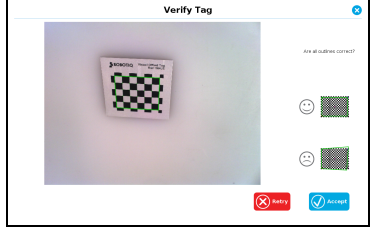
## 10.1. Defining a Tag

	<ol style="list-style-type: none"><li>1. Attach a tag to any surface. It is a reference feature for your robot program. The back of the tag has adhesive bands to help attach it.</li></ol>
	<ol style="list-style-type: none"><li>2. Move your robot to a position from which the Wrist Camera can fully see the tag, then create a feature Point at this location.</li><li>3. If you have not calibrated the Wrist Camera to your workplane, please do so now.</li></ol>
	<ol style="list-style-type: none"><li>3. Go to Installation &gt; URCaps &gt; Camera &gt; Tags.</li><li>4. From the dropdown list, select the feature Point you previously created, then tap .</li></ol>
	<ol style="list-style-type: none"><li>5. The "Select Calibration" window is displayed. Select the camera calibration to use to detect the tag.</li></ol>



	<p>6. The "Define A New Tag" window is displayed. You can tap capture to use default settings and try to read the tag right away.</p>
	<p>7. The "Verify Tag" windows is displayed. The half-squares must be outside of the green-bordered area shown on your tag. All fully formed squares must be inside the green-bordered area. If these two conditions are met, tap . Otherwise, tap . You will go back to the "Define A New Tag" window.</p> <p>Tap , then adjust parameters from the "Configure Camera" window in the following ways to enhance tag definition.</p> <ul style="list-style-type: none"> <li>• Turn off LED lighting.</li> <li>• Increase Exposure Sensitivity to 5-6EV.</li> <li>• Manually focus your Wrist Camera to obtain a crisp tag image.</li> <li>• To know exactly what your Wrist Camera sees, toggle the vision mode (default mode is  to . This should make the tag squares stand out. If they are blurry or incomplete, adjust the Wrist Camera parameters until their shapes are all fully displayed on the Teach Pendant.</li> </ul> <ul style="list-style-type: none"> <li>• When you are satisfied with the image onscreen, tap . Proceed as previously instructed to define your tag.</li> </ul>

## 10.2. Using a Tag in a Robot Program

Once a tag has been defined, you can start creating your robot program. The tag can serve as a reference point for moves in your program. Even if the tag moves (i.e. it is "offset"), the Wrist Camera can find its new location (see section **Find Visual Offset and Apply Visual Offset Nodes, and Defining Tags**), and quickly adjust your moves based on the value of the offset (see section **Find Visual Offset and Apply Visual Offset Nodes, and Defining Tags**).

Here is an example of a robot program using a tag and the nodes Find Visual Offset and Apply Visual Offset.

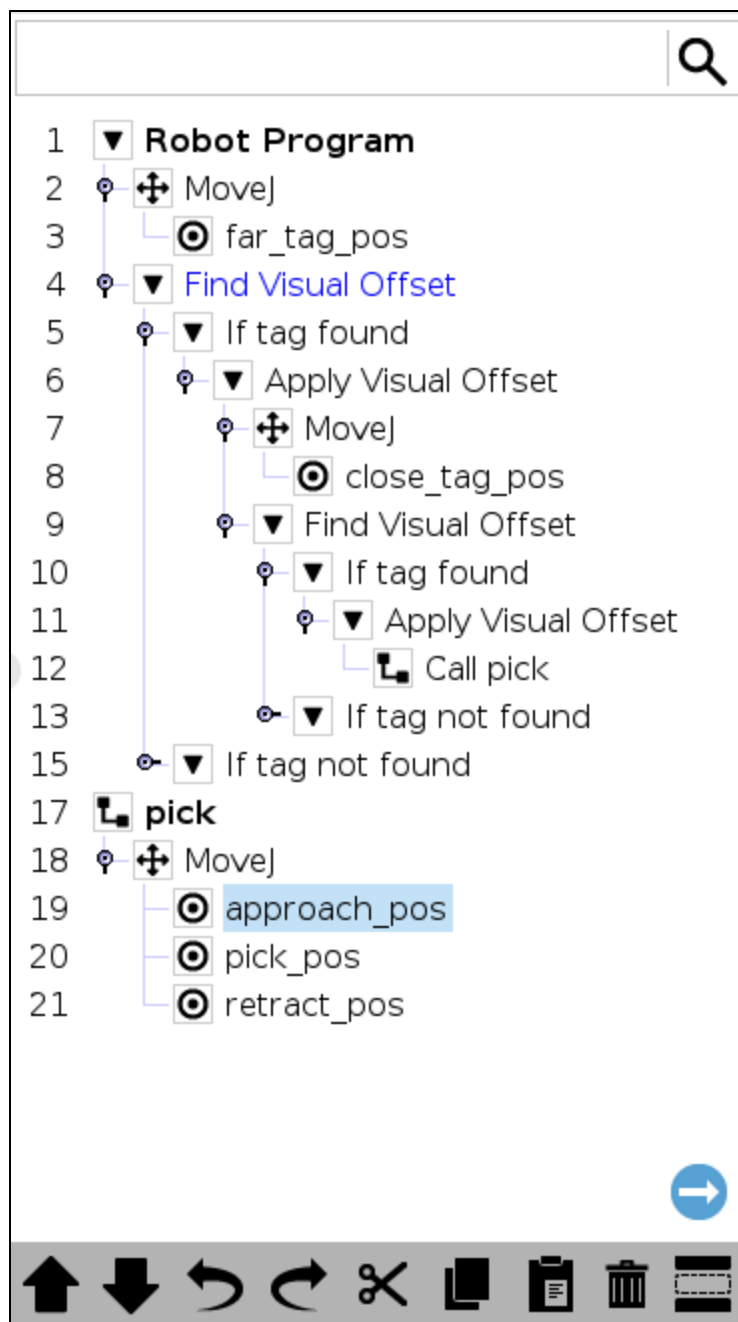

Fig. 10-1: This robot program detects a tag, then uses the nodes *Find Visual Offset* and *Apply Visual Offset* .







## 10.3. Find Visual Offset Node

This node is used to calculate by how much a tag was moved, in reference to its value as calibrated previously. The value of the offset found by this Find Visual Offset node is temporarily saved, and you can reapply it in a Apply Visual Offset node. In the program shown in **Fig. 10-1**, the condition "If tag found" is under the Find Visual Offset node. If no tag is found, no visual offset is applied to the robot program. If a tag is found, a visual offset is applied, and the robot moves to take a closer picture ("close\_tag\_pos"). A Find Visual Offset node is run again at a close distance (recommended distance is 15 cm max). Then, the value of the offset found at this step is used by an Apply Visual Offset node, which applies it to the "Call pick" routine (see lines 17-21 in the robot program shown in **Fig. 10-1**).

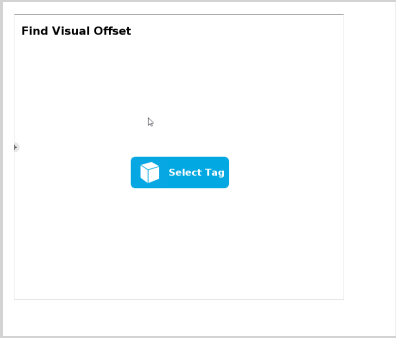

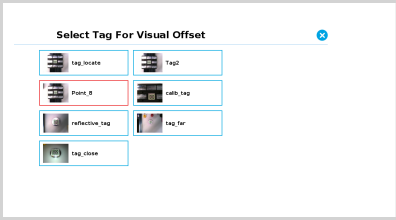
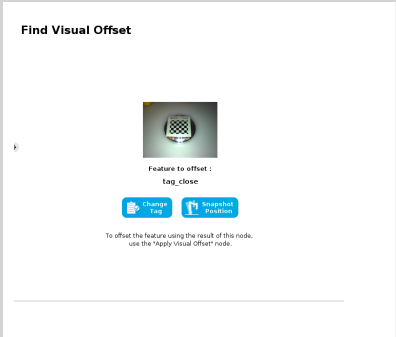
Here is how to use the Find Visual Offset node.

	<ol style="list-style-type: none"><li>1. Select the node Find Visual Offset from the left navigation pane.</li><li>2. Tap .</li></ol>
	<ol style="list-style-type: none"><li>3. The "Select Tag For Visual Offset" window is displayed. Tap the tag you wish to use for your Find Visual Offset node.</li></ol>
	<ol style="list-style-type: none"><li>4. A tag is selected for the Find Visual Offset node.</li></ol>

## 10.4. Apply Visual Offset Node

The Apply Visual Offset takes the value by which a tag has been offset, and modifies robot moves that are under this Apply Visual Offset node in the program. As a best practice, this node should be preceded by the condition "If tag found". Otherwise, if no tag is found with the Find Visual Offset node, the Apply Visual Offset may use a value found at a different time, which may not reflect the current offset value.

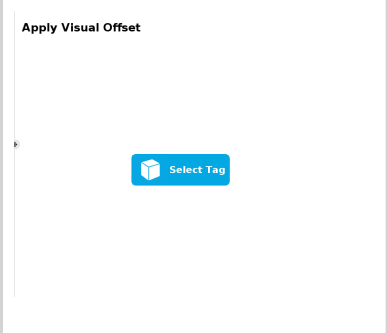
Here is how to use the Apply Visual Offset node.

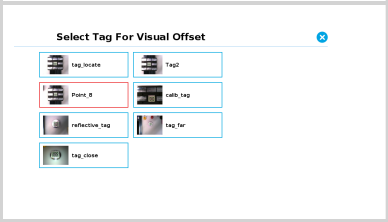
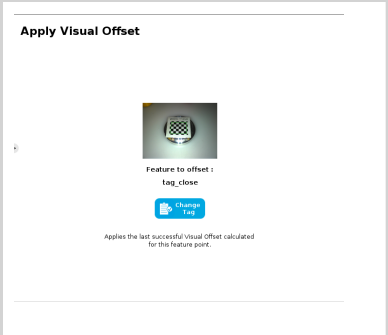
	<ol style="list-style-type: none"><li>1. Select the node Apply Visual Offset from the left navigation pane.</li><li>2. Tap .</li></ol>
	<ol style="list-style-type: none"><li>3. The "Select Tag For Visual Offset" window is displayed. Tap the tag you wish to use for your Apply Visual Offset node.</li></ol>
	<ol style="list-style-type: none"><li>4. A tag is selected for the Apply Visual Offset node.</li></ol>

After inserting this node into your robot program, create the rest of your program under the Apply Visual Offset node. All robot moves will be adjusted based on the value injected by this node.



# 11. Save Image Node

You can take pictures with the Wrist Camera in the course of a robot program, and save them to a USB stick. This node is complementary to the Wrist Camera URCap nodes.

Since saving an image can take up to five seconds for high-definition images, this node might slow down your cycle time. We recommend using the Save Image node under "if\_not\_found" conditions. The picture taken can then be used either as an alternative means to collect data (e.g. for barcodes that could not be read or when no object is detected using a Cam Locate node), or as a quality assurance tool to document difficulties, and improve your process in the future. Those uses are but suggestions. Use the Save Image node as it best suits your needs.

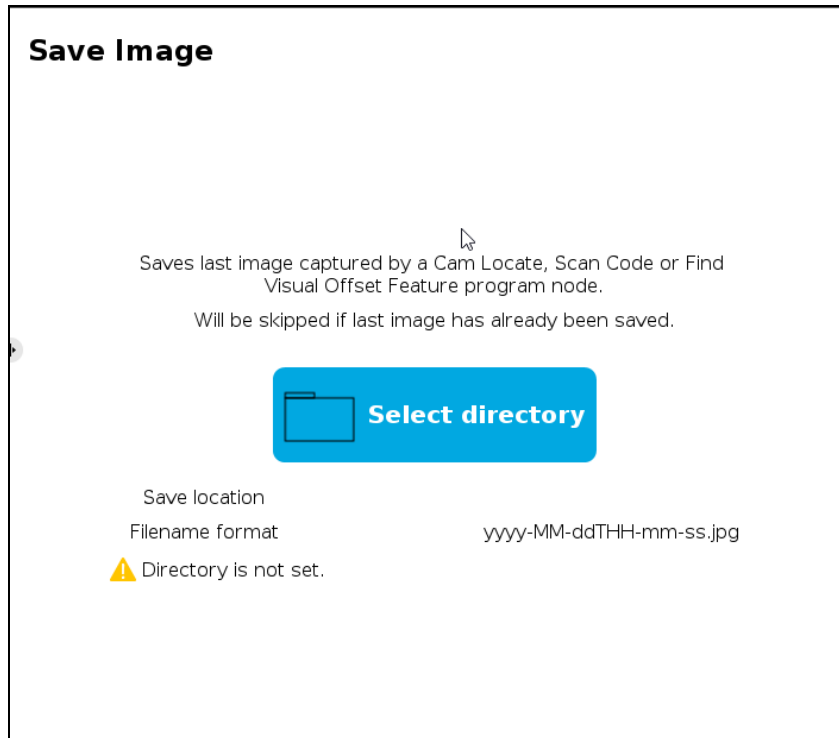

Fig. 11-1: The Save Image node.

To save images to a USB stick, tap .

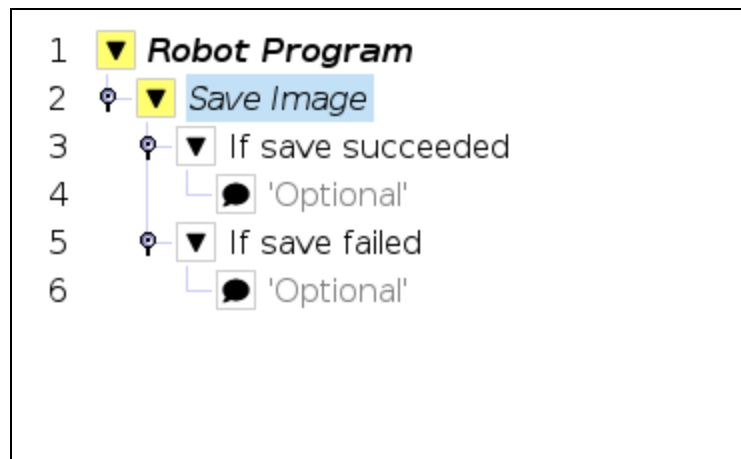

Fig. 11-2: The Save Image node in a robot program.



You can add different instructions following the Save Image node, based on its success or failure. Before adding those instructions, you will need to select the directory where images are saved.

Each image is saved in a separate .jpg file, and named as per this format: `yyyy-MM-ddtHH-mm-ss.jpg`.



---

# 12. Specifications

---

## Info

This manual uses the metric system. Unless otherwise specified, **all dimensions are in millimeters.**

This section contains specifications for the Robotiq Wrist Camera.

- section **Mechanical Specifications of Wrist Camera** on page **119**
  - Dimensions
  - Maximum load
  - Center of mass
  - Moment of inertia
- section **Electrical and Optical Specifications of the Wrist Camera** on page **121**
  - Electrical supply
  - Resolution
  - FPS
- section **Vision System Specifications** on page **122**
  - Field of view
  - Part size



## 12.1 Mechanical Specifications of Wrist Camera

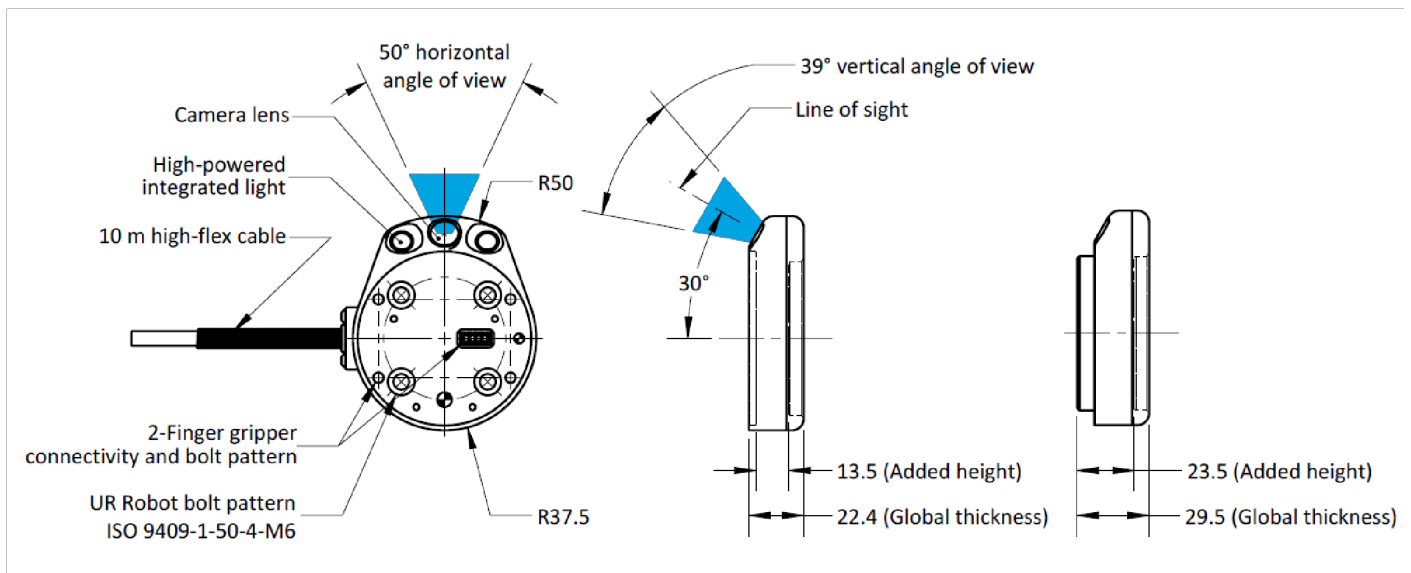

Fig. 12-1: Dimensions of the Wrist Camera.

Specification	Value	
Maximum load	10 kg	40 Nm
Weight (no tool plate)	160 g	
Weight (with tool plate)	230 g	
Added height (no tool plate, with a 2-Finger Adaptive Robot Gripper)	135 mm	
Global thickness (no tool plate)	224 mm	
Added height (with tool plate)	235 mm	
Global thickness (with tool plate)	295 mm	

Table 12-1: Mechanical Specifications of the Wrist Camera.

### Info

The photographic sensor, in line with Universal Robots axes system, is located at [0mm, 35.7mm, 0.1mm] of the tool flange on which the Wrist Camera is mounted. The line of sight passes through this point at 30° from the Z-axis.

### 12.1.1 Center of Mass and Moment of Inertia

The coordinate system used to calculate the moment of inertia and center of mass of the Wrist Camera is the base of the Wrist Camera, which correspond to the Universal Robots tool flange reference [0,0,0].



Here is the approximate position for the center of mass. It has been calculated for the Wrist Camera itself and for combinations with other Robotiq products. The tool plate is included when no gripper is mounted on the Wrist Camera.

Combination	x (mm)	y (mm)	z (mm)	Mass (grams)
-	0	5	9	230
FT 300	0	2	30	530
2-Finger 85	0	1	58	975
2-Finger 140	0	1	66	1040
FT 300 and 2-Finger 85 (CB-Series models)	0	1	77	1275
FT 300 and 2-Finger 140 (CB-Series models)	0	1	85	1340

Table 12-2: Tool center point coordinates and payloads for some combinations of Robotiq hardware with the Wrist Camera.

Inertia Matrix			Metric value (kg * mm <sup>2</sup> )			Imperial value (lb * in <sup>2</sup> )		
lxx	lxy	lxz	111	0	0	0.38	0	0
lyx	lyy	lyz	0	70	3	0	0.24	0.01
lzx	lzy	lzz	0	3	165	0	0.01	0.56

Table 12-3: Moment of inertia matrix for the Wrist Camera. Values are approximated.



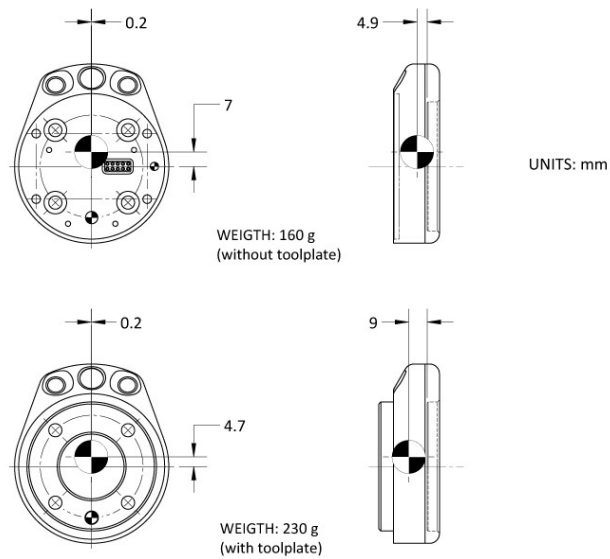

Fig. 12-2: The Wrist Camera center of mass, without and with tool plate.

## 12.2. Electrical and Optical Specifications of the Wrist Camera

Robotic User Interface recommends you supply power to the Wrist Camera from the Universal Robots robot controller, as shown in section **Electrical Setup**; if for any reasons you cannot do so, here are the electrical specifications of the Wrist Camera.

Specification	Value
Operating supply voltage	24 V DC ±20%
Quiescent power (minimum power consumption)	1 W
Maximum power	22 W
Communication interface	USB 2.0

Table 12-4: Wrist Camera electrical specifications.

Specification	Value
Maximum resolution	5 Mpx at 2 fps (2560 X 1920)
Maximum frame rate	30 fps at 0.3 Mpx (640 X 480)
Active array size	2592 X 1944



Specification	Value
Focus range	70 mm to $\infty$
Integrated lighting	6 LED diffuse white light
Autofocus technology	Liquid lens

Table 12-5: Wrist Camera optical specifications.

## 12.3. Vision System Specifications

### 12.3.1 Accuracy

The accuracy of the vision system is as described in the table below and depends on the robot model used. It is valid for the area where the calibration board was located during the calibration process.

Robot Model	Accuracy
UR3	+/- 2mm
UR5	+/- 3mm
UR10	+/- 3mm

Fig. 12-3: Accuracy of the vision system.



### 12.3.2. Calibration Board Position

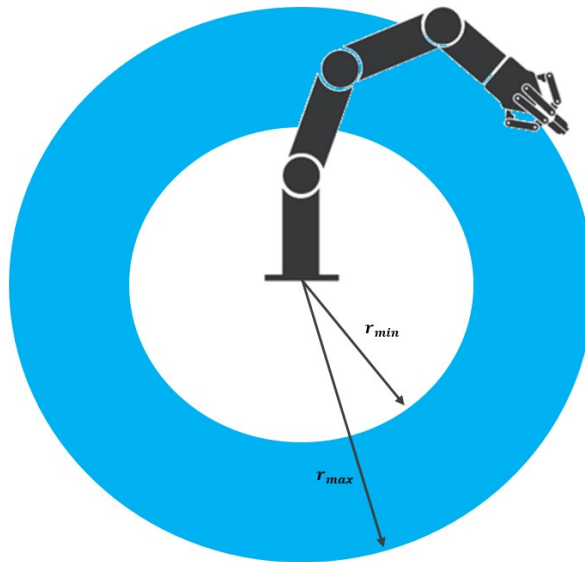

Fig. 12-4: Calibration board position.

Specification	Value		
	UR 3	UR 5	UR10
Minimum board distance (cm)	26	34	42
Maximum board distance (cm)	42	70	98

#### Tips

The snapshot position determines the field of view. Notice that the calibration position can differ from the snapshot position. You can have a small field of view, then move back to get a wider field of view for calibrating.

### 12.3.3. Field of view

The field of view of the Wrist Camera varies based on the distance between the work plane and the Wrist Camera. The table below shows fields of view for some Universal Robots models.

	UR3		UR5		UR10	
	Distance* (mm)	FoV (mm)	Distance* (mm)	FoV (mm)	Distance* (mm)	FoV (mm)
Maximum**	347	360 x 270	646	640 x 480	1030	1000 x 750
Minimum**	70	100 x 75	70	100 x 75	70	100x 75

Table 12-6: The field of view of the Wrist Camera varies based on robot reach.

\*Workplane surface to camera distance (considering the workplace surface at the same level as the robot base).

\*\*For indication only, larger field of view is possible depending on robot mounting configuration and parts locations. Contact Robotiq support if more information is required.

**Info**

Field of view is (FoV) determined by snapshot position. To get the minimum FoV, the Wrist Camera must be 7 cm above its work plane.

### 12.3.4. Part dimensions

The maximum part size that can be detected by the Wrist Camera is 60% of the field of view. The minimum is 10%, no matter the robot or the field of view size.

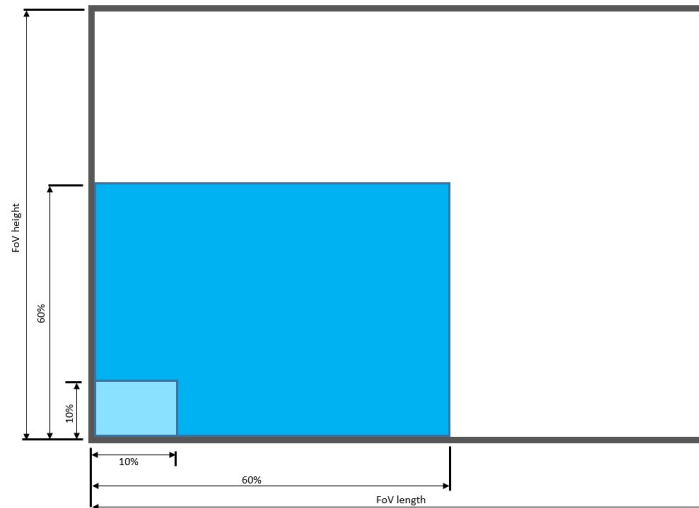
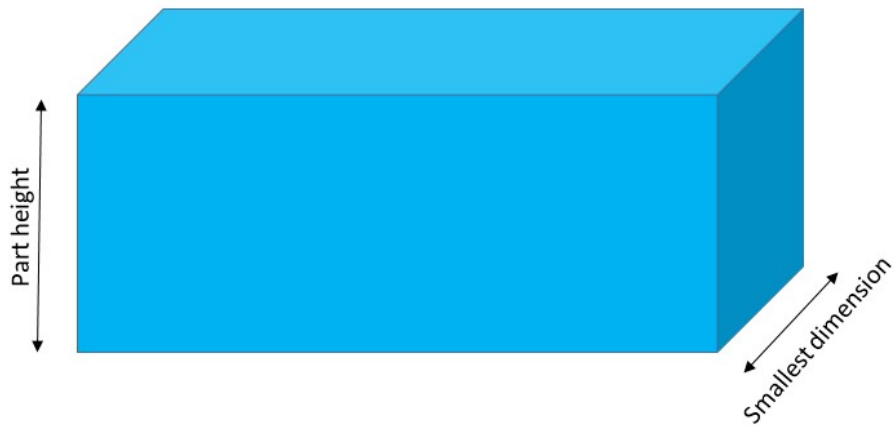

Fig. 12-5: Maximum and minimum part size.

The part must not be higher than its smallest dimension (width or length) : maximum of 1:1 ratio.





*Fig. 12-6: Maximum part height.*

**Info**

Part height ratio is taken between the maximum part height at any point and the minimum dimension present on part contour, width or length.

## 12.3.5. Background contrast

To ensure a good model and part detection from the Vision system, you should use a background that has a high color contrast with the part to be detected. You must choose colors that are apart horizontally on the HSV cone shown below. Therefore, a change in value (intensity) only does not represent a good contrast. There has to be a great difference in hue and saturation to obtain a good object model from the object teaching wizard. You can use either the yellow or pink side of the colored background provided with the camera kit. If required, use a different colored background to teach your part.



---

## 13. Maintenance of the Wrist Camera

---

The Wrist Camera requires no maintenance. Make sure its lens remains free from liquid or dust. To clean the lens, apply alcohol and wipe it with the pouch that contained your Wrist Camera.

The work plane should remain unchanged through time. Depending on your application, you should occasionally clean the work plane more or less regularly.

### Caution

If you change your work plane background after the teaching process, this could lead to a decrease in object detection.

### Tip

The Vision System can compensate for some differences during runtime. Adjust the detection threshold as explained in the section **Detection thresholds and scores** on page 83 to have a reliable object localization.



## 14. Spare Parts, Kits and Accessories

The following list is up-to-date at print time and is subject to change. Check online for updates.

### Info

Unless specified, screws, dowel pins and other hardware are included only for the Sensor side, never for the robot side.

Item	Ordering Number
Wrist Camera Kit for Universal Robots. Includes Wrist Camera, calibration board, tool plate for UR, USB memory stick, license and hub and all hardware.	RWC-UR-KIT
Replacement Wrist Camera. Includes 10 m pigtail cable.	RWC-CAM-001
Wrist Camera tool plate for ISO 9409-1-50-4M6 pattern (Universal Robots).	RWC-TOOL-062
Replacement calibration board.	ACC-CALIB-BOARD
Replacement 10m High-Flex pigtail cable for Wrist Camera.	CBL-COM-2069-10-HF
4-port USB 2.0 hub splitter	ACC-USB-4-HUB
16 Gb USB stick	ACC-USB-16G
Replacement software license USB dongle for Wrist Camera	ACC-USB-DONGLE
Universal Robots Screw Kit for Wrist Camera	ACC-SCREW-KIT-RWC-UR
Wrist Camera Tag for Visual Offset (5 bags of 5) (partners only)	ACC-TAG-5BAG5
Wrist Camera Tag for Visual Offset (5)	ACC-TAG-1BAG5



# 15. Troubleshooting

## Info

For details on the Vision server, Camera URCap and Wrist Camera firmware versions, go to the Installation tab > Camera > About.

Versions are displayed. Check version numbers, and update all URCap to their latest release.

LED colors can provide information on the issue you are facing. Read the table below for more details.

LED status	Description	Solutions
Off	The Camera is not powered.	Check the Camera's power supply and electrical setup (please refer to the <b>Electrical Setup</b> ).
Solid red	No fault but the Camera is not communicating.	<p>Start or do a stop/start cycle of the Vision server.</p> <p>To do so, go in the Installation tab, choose Camera and then the Camera tab.</p> <p>Click on <b>Start camera</b> to start the Vision server.</p> <p>The output image will appear and the LED will turn blue.</p> <p>Check the USB cable connection and the software package versions.</p>
Solid blue and red at the same time	The Camera is in fault or booting.	<p>Wait for the booting process to be completed.</p> <p>If the LED stays solid blue and red, disconnect the Camera's USB cable and power cycle it.</p> <p>The red LED should be solid red. Reconnect the USB cable.</p> <p>The LED should turn solid blue when communication is established with the Vision server (click on <b>Start camera</b> from the Installation tab).</p>
Blinking blue and red	Major fault: <ul style="list-style-type: none"><li>• Camera's input voltage is not sufficient</li><li>• Temperature is greater than 70°C</li></ul>	<ul style="list-style-type: none"><li>• Check the power supply to make sure it is 24 V DC +/- 10%.</li><li>• The Wrist Camera should not operate at a temperature higher than 50°C.</li></ul>
Solid blue	Not fault and communicating.	-





---

## 16. Wrist Camera Warranty and Patent

---

Robotiq warrants the Wrist Camera and Vision System against defects in material and workmanship for a period of one year from the date of reception when utilized as intended. Robotiq also warrants that this equipment will meet applicable specifications under normal use.

Warranty applies under the following conditions:

- Usage respects the operating and storage conditions specified in the **Environmental and Operating Conditions**.
- Proper installation of the Wrist Camera specified in the **Installation** and the following subsections.
- Usage under normal one-shift operation (40 h a week)
- Usage respects maintenance specified in the **Maintenance of the Wrist Camera**.
- Usage respects recommended payload and forces specified in the **Mechanical Specifications of Wrist Camera**.

During the warranty period, Robotiq will repair or replace any defective Wrist Camera, as well as verify and adjust the Camera free of charge if the equipment should need to be repaired or if the original adjustment is erroneous. If the equipment is sent back for verification during the warranty period and found to meet all published specifications, Robotiq will charge standard verification fees.

The unit is considered defective when at least one of the following conditions occurs :

- The Camera does not output any image;
- The Camera feedback necessary for the robot program is not accessible;
- The Vision System USB memory, USB hub or USB dongle are inoperable;

### Caution

The warranty will become null and void if the :

- Unit has been tampered with, repaired or worked on by unauthorized individuals.
- Warranty sticker has been removed.
- Screws, other than as explained in this guide, have been removed.
- Unit has been opened.
- Unit serial number has been altered, erased, or removed.
- Unit has been misused, neglected, or damaged by accident.

This warranty is in lieu of all other warranties expressed, implied, or statutory, including, but not limited to, the implied warranties of merchantability and fitness for a particular purpose. In no event shall Robotiq be liable for special, incidental, or consequential damages.

Robotiq shall not be liable for damages resulting from the use of the Robotiq Wrist Camera or Robotiq Vision System, nor shall Robotiq be responsible for any failure in the performance of other items to which the Wrist Camera is connected or the operation of any system of which the Vision System may be a part.

### Exclusions

This warranty excludes failure resulting from: improper use or installation, normal wear and tear, accident, abuse, neglect, fire, water, lightning or other acts of nature, causes external to the Wrist Camera, the Vision System or other factors beyond Robotiq's control.



Robotiq reserves the right to make changes in the design or construction of any of its products at any time without incurring any obligation to make any changes whatsoever on units already purchased.



---

# 17. Wrist Camera Harmonized Standards, Declarations and Certificates

---

## 17.1. Declaration of Incorporation



### Translation of Original Declaration of Incorporation

In terms of the Directive 2006/42/EC, Annex II, part B of the European Parliament and of the Council on machinery, we, the manufacturer,

Robotiq Inc.  
966, Chemin Olivier, suite 325  
Lévis, Québec, Canada, G7A 2N1

hereby declare that the following product:

#### Robotiq Vision System

meets the applicable requirements of the **Machinery Directive 2006/42/EC** of the European Parliament and of the Council. The incomplete machine may not be operated until the machine in which it is integrated is declared compliant with the relevant provisions of the 2006/42/CE Machinery Directive.

The manufacturer agrees to forward, upon request of national competent authorities, the relevant technical documents specified by Annex VII, part B, within the prescribed time.

Additionally, the product declares in conformity with the following directives, according to which the product is CE marked:

2014/30/EU	Electromagnetic Compatibility Directive (EMC)
2011/65/EU	Restriction of the use of certain hazardous substances (RoHS)

Person responsible for documentation: Annick Mottard, Jr. Eng., address: see manufacturer address

Lévis, November 2017

A handwritten signature in black ink, appearing to read 'JP Jobin'.

Jean-Philippe Jobin  
Vice President Research and Development

Robotiq Inc.

The following standards have been applied:

NF EN ISO 12100	2010	Safety of machinery — General principles for design — Risk assessment and risk reduction
CEI 60204-1 Ed.6.0	2016	Safety of machinery — Electrical equipment of machines — Part 1: General requirements



## 17.2. Ingress Protection Certificate



October 12<sup>th</sup> 2018

### **Purpose: Ingress Protection (IP67) – Wrist Camera Test Certificate**

To whom it may concern,

This certificate is to attest that Ingress Protection (IP) tests were carried out by NTS Canada in the months of June and July 2018 on Wrist Cameras manufactured by Robotiq. No ingress of dust or water was observed inside the units after the tests. No insertion of the rod or induced damage was observed. No functional anomaly was noticed or reported by the Robotiq engineering representative on-site during the tests. This test certificate does not supersede the test report FTR0201898 Rev 00 issued by NTS Canada.

The acceptance status for the units tested is "PASS" for the following tests;

- Ingress protection against access to hazardous parts – Rod (code IP6X)
- Ingress protection against solid foreign objects - Dust (code IP6X)
- Ingress protection against immersion in water (code IPX7)

Sincerely yours,

**Jean-Pierre  
Rioux**

Digitally signed by Jean-Pierre  
Rioux  
DN: cn=Jean-Pierre Rioux, o,  
ou=NTS Canada Inc.,  
email=Jean-  
Pierre.Rioux@NTS.com, c=CA  
Date: 2018.10.12 11:32:13  
-0400'

---

Jean-Pierre Rioux, P. Eng.  
Lab Manager  
National Technical Systems Canada inc.  
2425 Industrial Blvd  
Chambly, Quebec  
J3L 4W3 Canada



---

# 18. Contact

---

[www.robotiq.com](http://www.robotiq.com)

## Contact Us

### Phone

1-888-ROBOTIQ (762-6847)  
(+1) 418-380-2788 Outside US and Canada

### Fax

1-418-800-0046

### Technical Support and Engineering

extension 3

### Sales

extension 2

### Head office

Robotiq:  
966, chemin Olivier  
Suite 500  
Lévis, Québec  
G7A 2N1  
Canada



Where automation Pros come to share their know-how and get answers.

[dof.robotiq.com](http://dof.robotiq.com)

